

Devices Connected/Referenced

AD9834	75 MHz Complete Low Power DDS
AD8014	400 MHz Low Power High Performance Amplifier

Low Power DDS Waveform Generator

EVALUATION AND DESIGN SUPPORT

Circuit Evaluation Boards

[CN0304 Evaluation Board \(EVAL-CN0304-SDZ\)](#)

[SDP-B Evaluation Board \(EVAL-SDP-CB1Z\)](#)

Design and Integration Files

[Schematics](#), [Layout Files](#), [Bill of Materials](#)

CIRCUIT FUNCTION AND BENEFITS

The circuit shown in Figure 1 is a 75 MHz low power (25 mW total) direct digital synthesis (DDS) waveform generator. The output buffer and anti-imaging filter provide improved spectral performance, making it suitable for frequency generation or

clocking applications requiring sine wave, triangular wave, and square outputs up to 18 MHz.

Because they are sampled data devices, low power DDS devices must be followed by a suitable anti-imaging filter to remove spectral images. However, the maximum current output is approximately 4 mA into a recommended 200 Ω load; therefore, an optimum low power, low distortion op amp buffer at the DDS output provides a low impedance drive source for a high quality 50 Ω filter.

The combination of the DDS, output buffer, and seventh-order elliptic low pass filter provides high quality spectral performance.

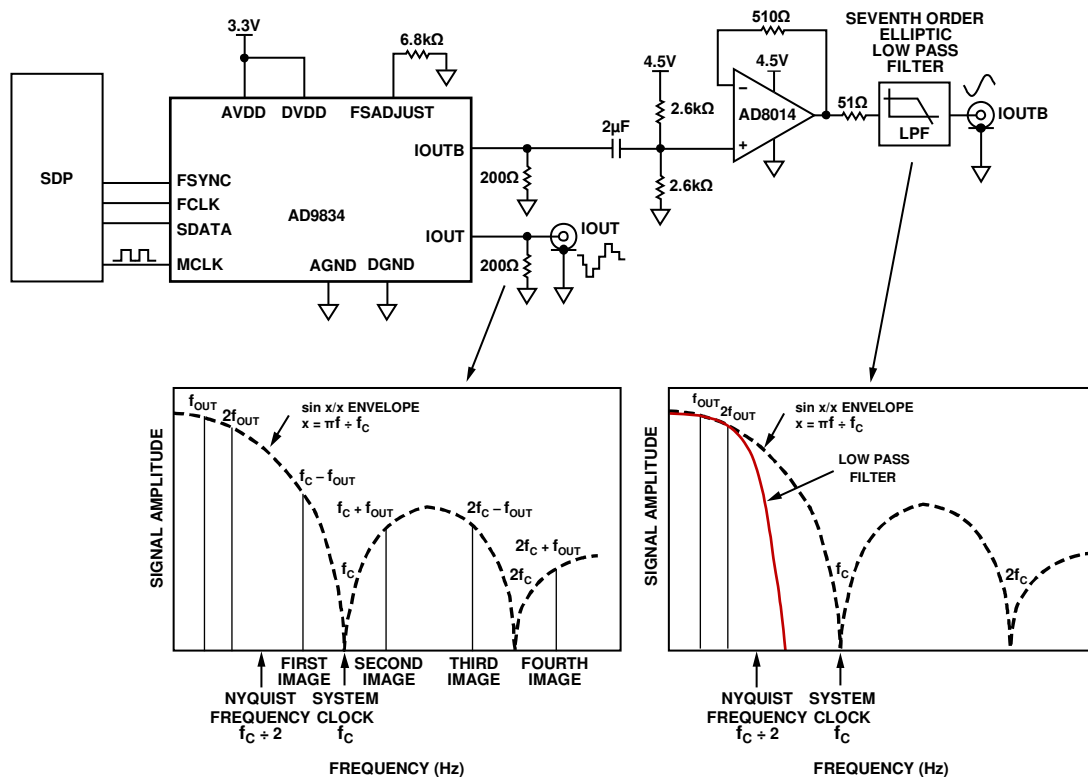

Figure 1. Low Power Waveform Generator (Simplified Schematic: All Connections and Decoupling Not Shown)

12064-001

Rev. 0

Circuits from the Lab[®] reference designs from Analog Devices have been designed and built by Analog Devices engineers. Standard engineering practices have been employed in the design and construction of each circuit, and their function and performance have been tested and verified in a lab environment at room temperature. However, you are solely responsible for testing the circuit and determining its suitability and applicability for your use and application. Accordingly, in no event shall Analog Devices be liable for direct, indirect, special, incidental, consequential or punitive damages due to any cause whatsoever connected to the use of any Circuits from the Lab circuits. (Continued on last page)

CIRCUIT DESCRIPTION

The **AD9834** is a 75 MHz complete low power (20 mW) DDS. It is designed to provide true and complementary current outputs up to 4 mA with output frequencies up to 37.5 MHz.

The **AD8014** is a high speed current feedback amplifier with 400 MHz, -3 dB bandwidth, 4000 V/ μ s slew rate, and 24 ns settling time. It has extremely low voltage and current noise as well as low distortion. The low power (5.2 mW at +4.5 V), low cost, and 30 mA current drive capability make the **AD8014** an attractive solution as a buffer for the **AD9834** output. The circuit operates on +3.3 V for the **AD9834** and +4.5 V for **AD8014**. The DDS operates with an SPI interface. The circuit consists of three blocks: the DDS block, the buffer block, and the low-pass filter block. Total power dissipation for the circuit is about 25 mW.

DDS Voltage Output

The full-scale adjust (FSADJUST) voltage and the external resistor, R_{SET} , determine the magnitude of the full-scale DAC current. The FSADJUST has a nominal value of 1.15 V, while the R_{SET} resistor has a typical value of 6.8 k Ω .

The full-scale current of the **AD9834** is as follows:

$$I_{FULLSCALE} = 18 \times (\text{FSADJUST}/R_{SET})$$

This circuit uses a specified load of 200 Ω and maximum full-scale current to achieve voltage output without exceeding the compliance range of the DAC.

$$I_{FULLSCALE} = 18 \times (1.15/6800 \Omega) = 3 \text{ mA},$$

$$V_{OUT} = 3 \text{ mA} \times 200 \Omega = 0.6 \text{ V}$$

There are two current outputs available on the board: IOUT and IOUTB. The IOUT is unfiltered, and the IOUTB is filtered.

Buffer Amplifier

Due to the limited current and voltage compliance range at the output of the DDS, a buffer is necessary to provide higher current drive capability to the low-pass filter. In addition, the buffer provides isolation between the DDS block and the filter block and converts the 200 Ω output impedance of the loaded DDS to the 50 Ω required to drive the terminated filter. In this circuit note, the low-power high-performance current feedback operational amplifier **AD8014** is used as an output buffer of the **AD9834**. The **AD8014** is a high speed current feedback amplifier with 400 MHz, -3 dB bandwidth, 4000 V/ μ s slew rate and 24 ns settling time. It has an output current drive of ≥ 30 mA. The feedback resistor in the **AD8014** current feedback op amp sets the bandwidth of the op amp.

Figure 2 shows the feedback resistor of 510 Ω . Because the op amp is operating from a single polarity supply, the output needs to be centered on mid-supply to prevent clipping. The voltage divider at point A provides a 2.25 V dc offset to the sinusoidal signal that gives an output swing of $2.25 \text{ V} \pm 0.3 \text{ V}$. For correct biasing of op amps in single supply applications, refer to [Application Note AN-581, Biasing and Decoupling Op Amps in Single Supply Applications](#). For more information on current

feedback amplifiers, refer to the [MT-034 Tutorial, Current Feedback \(CFB\) Op Amps](#).

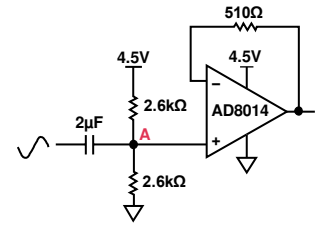

Figure 2. **AD8014** Input and Feedback Connections

Seventh-Order Elliptic Low Pass Filter

The anti-imaging reconstruction must attenuate the image frequencies inherent to a sampled system as shown in Figure 1.

There are four basic filter types that can be used as a reconstruction filter: Cauer (elliptic), Chebyshev, Butterworth, and Bessel. Figure 3 shows the response curves of these four basic filter types.

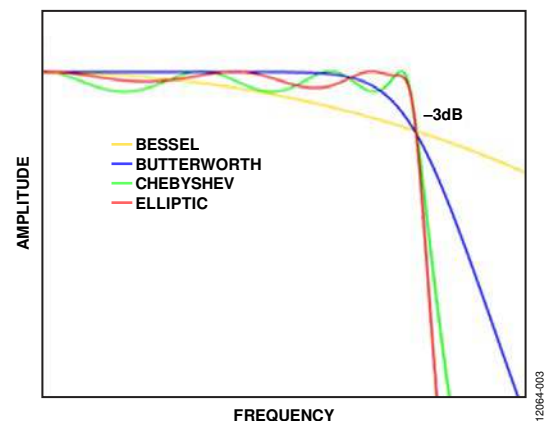

Figure 3. Response Curves for Four Basic Filter Types

For the same order, the elliptic filter has a higher roll-off rate compared to the other three, therefore, it makes an attractive candidate for the reconstruction filter. The filter used in this circuit note is a 7th order elliptic filter with a -3 dB bandwidth of 18 MHz.

Component Selection

The resistors, capacitors, and inductors used to implement the filter are passive components, and, due to the high frequencies involved, must meet the following requirements:

- Low parasitic capacitance and inductance.
- Low tolerance values so that the measured response is close to the design response.
- Wide temperature range.
- Small physical to minimize parasitic capacitance and inductance.

These are just a few of the criteria that ensure measured filter response is close to the simulated filter response.

For more information on selecting passive components for specific application, please refer to [Basic Linear Design: Chapter 10, Passive Components](#).

Filter Design and Performance

The 7th order elliptic filter is shown in Figure 4, and the simulated and actual frequency response of the filter is shown in Figure 5. The software used is Advances Design System (ADS) Version 2012.08. The actual filter components and manufacturers can be found in the bill-of-materials in the CN0304 Design Support Package at <http://www.analog.com/CN0304-DesignSupport>.

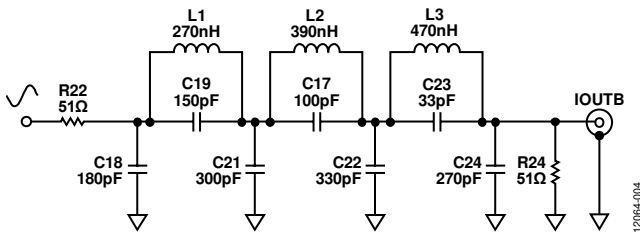

Figure 4. 7th order, Shunt-Connected Low Pass Filter

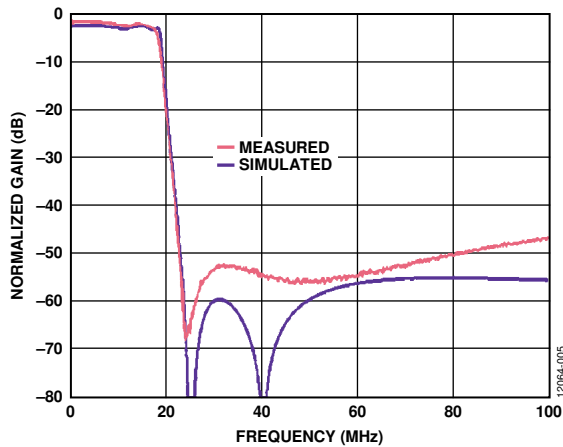

Figure 5. Simulated vs. Measured Frequency Response of the 7th-Order Elliptic Filter

The measured filter response was taken using the Agilent E5061B Network Analyzer. It shows the -3 dB bandwidth to be 18 MHz. The pass band attenuation is approximately 6 dB due to the source and load termination.

To check the performance of the circuit, the spectrum of the DDS output were measured with AD9834 set to an output frequency of 15 MHz with a 75 MSPS clock. The unfiltered and filtered outputs are shown in Figure 6 and Figure 7, respectively.

As shown in Figure 7, there is a significant reduction of the undesired images that appear in the unfiltered spectrum of Figure 6. The highest image spur at 60 MHz is suppressed by about 52 dB relative to the unfiltered output. This corresponds to the measured attenuation of the filter at 60 MHz.

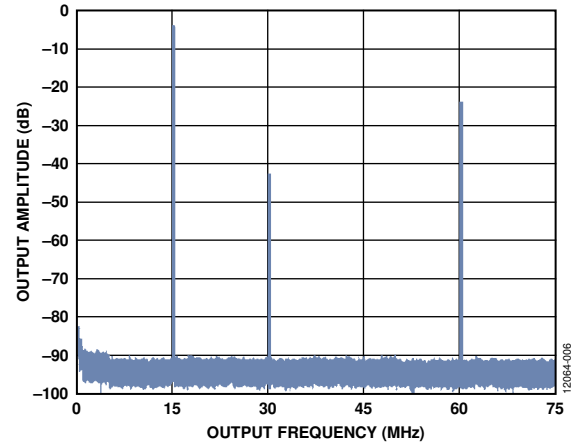

Figure 6. Unfiltered Output of AD9834 set to 15 MHz measured at IOUT

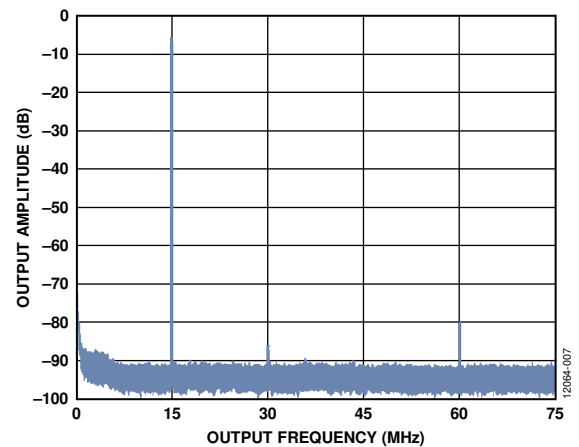

Figure 7. Filtered Output of AD9834 set to 15 MHz taken at IOUTB

The 600 mV p-p output of the AD9834 is attenuated by approximately 6 dB by the filter, and an additional 1 dB by the sin x/x roll off. The output into the 50 Ω load is therefore approximately 268 mV p-p, or 94.7 mV rms. This corresponds to 0.179 mW, or -7.5 dBm.

For more information on the reconstruction filter design for DDS, refer to [Application Note AN-837, DDS-Based Clock Jitter Performance vs. DAC Reconstruction Filter Performance](#).

The circuit must be constructed on a multilayer PC board with a large area ground plane. Proper layout, grounding, and decoupling techniques must be used to achieve optimum performance (see [MT-031 Tutorial, Grounding Data Converters and Solving the Mystery of “AGND” and “DGND,”](#) and [MT-101 Tutorial, Decoupling Techniques](#)).

Complete design support package including schematics, layouts, and bill of materials can be found at <http://www.analog.com/CN0304-DesignSupport>.

COMMON VARIATIONS

An alternative for the DDS is the [AD9838](#). It has lower power (11 mW) and offers the same functionality of the [AD9834](#) but with lower clock rate of 16 MHz.

The buffer used in this circuit note is the current-feedback amplifier [AD8014](#). An alternative for this is the [ADA4860-1](#). It is a low cost, high speed (800 MHz, -3 dB bandwidth), low power (22.5 mW at 5 V), current feedback operational amplifier, but with a lower slew rate of 790 V/ μ s.

A voltage-feedback (VFB) amplifier can also be used for the buffer. The advantage of a VFB amplifier is lower noise and more freedom in choosing feedback components. The [AD8057](#) is a voltage feedback amplifier with bandwidth and slew rate normally found in current feedback amplifiers. It has 325 MHz, -3 dB bandwidth, gain flatness of 0.1 dB to 28 MHz, and slew rate of 1000 V/ μ s.

Another alternative is the [ADA4897-1](#). It is a unity-gain stable, low wideband noise, rail-to-rail output high speed voltage feedback amplifier, with input voltage noise of 2.4 nV/ $\sqrt{\text{Hz}}$ at 10 Hz and a spurious free dynamic range (SFDR) of -80 dBc at 2 MHz.

The [ADA4851-1](#) can also be used as buffer. It is a low cost, low power, high-speed (-3 dB bandwidth of 130 MHz) device, but with much a lower slew rate of 375 V/ μ s.

CIRCUIT EVALUATION AND TEST

Equipment Required

- [EVAL-CN0304-SDZ](#) evaluation board
- [EVAL-SDP-CB1Z](#) evaluation board
- [AD9834 Evaluation Software](#)
- Agilent E3631A triple output dc power supply or equivalent
- Rohde and Schwarz FSUP50 Signal Source Analyzer
- Agilent E5061B Network Analyzer (needed only to evaluate the filter response)

Filter Response Measurement

The frequency response of the filter was measured with a network analyzer using the setup shown in Figure 8.

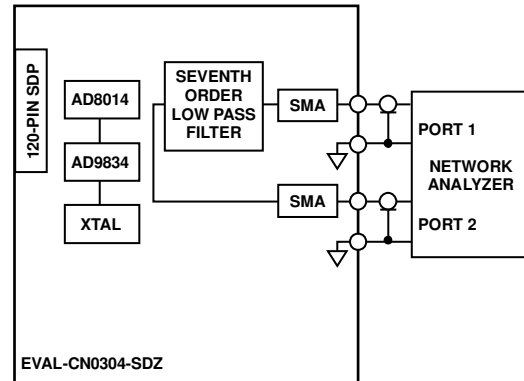

Figure 8. Test Setup for Measuring Filter Response

The [EVAL-CN0304-SDZ](#) board was modified, and the signal from the network analyzer applied to the input of the filter. The output of the filter was connected to the second port of the analyzer.

Output Waveform Measurement

The output waveform of the DDS was measured using the setup in Figure 9.

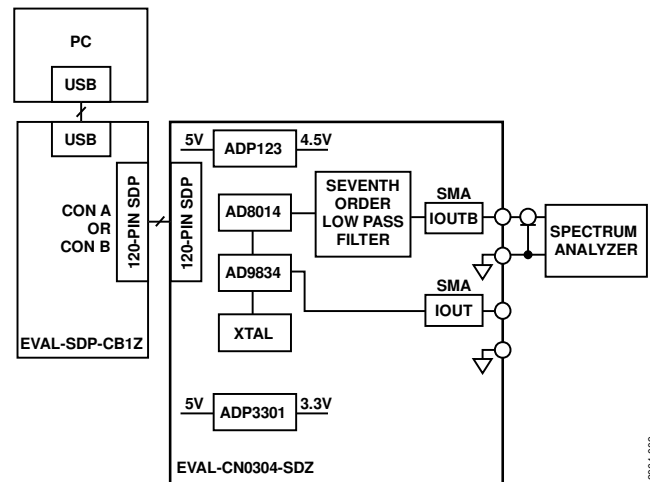

Figure 9. Test System Functional Diagram for DDS Output

The 5 V supply for the [EVAL-CN0304-SDZ](#) is derived from the 5 V USB voltage from the SDP card. Set the jumpers as follows: LK1 in B position, LK2 in B position, and LK3 removed.

The [AD9834 Evaluation Software](#), located at <ftp://ftp.analog.com/pub/evalcd/AD9834/>, was used to set the output frequency and amplitude of the DDS. See the [AD9834 Evaluation Board User Guide, UG-266](#) for further details. The hardware described in [UG-266](#) does not have the 7th order output filter; however, the graphical user interface and software operation is identical to the [EVAL-CN0304-SDZ](#) hardware.

A photograph of the [CN0304](#) printed circuit board is shown in Figure 10.

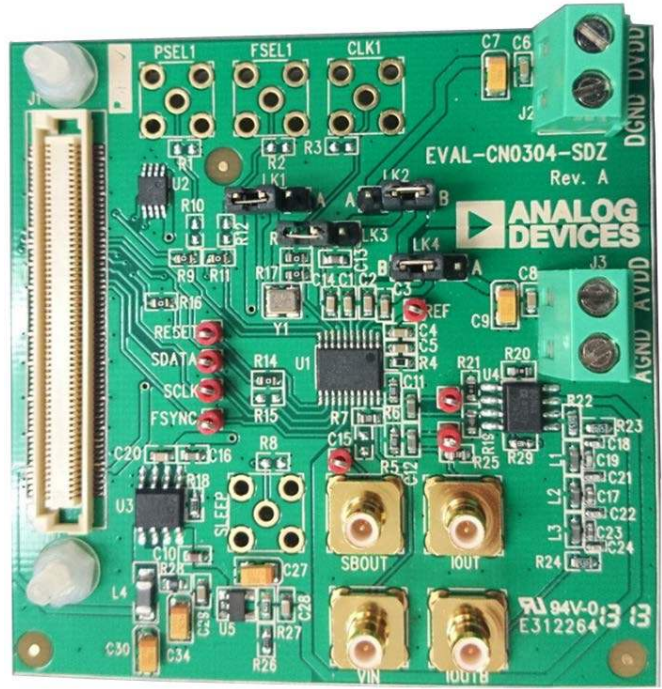

Figure 10. Photograph of the EVAL-CN0304-SDZ Board

LEARN MORE

CN0304 Design Support Package:

<http://www.analog.com/CN0304-DesignSupport>.

ADIsimDDS Design and Evaluation Tool.

UG-266 User Guide, *Evaluating the AD9834 20 mW Power, 2.3 V to 5.5 V, 75 MHz Complete DDS*. Analog Devices, Inc., 2011.

Kester, Walt. Chapter 3, Chapter 7, and Chapter 8, *The Data Conversion Handbook*. Analog Devices, Inc., 2005.

MT-015 Tutorial, *Basic DAC Architectures II: Binary DACs*. Analog Devices, Inc.

MT-031 Tutorial, *Grounding Data Converters and Solving the Mystery of AGND and DGND*. Analog Devices, Inc.

MT-034 Tutorial, *Current Feedback (CFB) Op Amps*. Analog Devices, Inc.

MT-085 Tutorial, *Fundamentals of Direct Digital Synthesis (DDS)*. Analog Devices, Inc.

MT-101 Tutorial, *Decoupling Techniques*. Analog Devices, Inc.

David Brandon and Ken Gentile. AN-837 Application Note, *DDS-Based Clock Jitter Performance vs. DAC Reconstruction Filter Performance*. Analog Devices, Inc.

Riordan, Liam. AN-1070 Application Note, *Programming the AD9833/AD9834*. Analog Devices, Inc.

Data Sheets and Evaluation Boards

AD9834 Data Sheet.

AD8014 Data Sheet.

REVISION HISTORY

4/14—Revision 0: Initial Version

(Continued from first page) Circuits from the Lab reference designs are intended only for use with Analog Devices products and are the intellectual property of Analog Devices or its licensors. While you may use the Circuits from the Lab reference designs in the design of your product, no other license is granted by implication or otherwise under any patents or other intellectual property by application or use of the Circuits from the Lab reference designs. Information furnished by Analog Devices is believed to be accurate and reliable. However, Circuits from the Lab reference designs are supplied "as is" and without warranties of any kind, express, implied, or statutory including, but not limited to, any implied warranty of merchantability, noninfringement or fitness for a particular purpose and no responsibility is assumed by Analog Devices for their use, nor for any infringements of patents or other rights of third parties that may result from their use. Analog Devices reserves the right to change any Circuits from the Lab reference designs at any time without notice but is under no obligation to do so.

©2014 Analog Devices, Inc. All rights reserved. Trademarks and registered trademarks are the property of their respective owners.
CN12064-0-4/14(0)

