

Spezifikation für Freigabe / specification for release

Kunde / customer :
 Artikelnummer / part number : **7498011001A**
 Bezeichnung : **LAN-Übertrager WE-RJ45LAN 10/100BaseT**
 description : **LAN-Transformer WE-RJ45LAN 10/100BaseT**



DATUM / DATE : 2014-03-24

H Schaltbild / Schematics :

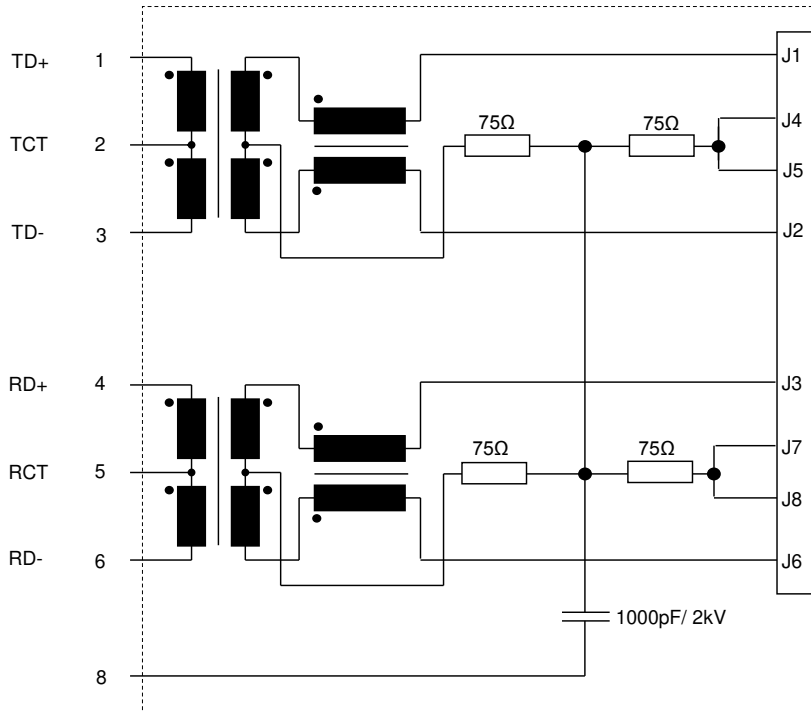

Freigabe erteilt / general release:	Kunde / customer			
.....	Mle	Rev 04	2014-03-24
Datum / date	Unterschrift / signature	Mle	Rev 03	2013-03-04
.....	Würth Elektronik	Mle	Rev 02	2012-09-04
.....	Mle	Rev 01	2012-06-06
Geprüft / checked	Kontrolliert / approved	Mle	Rev 00	2010-11-23
		Name	Änderung / modification	Datum / date

Würth Elektronik eiSos GmbH & Co.KG

D-74638 Waldenburg · Max-Eyth-Straße 1 - 3 · Germany · Telefon (+49) (0) 7942 - 945 - 0 · Telefax (+49) (0) 7942 - 945 - 400
<http://www.we-online.com>

Spezifikation für Freigabe / specification for release

Kunde / customer :
 Artikelnummer / part number : **7498011001A**
 Bezeichnung : **LAN-Übertrager WE-RJ45LAN 10/100BaseT**
 description : **LAN-Transformer WE-RJ45LAN 10/100BaseT**



DATUM / DATE : 2014-03-24

I Verpackungsspezifikation / package specification :

Tray

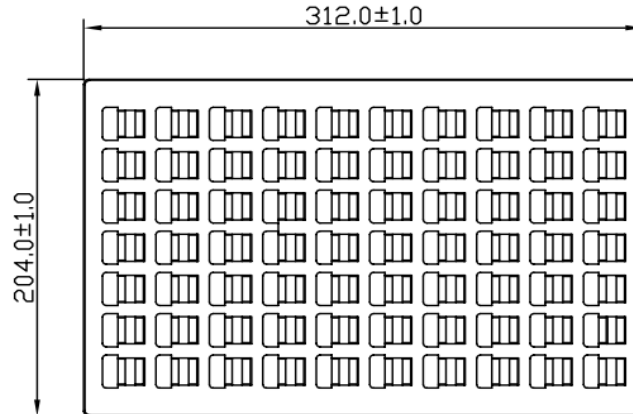

Carton

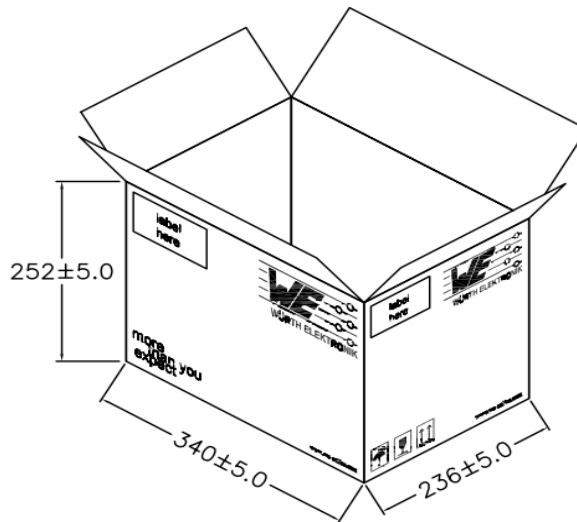

Packing Quantity:

tray= 70pcs
 carton= 840pcs

dimensions in mm

Freigabe erteilt / general release:	Kunde / customer			
.....	Mle	Rev 04	2014-03-24
Datum / date	Unterschrift / signature	Mle	Rev 03	2013-03-04
	Würth Elektronik	Mle	Rev 02	2012-09-04
		Mle	Rev 01	2012-06-06
.....	Mle	Rev 00	2010-11-23
Geprüft / checked	Kontrolliert / approved	Name	Änderung / modification	Datum / date

This electronic component has been designed and developed for usage in general electronic equipment. Before incorporating this component into any equipment where higher safety and reliability is especially required or if there is the possibility of direct damage or injury to human body, for example in the range of aerospace, aviation, nuclear control, submarine, transportation, (automotive control, train control, ship control), transportation signal, disaster prevention, medical, public information network etc, Würth Elektronik eiSos GmbH must be informed before the design-in stage. In addition, sufficient reliability evaluation checks for safety must be performed on every electronic component which is used in electrical circuits that require high safety and reliability functions or performance.

Würth Elektronik eiSos GmbH & Co.KG

D-74638 Waldenburg · Max-Eyth-Straße 1 · 3 · Germany · Telefon (+49) (0) 7942 - 945 - 0 · Telefax (+49) (0) 7942 - 945 - 400
<http://www.we-online.com>