



620-048 Strain Relief Self-Locking Rotatable Coupling - Straight and 90°

CONNECTOR DESIGNATOR

MIL-DTL-38999 Series I, II (F)
MIL-DTL-38999 Series III and IV (H)

F-H

SELF-LOCKING ROTATABLE COUPLING

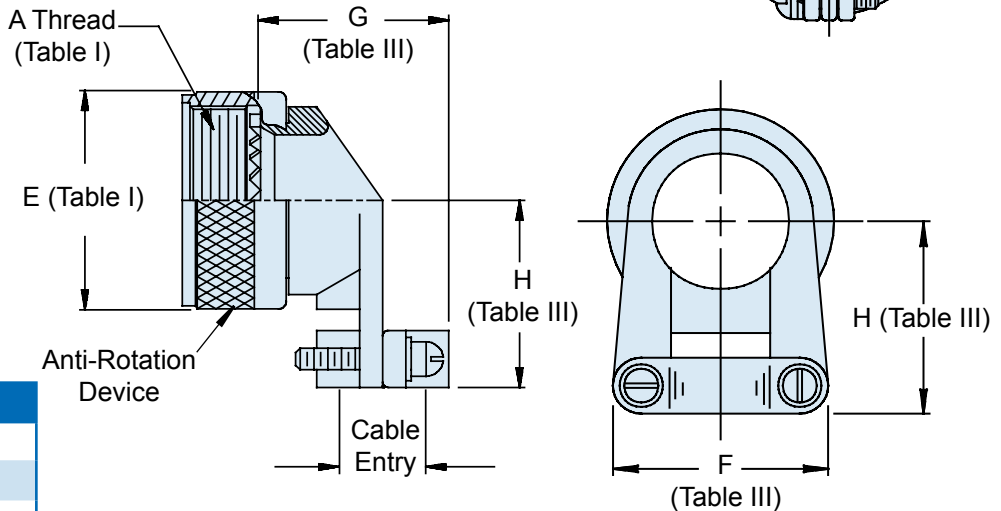
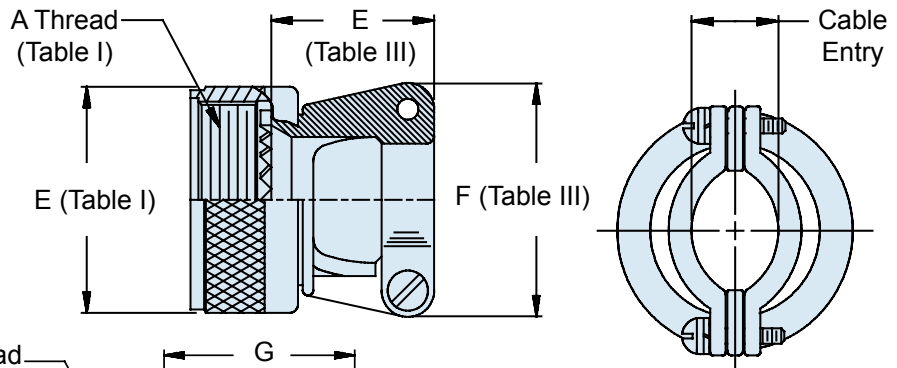
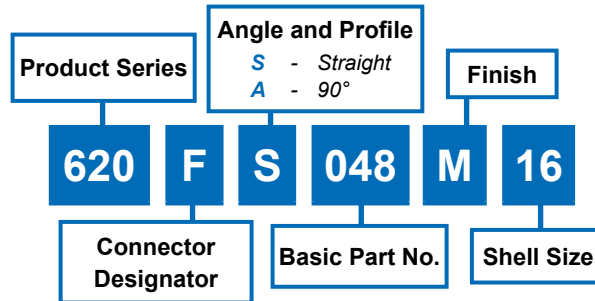

APPLICATION NOTES

1. Cable range is defined as the accommodation range for the wire bundle or cable. Dimensions shown are not intended for inspection criteria.
2. Metric dimensions (mm) are indicated in parentheses.

TABLE II: FINISHES

Symbol	Finish
B	Cadmium Plate, Olive Drab
C	Anodize, Black
G	Hard Coat, Anodic
GB	Black Anodize, Hard Coat
M	Electroless Nickel
N	Cad Plate, Olive Drab over Electroless Nickel
NF	Cadmium Plate, Olive Drab over Electroless Nickel
MT	Nickel Fluorocarbon Polymer
Z1	Stainless Steel Passivate
ZN	Zinc-Nickel

TABLE III: CABLE ENTRY

Shell Size	Cable Range		G Max	H Max	Cable Range Closed	Cable Range Open
	E Max	F Max				
08/09	.830 (21.1)	.780 (19.8)	.704 (17.9)	.808 (20.5)	.098 (2.5)	.234 (5.9)
10/11	.850 (21.6)	.832 (21.1)	.786 (20.0)	.867 (22.0)	.153 (3.9)	.234 (5.9)
12/13	.900 (22.9)	.988 (25.1)	.979 (24.9)	.929 (23.6)	.190 (4.8)	.328 (8.3)
14/15	.900 (22.9)	1.046 (26.6)	1.039 (26.4)	.992 (25.2)	.260 (6.6)	.457 (11.6)
16/17	.940 (23.9)	1.319 (33.5)	1.188 (30.2)	1.056 (26.8)	.283 (7.2)	.614 (15.6)
18/19	1.020 (25.9)	1.451 (36.9)	1.300 (33.0)	1.233 (31.3)	.325 (8.3)	.634 (16.1)
20/21	1.070 (27.2)	1.557 (39.5)	1.425 (36.2)	1.296 (32.9)	.343 (8.7)	.698 (17.7)
22/23	1.190 (30.2)	1.653 (42.0)	1.550 (39.4)	1.358 (34.5)	.381 (9.7)	.823 (20.9)
24/25	1.220 (31.0)	1.775 (45.1)	1.675 (42.5)	1.420 (36.1)	.418 (10.6)	.853 (21.7)