

MODEL NUMBER
ADT-2615-NF-BNM-02

NOTES:

- 1.0 MATERIALS:
 - 1.1 HOUSING: STAINLESS STEEL PER ASTM-A582, TYPE 303.
 - 1.2 BNC HOUSING: HALF HARD BRASS PER ASTM B16.
 - 1.3 CENTER CONTACT: BERYLLIUM COPPER ROD ALLOY C172, PER ASTM-B196.
 - 1.4 DIELECTRIC: PTFE FLUOROCARBON PER ASTM-D1457.
- 2.0 PLATING:
 - 2.1 HOUSING PASSIVATED PER MIL-F-14072 AND QQ-P-35.
 - 2.2 CENTER CONTACT: GOLD PER MIL-G-45204 TYPE II, CLASS 2.
 - 2.3 BNC HOUSING: NICKEL PER QQ-N-290.
- 3.0 ELECTRICAL SPECIFICATIONS:
 - 3.1 FREQUENCY RANGE: DC to 4.0 GHz.
 - 3.2 VSWR (MAXIMUM): 1.25:1
 - 3.3 IMPEDANCE: 50 OHMS
- 4.0 MARKING: MARK UNIT AS SHOWN (REF: INK-06819-27-04)
- 5.0 DIMENSIONS IN PARENTHESIS ARE IN MILLIMETERS.

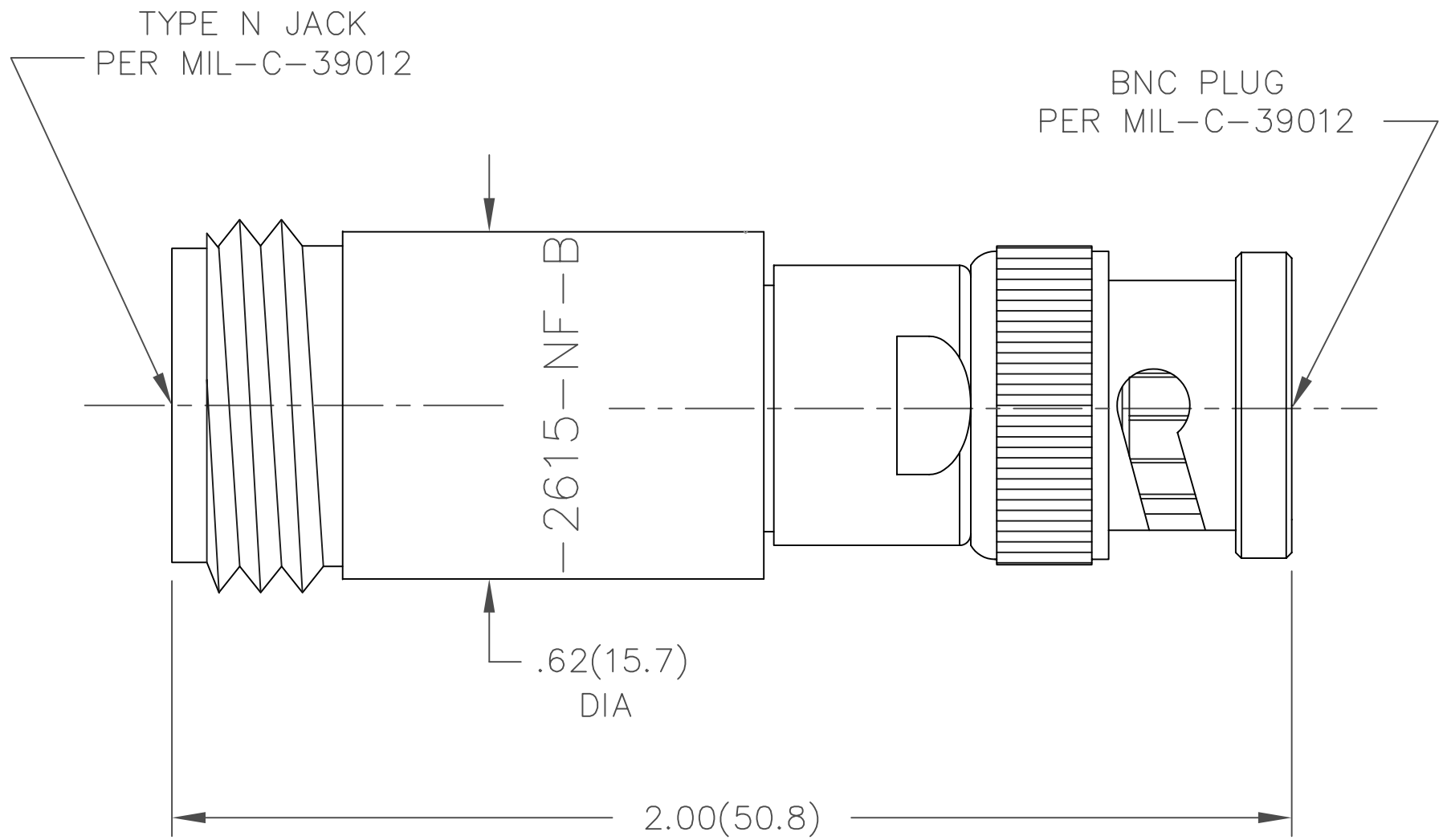

DWG. NO. WAS: 07028-01-00

NOTICE: The information contained in this drawing is proprietary and must not be used without the permission of Emerson Network Power.	CAGE CODE 34078		MIDWEST MICROWAVE	
			TITLE ADAPTER-BNC TO TYPE N OUTLINE DRAWING	
UNLESS OTHERWISE NOTED DIMENSIONS ARE IN INCHES AND TOLERANCES ARE: 3 PLACE DECIMALS ±.005 2 PLACE DECIMALS ±.02 FRACTIONS ±1/64 PARALLELITY: T.I.R. _____ FLATNESS: T.I.R. _____ CONCENTRICITY: T.I.R. _____ ANGLES AND PERPENDICULARITY: ±1°	DRAWN/DATE M.HOLLMAN 8/11/93	ENG./DATE A.OSGA 8/25/93	DRAWING NUMBER ADT-2615-NF-BNM-02-01	REV. C
CHECKED/DATE A.BEATTY 8/23/93	APPROVED/DATE	SCALE: 2=1	SHEET 1 of 1	

REV.	DESCRIPTION	DATE
-	RELEASED	8/11/93
A	ECR 6545	8/1/89
B	ECR 7159	2/16/90
C	CAD/UPDATE SPEC	8/11/93