

# OPTION G

- NOTES:
- MATERIAL:  
HOUSING: POLYESTER(PBT), GLASS FILLED, UL94 V-0;  
COLOR: BLACK  
TERMINAL: PHOSPHOR BRONZE
  - FINISH:  
15 GOLD: 0.38 MICROMETERS/15 MICROINCHES MINIMUM GOLD IN  
1.91 MICROMETERS/75 MICROINCHES MINIMUM TIN  
OVER NICKEL UNDERPLATE OVERALL
  - TO BE USED WITH 22 AWG STRANDED WIRE WITH (1.35)/.053  
DIAMETER MAXIMUM INSULATION
  - SEE TABLE FOR AVAILABLE CIRCUIT SIZES
  - STANDARD PACKAGING PER PK-70873-0001. OPTIONAL PACKAGING  
MAY BE AVAILABLE. REQUEST DRAWING PK-70400
  - PARTS STACKABLE END TO END (2.54)/.100 CENTERS
  - PRODUCT SPECIFICATION: PS-70400
  - SEE DRAWING SDA-70400-\*\*\*\* (SHEET 3) FOR OPTIONAL  
HOUSING DETAILS
  - 4 CIRCUIT SHOWN. 3-25 CIRCUITS HAVE 2 RIBS
  - TO MATE WITH MOLEX PART NUMBERS: A-70373-\*\*\*\*,  
A-70375-\*\*\*\*, A-70389-\*\*\*\*, A-70391-\*\*\*\*,  
A-70107-\*\*\*\*, A-70018-\*\*\*\*, A-70543-\*\*\*\*,  
A-70553-\*\*\*\*, A-70541-\*\*\*\*, A-70551-\*\*\*\*,  
A-70545-\*\*\*\*, A-70555-\*\*\*\*
  - 2 CIRCUIT ASSEMBLIES SUPPLIED AS GROUPED PAIRS

CKT. SIZE	A	B	EDP. NO.
2	( 2.54 ) .100	( 5.05 ) .199	14-56-7027
3	( 5.08 ) .200	( 7.59 ) .299	14-56-7037
4	( 7.62 ) .300	( 10.13 ) .399	14-56-7047
5	( 10.16 ) .400	( 12.67 ) .499	14-56-7057
6	( 12.70 ) .500	( 15.21 ) .599	14-56-7067
7	( 15.24 ) .600	( 17.75 ) .699	14-56-7077
8	( 17.78 ) .700	( 20.29 ) .799	14-56-7087
9	( 20.32 ) .800	( 22.83 ) .899	14-56-7097
10	( 22.86 ) .900	( 25.37 ) .999	14-56-7107
11	( 25.40 ) 1.000	( 27.91 ) 1.099	14-56-7117
12	( 27.94 ) 1.100	( 30.45 ) 1.199	14-56-7127
13	( 30.48 ) 1.200	( 32.99 ) 1.299	14-56-7137
14	( 33.02 ) 1.300	( 35.53 ) 1.399	14-56-7147
15	( 35.56 ) 1.400	( 38.07 ) 1.499	14-56-7157
16	( 38.10 ) 1.500	( 40.61 ) 1.599	14-56-7167
17	( 40.64 ) 1.600	( 43.15 ) 1.699	14-56-7177
18	( 43.18 ) 1.700	( 45.69 ) 1.799	14-56-7187
19	( 45.72 ) 1.800	( 48.23 ) 1.899	14-56-7197
20	( 48.26 ) 1.900	( 50.77 ) 1.999	14-56-7207
21	( 50.80 ) 2.000	( 53.31 ) 2.099	14-56-7217
22	( 53.34 ) 2.100	( 55.85 ) 2.199	14-56-7227
23	( 55.88 ) 2.200	( 58.39 ) 2.299	14-56-7237
24	( 58.42 ) 2.300	( 60.93 ) 2.399	14-56-7247
25	( 60.96 ) 2.400	( 63.47 ) 2.499	14-56-7257

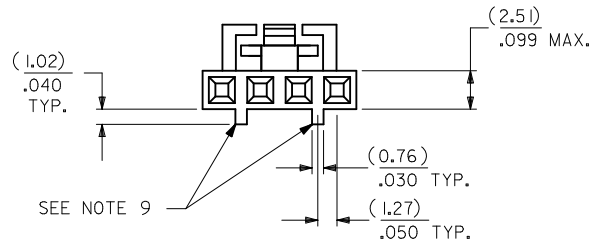

CIRCUIT NO. 1  
SLOT OR ARROW

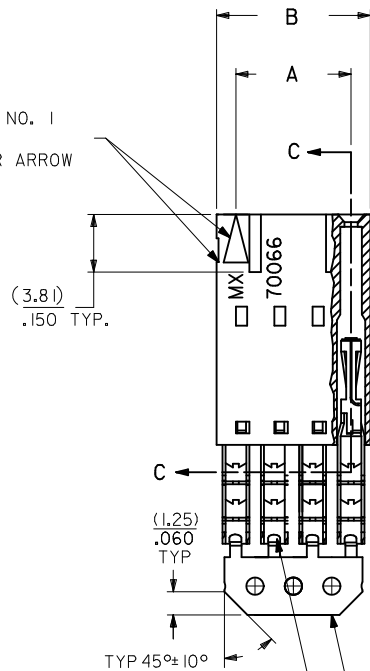

## SECTION C-C

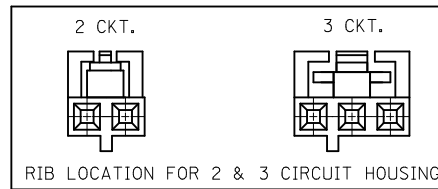
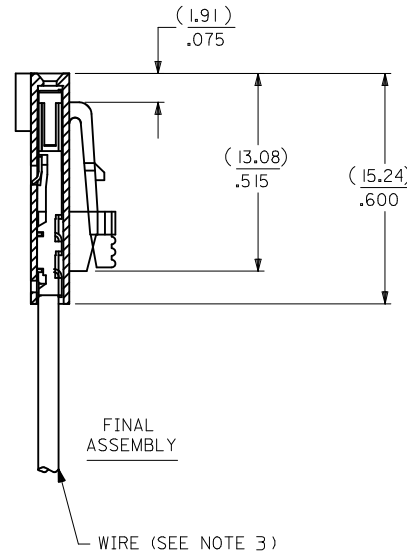
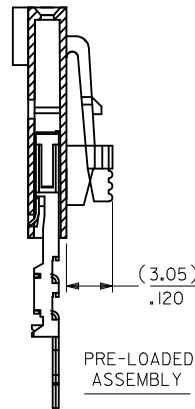

I.D. SLOT CODE TO WIRE GAUGE CHART	
I.D. SLOT CODE	WIRE GAUGE
D	22 AWG.

PLATING CODE (STRIPE ON CARRIER STRIP)	
PLATING	COLOR
15 GOLD	YELLOW

REMOVE ENG NO. EC NO: UCP2011-110 DRWINMSI BARRA 2010/10/19 CHKD:JORGAN 2010/10/19 APPR:SMILLER 2010/11/24	QUALITY SYMBOLS ▽=0 ▽=0 ▽=0	GENERAL TOLERANCES (UNLESS SPECIFIED) mm INCH 4 PLACES ± --- ± --- 3 PLACES ± --- ± .010 2 PLACES ± 0.25 ± .014 1 PLACE ± 0.35 ± --- ANGULAR ±1/2°	DIMENSION STYLE MM/IN DRAWN BY DATE MSIBARRA 2010/10/20 CHECKED BY DATE WAZ 1987/10/26 APPROVED BY DATE SMILLER 2010/11/24	SCALE DESIGN UNITS INCH THIRD ANGLE PROJECTION	TITLE ASSEMBLY, SL CONNECTOR SINGLE ROW 2.54/.100
		DRAFT WHERE APPLICABLE MUST REMAIN WITHIN DIMENSIONS	MATERIAL NO. SEE TABLE	DOCUMENT NO. SDA-70400-2976-2999	SHEET NO. 1 OF 1
		THIS DRAWING CONTAINS INFORMATION THAT IS PROPRIETARY TO MOLEX INCORPORATED AND SHOULD NOT BE USED WITHOUT WRITTEN PERMISSION			
		MOLEX INCORPORATED			

# OPTION G

- NOTES:
- MATERIAL:  
HOUSING: POLYESTER(PBT), GLASS FILLED, UL94 V-0;  
COLOR: BLACK  
TERMINAL: PHOSPHOR BRONZE
  - FINISH:  
15 GOLD: 0.38 MICROMETERS/15 MICROINCHES MINIMUM GOLD IN  
1.91 MICROMETERS/75 MICROINCHES MINIMUM TIN  
OVER NICKEL UNDERPLATE OVERALL
  - TO BE USED WITH 22 AWG STRANDED WIRE WITH (1.35)/.053  
DIAMETER MAXIMUM INSULATION
  - SEE TABLE FOR AVAILABLE CIRCUIT SIZES
  - STANDARD PACKAGING PER PK-70873-0001. OPTIONAL PACKAGING  
MAY BE AVAILABLE. REQUEST DRAWING PK-70400
  - PARTS STACKABLE END TO END ON (2.54)/.100 CENTERS
  - PRODUCT SPECIFICATION: PS-70400
  - SEE DRAWING SDA-70400-\*\*\*\* (SHEET 3) FOR OPTIONAL  
HOUSING DETAILS
  - 4 CIRCUIT SHOWN. 3-25 CIRCUITS HAVE 2 RIBS
  - TO MATE WITH MOLEX PART NUMBERS: A-70373-\*\*\*\*,  
A-70375-\*\*\*\*, A-70389-\*\*\*\*, A-70391-\*\*\*\*,  
A-70107-\*\*\*\*, A-70018-\*\*\*\*, A-70543-\*\*\*\*,  
A-70553-\*\*\*\*, A-70541-\*\*\*\*, A-70551-\*\*\*\*,  
A-70545-\*\*\*\*, A-70555-\*\*\*\*
  - 2 CIRCUIT ASSEMBLIES SUPPLIED AS GROUPED PAIRS

CKT. SIZE	A	B	EDP. NO.
2	( 2.54 ) .100	( 5.05 ) .199	14-56-7027
3	( 5.08 ) .200	( 7.59 ) .299	14-56-7037
4	( 7.62 ) .300	( 10.13 ) .399	14-56-7047
5	( 10.16 ) .400	( 12.67 ) .499	14-56-7057
6	( 12.70 ) .500	( 15.21 ) .599	14-56-7067
7	( 15.24 ) .600	( 17.75 ) .699	14-56-7077
8	( 17.78 ) .700	( 20.29 ) .799	14-56-7087
9	( 20.32 ) .800	( 22.83 ) .899	14-56-7097
10	( 22.86 ) .900	( 25.37 ) .999	14-56-7107
11	( 25.40 ) 1.000	( 27.91 ) 1.099	14-56-7117
12	( 27.94 ) 1.100	( 30.45 ) 1.199	14-56-7127
13	( 30.48 ) 1.200	( 32.99 ) 1.299	14-56-7137
14	( 33.02 ) 1.300	( 35.53 ) 1.399	14-56-7147
15	( 35.56 ) 1.400	( 38.07 ) 1.499	14-56-7157
16	( 38.10 ) 1.500	( 40.61 ) 1.599	14-56-7167
17	( 40.64 ) 1.600	( 43.15 ) 1.699	14-56-7177
18	( 43.18 ) 1.700	( 45.69 ) 1.799	14-56-7187
19	( 45.72 ) 1.800	( 48.23 ) 1.899	14-56-7197
20	( 48.26 ) 1.900	( 50.77 ) 1.999	14-56-7207
21	( 50.80 ) 2.000	( 53.31 ) 2.099	14-56-7217
22	( 53.34 ) 2.100	( 55.85 ) 2.199	14-56-7227
23	( 55.88 ) 2.200	( 58.39 ) 2.299	14-56-7237
24	( 58.42 ) 2.300	( 60.93 ) 2.399	14-56-7247
25	( 60.96 ) 2.400	( 63.47 ) 2.499	14-56-7257

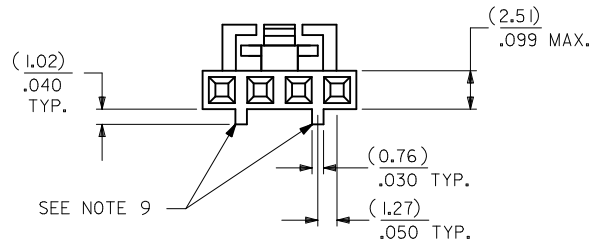

CIRCUIT NO. 1  
SLOT OR ARROW

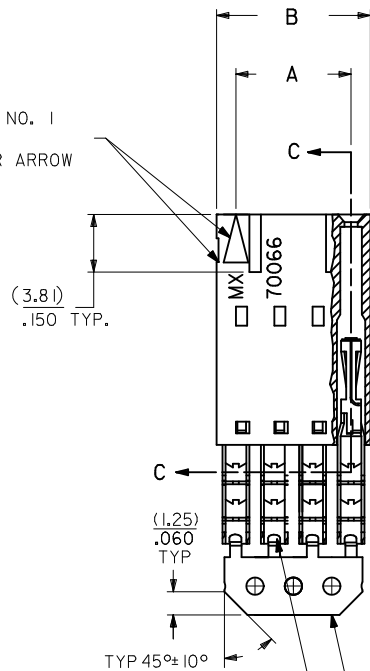

## SECTION C-C

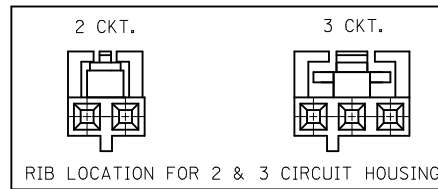
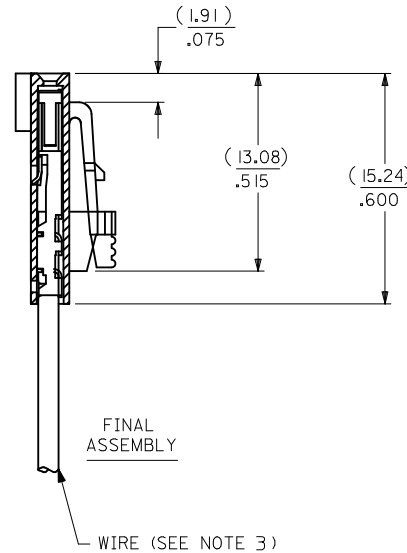
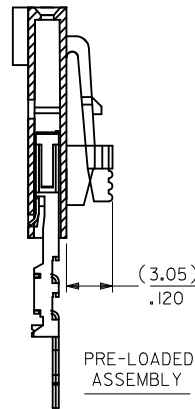

I.D. SLOT CODE TO WIRE GAUGE CHART	
I.D. SLOT CODE	WIRE GAUGE
D	22 AWG.

PLATING CODE (STRIPE ON CARRIER STRIP)	
PLATING	COLOR
15 GOLD	YELLOW

REMOVE ENG NO. EC NO: UCP2011-110 DRWINMSI BARRA 2010/10/19 CHKD:JORGAN 2010/10/19 APPR:SMILLER 2010/11/24	QUALITY SYMBOLS ▽=0 ▽=0 ▽=0	GENERAL TOLERANCES (UNLESS SPECIFIED)		DIMENSION STYLE MM/IN		SCALE	DESIGN UNITS	THIRD ANGLE PROJECTION			
		4 PLACES ± --- ± --- 3 PLACES ± --- ± .010 2 PLACES ± 0.25 ± .014 1 PLACE ± 0.35 ± ---		DRAWN BY DATE MSIBARRA 2010/10/20		TITLE	ASSEMBLY, SL CONNECTOR SINGLE ROW 2.54/.100				
		ANGULAR ±1/2°		CHECKED BY DATE WAZ 1987/10/26		APPROVED BY DATE SMILLER 2010/11/24		MOLEX MOLEX INCORPORATED			
		DRAFT WHERE APPLICABLE MUST REMAIN WITHIN DIMENSIONS		MATERIAL NO. SEE TABLE		DOCUMENT NO. SDA-70400-2976-2999		SHEET NO. 1 OF 1			