



Part Number: DMC2652

Electrical Specifications

Frequency Range (GHz):	2.6 - 5.2
Isolation (dB):	15 MIN
Insertion Loss (dB):	1.0 MAX
VSWR:	1.5:1 MIN
Forward Power (W):	20 AVG 30 PK

Mechanical/Environmental Specifications

Connector Type:	SMA
Connector Body:	Passivated stainless steel
Connector Pin:	Gold plated copper
Load Body:	Brass
Magnetic Shunt:	Nickel plated CRS
Operational Temp:	-30°C to +75°C
Weight (oz)	1.0 MAX

DMC2652 Dimensions

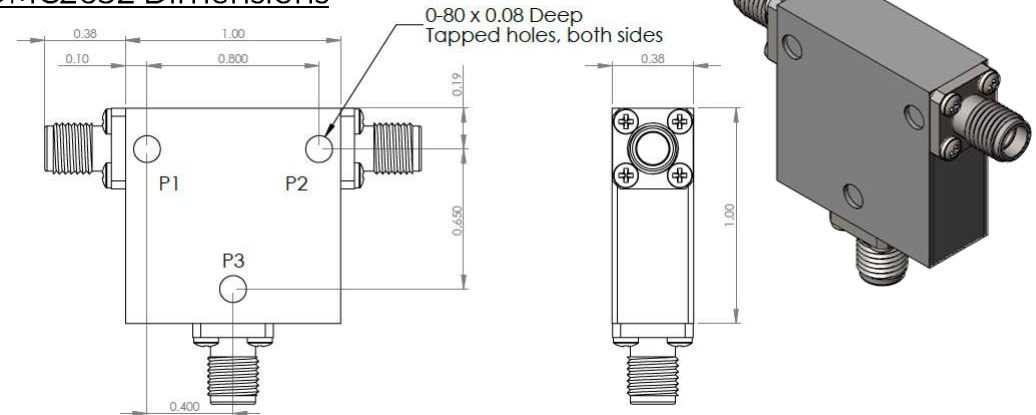

DMC2652-3 Dimensions

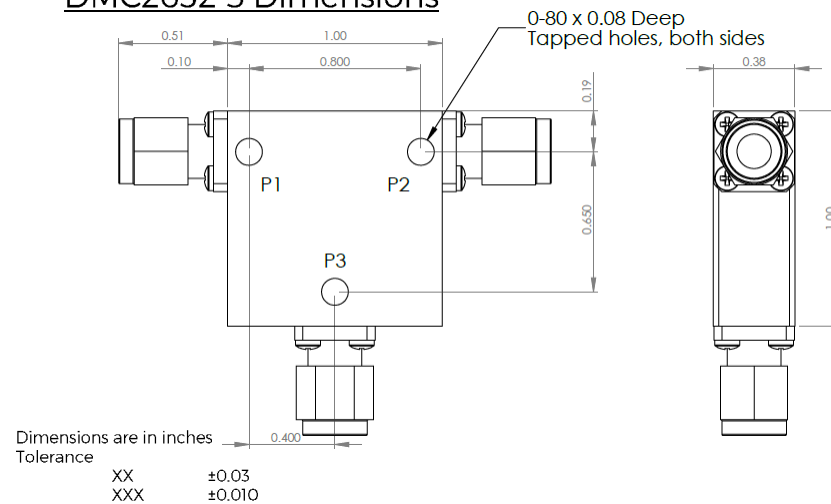

Type of Device	PN Suffix	Connector Configuration Input / Output	PN Example
Single Junction Circulator 3-Port Device Port 1 / Port 2 / Port 3	No Dash	Female / Female / Female	DMC2652
	-1	Male / Female / Female	DMC2652-1
	-2	Female / Male / Female	DMC2652-2
	-3	Male / Male / Male	DMC2652-3
	-4	Female / Female / Male	DMC2652-4
	-5	Male / Female / Male	DMC2652-5
	-6	Male / Male / Female	DMC2652-6
-7	Female / Male / Male	DMC2652-7	



MEASURED DATA

Part Number: DMC2652, P1→P2, P3 Terminated with 50Ω, +25°C

