

Polymer PTC Resettable Fuse: KRG Series

30Vdc Radial Leded Type



■ Features

1. RoHS & Halogen-Free (HF) compliant
2. Radial leaded devices
3. Broadest range of resettable devices available in the industry
4. Hold current ratings from 0.9 to 9A
5. Maximum voltage is 30Vdc
6. Operating & storage temperature range: -40 ~ +85°C
7. Agency Recognition: UL / cUL / TUV

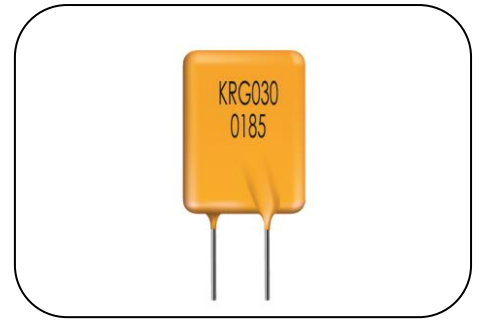

■ Recommended Applications

1. Motors / fans
2. Keyboard / mouse
3. Transformers
4. Industrial controls
5. Automotive electronics

■ Part Number Code

K	R	G	0	3	0	0	1	3	5	I	B	Y			
1	2	3	4	5	6	7	8	9	10	11	12	13	14	15	16

Product Type		Form Factor		Usage		Max. Operating Voltage (Vmax)		I hold		Appearance		Packaging	
K	THINKING Polymer PTC Resettable Fuse	R	Radial	G	General	030	30V	0090	0.9A	S	Straight lead	B	Bulk
								0135	1.35A	I	Inner kink lead	A	Ammo Taping
								0600	6A			R	Reel Taping
								0900	9A				

Optional Suffix	
Y	RoHS & HF Compliant

■ Structure and Dimensions

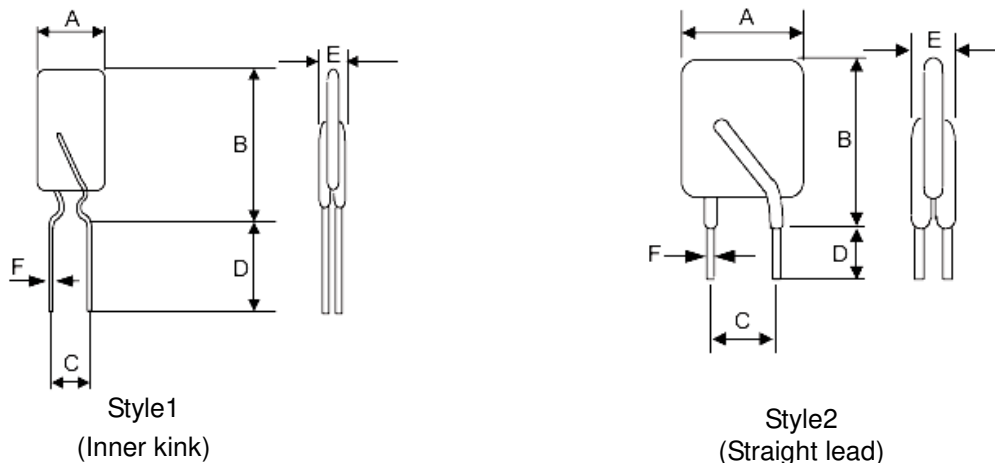

Marking: Device is marked with product type, Vmax, and I hold.

Polymer PTC Resettable Fuse: KRG Series

30Vdc Radial Leaded Type



(Unit: mm)

Part no.	A		B				C		D		E		F		Figure
	Min.	Max.	. Straight Lead		Inner Kink		Min.	Max.	Min.	Max.	Min.	Max.	Min.	Max.	Style
			Min.	Max.	Min.	Max.									
KRG0300090	5.1	7.4	6.6	12.2	6.6	12.2	4.2	5.8	7.6	11.6	1.4	3.0	0.48	0.52	1,2
KRG0300110	5.1	7.4	8.6	14.2	8.6	14.2	4.2	5.8	7.6	11.6	1.4	3.0	0.48	0.52	1,2
KRG0300135	7.6	8.9	7.6	13.5	7.6	13.5	4.2	5.8	7.6	11.6	1.4	3.0	0.48	0.52	1,2
KRG0300160	7.6	8.9	9.3	15.2	9.3	15.2	4.2	5.8	7.6	11.6	1.4	3.0	0.48	0.52	1,2
KRG0300185	8.6	10.2	10.2	15.7	10.2	15.7	4.2	5.8	7.6	11.6	1.4	3.0	0.48	0.52	1,2
KRG0300250	10.2	11.4	12.4	18.3	12.4	20.5	4.2	5.8	7.6	11.6	1.4	3.0	0.48	0.52	1,2
KRG0300300	10.2	11.4	12.4	17.3	12.4	21.8	4.2	5.8	7.6	11.6	1.8	3.5	0.78	0.82	1,2
KRG0300400	12.7	14.0	14.2	20.1	14.2	24.6	4.2	5.8	7.6	11.6	1.8	3.5	0.78	0.82	1,2
KRG0300500	12.7	14.0	19.0	24.9	19.0	26.6	9.2	10.8	7.6	11.6	1.8	3.5	0.78	0.82	1,2
KRG0300600	15.2	16.5	19.0	24.9	19.0	29.4	9.2	10.8	7.6	11.6	1.8	3.5	0.78	0.82	1,2
KRG0300700	17.8	19.1	20.8	26.7	20.8	31.2	9.2	10.8	7.6	11.6	1.8	3.5	0.78	0.82	1,2
KRG0300800	20.3	21.6	23.4	29.2	23.4	33.7	9.2	10.8	7.6	11.6	1.8	3.5	0.78	0.82	1,2
KRG0300900	22.9	24.1	22.9	29.7	22.9	34.2	9.2	10.8	7.6	11.6	1.8	3.5	0.78	0.82	1,2

■ Electrical Characteristics at 23°C

Part no.	Vmax.	I _{max} .	I _{hold}	I _{trip}	P _d (Typ.)	Maximum Time to Trip		Resistance			Safety Approvals	
	(V _{dc})	(A)	(A)	(A)	(W)	Current	Time	Initial R _i		Post Trip R ₁	UL/ cUL	TUV
						(A)	(Sec)	Min. (Ω)	Max. (Ω)	Max.(Ω)		
KRG0300090	30	40	0.90	1.80	0.60	4.50	5.90	0.070	0.120	0.220	√	√
KRG0300110	30	40	1.10	2.20	0.70	5.50	6.60	0.050	0.100	0.170	√	√
KRG0300135	30	40	1.35	2.70	0.80	6.75	7.30	0.040	0.080	0.130	√	√
KRG0300160	30	40	1.60	3.20	0.90	8.00	8.00	0.030	0.070	0.110	√	√
KRG0300185	30	40	1.85	3.70	1.00	9.25	8.70	0.030	0.060	0.090	√	√
KRG0300250	30	40	2.50	5.00	1.20	12.50	10.30	0.020	0.040	0.070	√	√
KRG0300300	30	40	3.00	6.00	2.00	15.00	10.80	0.020	0.050	0.080	√	√
KRG0300400	30	40	4.00	8.00	2.50	20.00	12.70	0.010	0.030	0.050	√	√
KRG0300500	30	40	5.00	10.00	3.00	25.00	14.50	0.010	0.030	0.050	√	√
KRG0300600	30	40	6.00	12.00	3.50	30.00	16.00	0.005	0.020	0.040	√	√
KRG0300700	30	40	7.00	14.00	3.80	35.00	17.50	0.005	0.020	0.030	√	√
KRG0300800	30	40	8.00	16.00	4.00	40.00	18.80	0.005	0.013	0.020	√	√
KRG0300900	30	40	9.00	18.00	4.20	40.00	20.00	0.005	0.010	0.020	√	√

Note: UL&cUL File No: E138827

TUV File No: J 50161442

Polymer PTC Resettable Fuse: KRG Series

30Vdc Radial Leaded Type



■ Typical Time to Trip Curves at 23°C

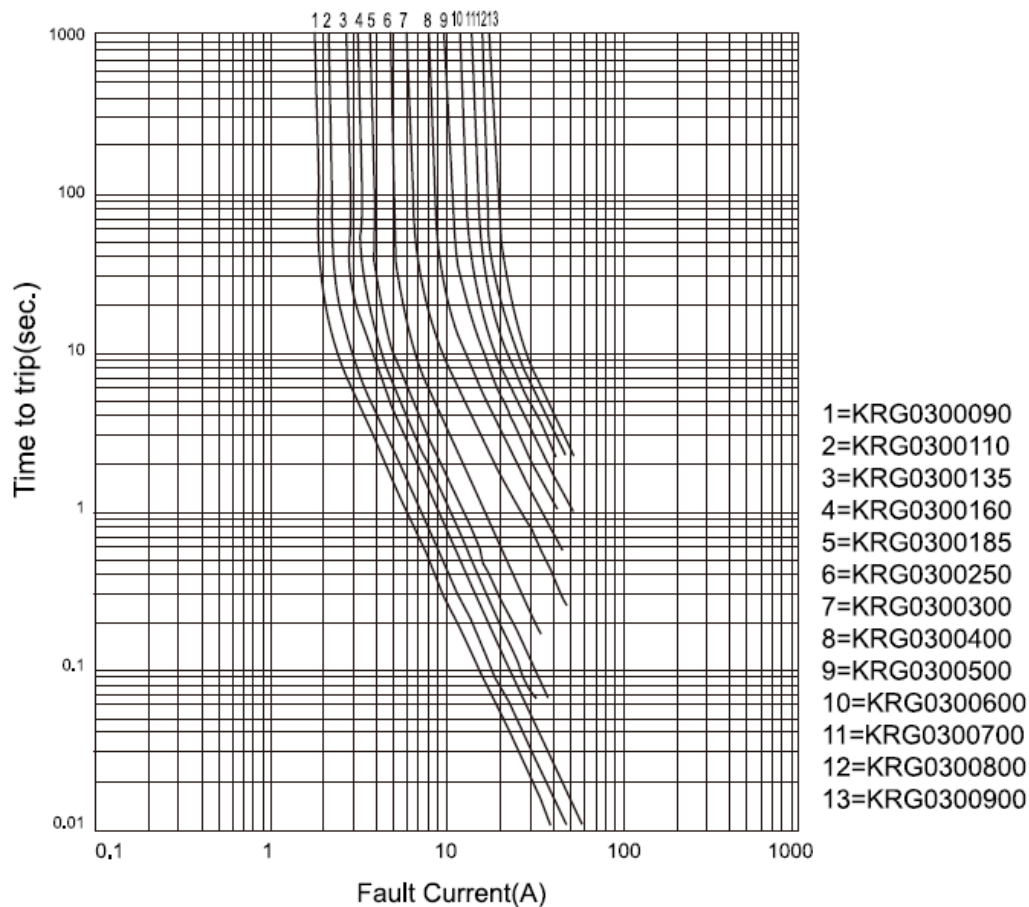

■ Ihold & Itrip Thermal Derating Curve

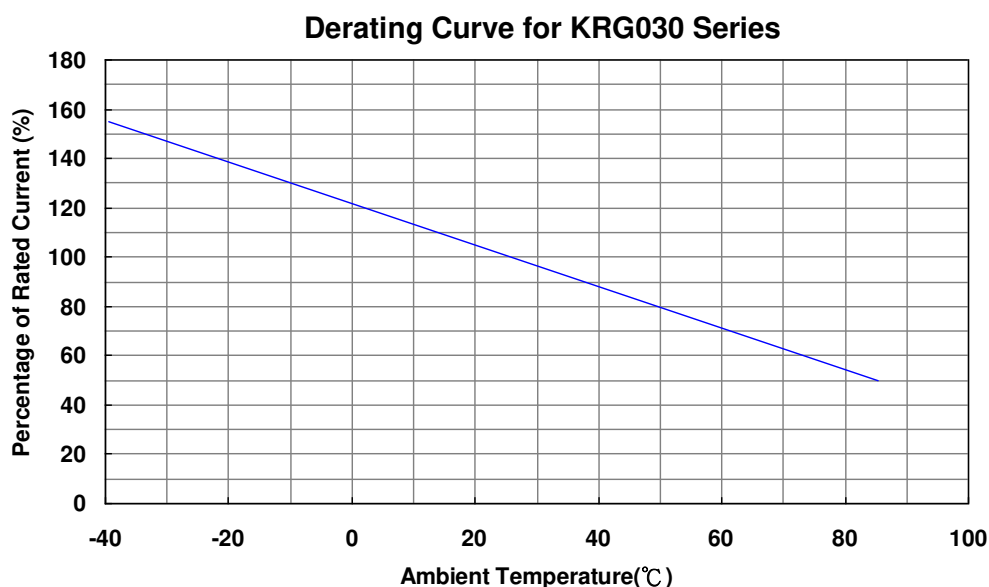

Polymer PTC Resettable Fuse: KRG Series

30Vdc Radial Leaded Type



■ Hold Thermal Derating Chart

(Unit: A)

Part no.	Ambient Temperature								
	-40℃	-20℃	0℃	23℃	40℃	50℃	60℃	70℃	85℃
KRG0300090	1.38	1.22	1.08	0.90	0.78	0.70	0.62	0.55	0.45
KRG0300110	1.68	1.50	1.32	1.10	0.96	0.86	0.76	0.67	0.55
KRG0300135	2.07	1.84	1.62	1.35	1.17	1.05	0.92	0.82	0.68
KRG0300160	2.45	2.18	1.92	1.60	1.39	1.25	1.09	0.98	0.80
KRG0300185	2.83	2.52	2.22	1.85	1.61	1.44	1.25	1.13	0.93
KRG0300250	3.83	3.40	3.00	2.50	2.18	1.95	1.71	1.53	1.25
KRG0300300	4.59	4.08	3.60	3.00	2.61	2.34	2.05	1.83	1.50
KRG0300400	6.12	5.44	4.80	4.00	3.48	3.12	2.72	2.44	2.00
KRG0300500	7.65	6.80	6.00	5.00	4.35	3.90	3.41	3.05	2.50
KRG0300600	9.18	8.16	7.20	6.00	5.22	4.68	4.09	3.66	3.00
KRG0300700	10.71	9.52	8.40	7.00	6.09	5.46	4.77	4.27	3.50
KRG0300800	12.24	10.88	9.60	8.00	6.96	6.24	5.45	4.88	4.00
KRG0300900	13.77	12.24	10.80	9.00	7.83	7.02	6.12	5.49	4.50

■ Reliability

Item	Standard	Test Condition/methods	Criteria
Resistance to Soldering Heat	IEC 60068-2-58	260 ± 5 °C , 10 ± 1 sec	Rf < R1max No visible damage
Passive Aging	IEC 60738-1	85±5℃, 1000±24hrs	±5% typical resistance change
Humidity Aging	IEC 60068-2-78	85±5℃, 80~85%RH, 1000±5hrs	±5% typical resistance change
Rapid Change of Temperature	IEC 60738-1	85±5/-40±5℃, 10 cycles, Duration:30min	±5% typical resistance change
Overload Endurance	UL 1434	Vmax, 120% Imax, 50 cycles Vmax, 300% Itrip, 6000 cycles	No visible damage
Trip Endurance	UL 1434	Vmax, Itrip ≤ I ≤ Imax, 1000±24hrs	No visible damage

Polymer PTC Resettable Fuse: KRG Series

30Vdc Radial Leaded Type



■ Packaging

Devices are taped according to IEC 60286-2 standards. See table below and Fig. 1~3 for details.

Dimension description	IEC Mark	Dimension (mm)	Tolerance (mm)
Sprocket hole pitch	P ₀	12.70	±0.3
Ordinate to adjacent component lead KRG0300090~KRG0300400	P ₁	3.85	±0.7
Ordinate to adjacent component lead KRG0300500~KRG0300900		7.70	±0.7
Device pitch KRG0300090~KRG0300300	P	12.70	±1.0
Device pitch KRG0300400~KRG0300900		25.40	±1.0
Lead spacing KRG0300090~KRG0300400	F	5.00	±0.8
Lead spacing KRG0300500~KRG0300900		10.00	
Lead diameter KRG0300090~KRG0300250	d	0.50	±0.02
Lead diameter KRG0300300~KRG0300900		0.80	
Carrier tape width	W	18.00	+1/-0.5
Top distance between tape edges	W ₂	3.00	Max
Hold-down tape width	W ₀	12.00	±1.5
Sprocket hole position	W ₁	9.00	+0.75/-0.5
Abscissa to top KRG0300090~KRG0300300	H ₁	32.20	Max.
Abscissa to top KRG0300400~KRG0300900		47.50	
Abscissa to plane (straight lead)	H	18.00	+2/-0
Abscissa to plane (kinked lead)	H ₀	16.00	±0.5
Sprocket hole diameter	D ₀	4.00	±0.2
Lead protrusion	L ₁	0.50	Max.
Tape thickness	T	0.60	±0.2
Body lateral deviation	Δh	2.00	Max.
Body tape plane deviation	Δp	1.00	Max.
Reel width	W ₃	See reel specification	±1
Reel diameter		340.00	±10
Arbor hole diameter	n ₀	31.00	±1
Core diameter	n	80.00	Min.

Polymer PTC Resettable Fuse: KRG Series

30Vdc Radial Leded Type



● Taping Specification

Fig.1 For KRG0300090~KRG0300400

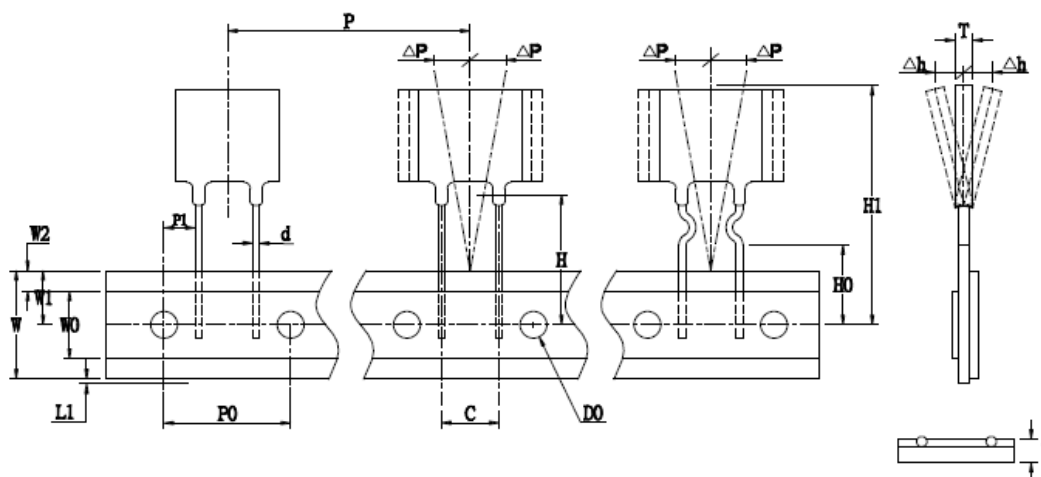
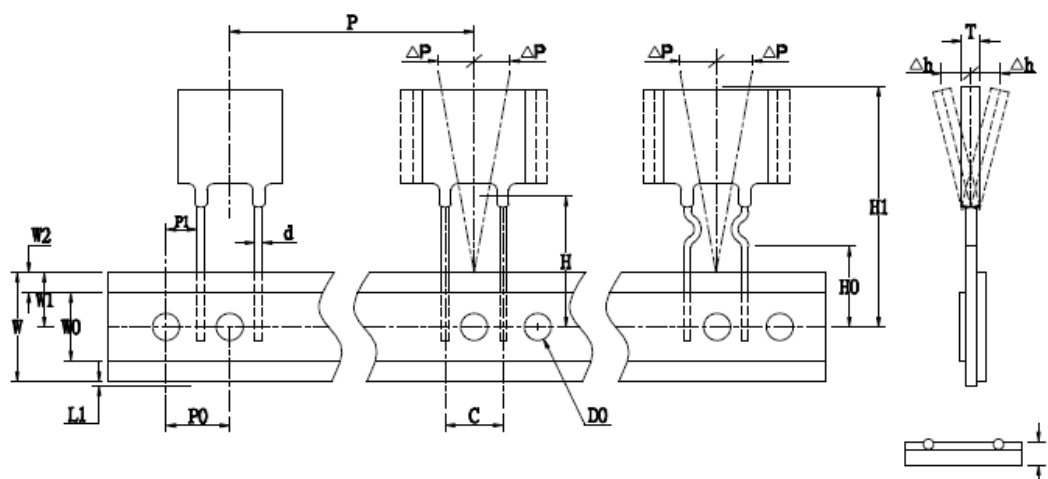
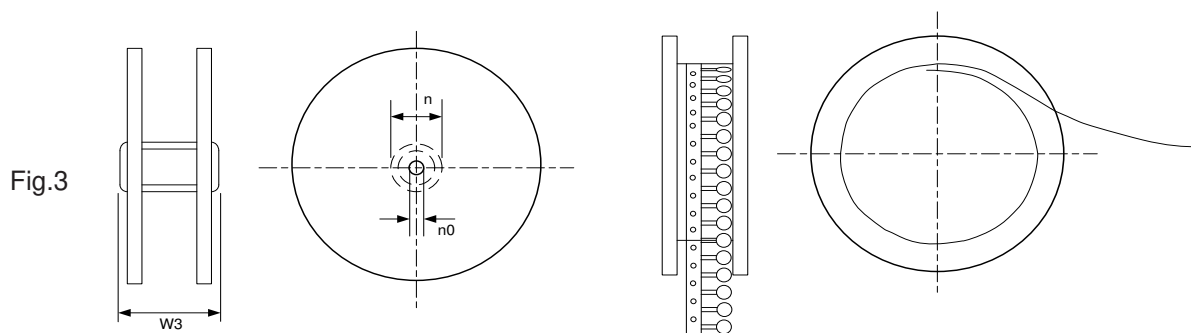

Fig.2 For KRG0300500~KRG0300900



● Reel Specification



Series	W3 (mm)
KRG030 (0090~0400)	46±1
KRG030 (0500~0700)	52±1
KRG030 (0800~0900)	55±1

Polymer PTC Resettable Fuse: KRG Series

30Vdc Radial Leaded Type



■ Quantity

● Bulk Packing

Series	Quantity (pcs/bag)
KRG030 (0090~0135)	1,000
KRG030 (0160~0600)	500
KRG030 (0700)	200
KRG030 (0800~0900)	250

● Reel Packing

Series	Quantity (pcs/reel)
KRG030 (0090~0135)	3,000
KRG030 (0160~0300)	2,000
KRG030 (0400~0900)	1,000

● Ammo Packing

Series	Quantity (pcs/box)
KRG030 (0090~0300)	1,000
KRG030 (0400~0900)	500

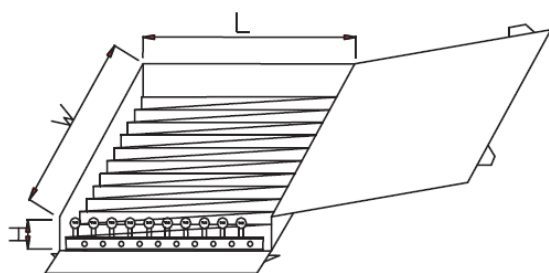

(Unit: mm)

Series	W	L	H
KRG030 (0090~0900)	345	275	55

■ Warehouse Storage Conditions of Products

- Storage Conditions:
 1. Storage Temperature: $-10^{\circ}\text{C} \sim +40^{\circ}\text{C}$
 2. Relative Humidity: $\leq 75\% \text{RH}$
 3. Keep away from corrosive atmosphere and sunlight.
- Period of Storage: 1 year