

P/N OF ADAPTER	MATERIAL OF SLEEVE	TYPE	COLOR
106166-1100	ZR	SINGLE MODE	BLUE
106167-1100	PHOSPHOR BRONZE		
106166-1110	ZR	MULTIMODE	BEIGE
106167-1110	PHOSPHOR BRONZE		
106166-1130	ZR		
106167-1130	PHOSPHOR BRONZE		
106167-1120	ZR		AQUA

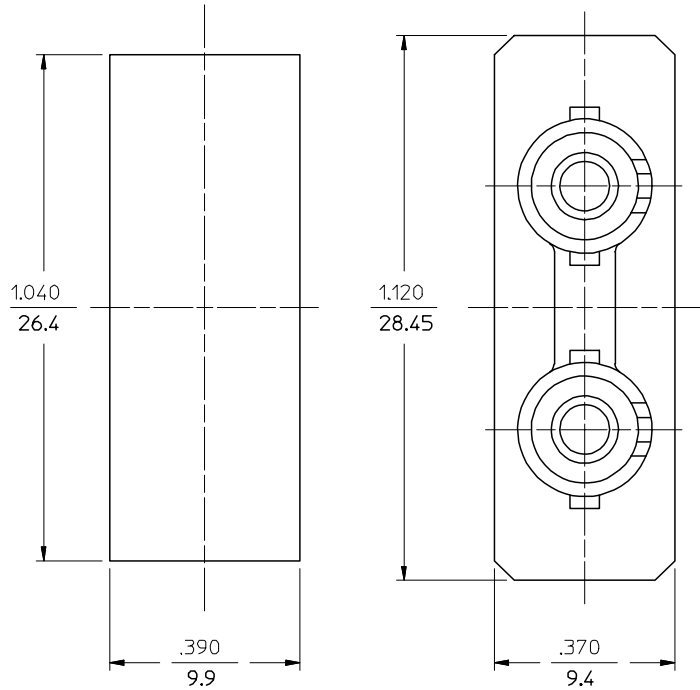

RECOMMENDED MOUNTING HOLE

NOTES:
DUST CAPS ARE NOT SHOWN, BUT INCLUDED.

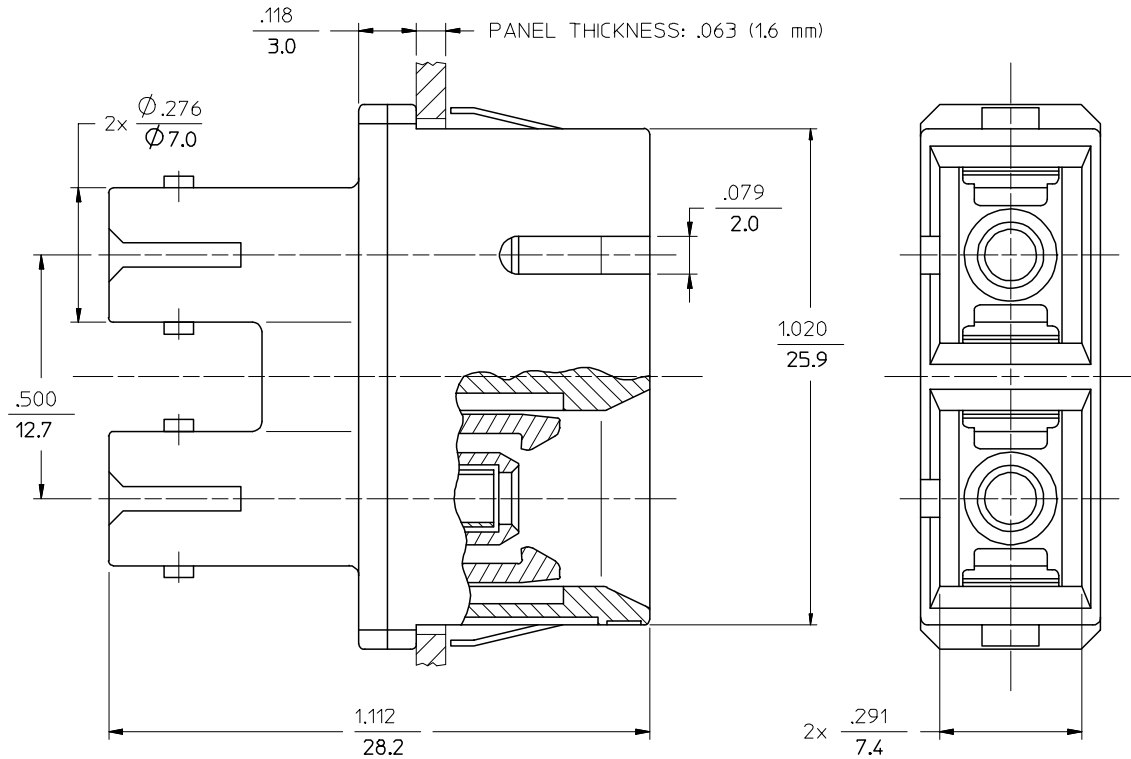

ENTER DESCRIPTION EC NO: MF2006-0237 DRWN:PGIBLIN CHKD: APPR:IGUMIN	QUALITY SYMBOLS ▽=0 ▽=0	GENERAL TOLERANCES (UNLESS SPECIFIED)		DIMENSION STYLE	SCALE	DESIGN UNITS	THIRD ANGLE PROJECTION	
		mm	INCH	IN/MM	4:1	INCH		
		4 PLACES ±---	±---	DRAWN BY	DATE	TITLE		
		3 PLACES ±---	±---	RPACIFICI	2005/10/11	DUPLX ADAPTER (SC-D/ST, FLANGELESS)		
2 PLACES ±---	±---	CHECKED BY	DATE	APPROVED BY				
1 PLACE ±---	±---	ANGULAR ±1/2°		DATE		MOLEX INCORPORATED		
DRAFT WHERE APPLICABLE MUST REMAIN WITHIN DIMENSIONS		MATERIAL NO.		DOCUMENT NO.		SHEET NO.		
		SEE TABLE		SD-10616X-11X0		1 OF 1		
		THIS DRAWING CONTAINS INFORMATION THAT IS PROPRIETARY TO MOLEX INCORPORATED AND SHOULD NOT BE USED WITHOUT WRITTEN PERMISSION						