





SPECIFICATIONS

CUSTOMER : _____
MODEL NO. : **GFT043IA480272**
VERSION : **F**
DATE : **2023.03.14**
CERTIFICATION : **ROHS**

Customer Sign	Approved By	Prepared By	Prepared By
			

晶發科技股份有限公司
GI FAR TECHNOLOGY CO.,LTD

新北市樹林區東豐街 81 號

No. 81, Dongfeng St, Shulin District, 238034, New Taipei City, Taiwan, R.O.C.
 TEL: +886-2-8684-1188 FAX: +886-2-8684-8532



Revision Record

Data(y/m/d)	Ver.	Description	page
2011.12.12	A	Specification released	
2012.01.03	B	Change Bezel outline and opening size Change Module outline	
2012.12.24	C	Modified a. Typical brightness from 900 cd/m ² to 750 cd/m ² . b. Minimum brightness from 800 cd/m ² to 700 cd/m ² .	6
2013.02.21	D	Modified a. Typical brightness from 750 cd/m ² to 700 cd/m ² . b. Minimum brightness from 700 cd/m ² to 500 cd/m ² .	6
2017.07.28	E	修改公司抬頭、格式統一	
2023.03.14	F	更新公司抬頭認證圖示	



CONTENTS

1. General description
2. Absolute maximum ratings
3. Optical characteristics
4. Block diagram
5. Interface pin connection
6. Electrical characteristics
7. Reliability test items
8. General precaution
9. Outline dimension
10. Package Information

Appendix : Inspection Standard



1. General description

1.1 Introduction

The model is a color active matrix thin film transistor (TFT) liquid crystal display (LCD) that uses amorphous silicon TFT as a switching device. This model is composed of a TFT LCD panel, a driving circuit and a back light system. This TFT LCD has a 4.3 (16:9) inch diagonally measured active display area with WQVGA (480 horizontal by 272 vertical pixel) resolution.

1.2 Features

- 4.3 (16:9 diagonal) inch configuration
- 6 bits + FRC driver with 1channel TTL interface
- LED Backlight
- Up/Down, Left/Right reversion selection
- RoHS Compliance

1.3 Applications

- Mobile NB
- Digital Photo frame
- Multimedia applications and Others AV system

1.4 General information

Item	Specification	Unit
Outline Dimension	105.4 x 67.1 x 2.8 (Typ.)	mm
Display area	95.04(H) x 53.85(V)	mm
Number of Pixel	480 RGB(H) x 272(V)	pixels
Pixel pitch	0.198(H) x 0.198(V)	mm
Pixel arrangement	RGB Vertical stripe	
Display mode	Normally white	
Surface treatment	Antiglare, Hard-Coating(3H) with EWV Pol.	
Weight	45	g
Back-light	Single LED (Side-Light type)	
Power Consumption	B/L System	0.8 w
	Panel Assembly	0.05 w

1.5 Mechanical Information

item		Min.	Typ.	Max.	Unit
Module Size	Horizontal(H)	105.2	105.4	105.6	mm
	Vertical(V)	66.9	67.1	67.3	mm
	Depth(D)	2.5	2.8	3.1	mm



2.0 ABSOLUTE MAXIMUM RATINGS

2.1 Electrical Absolute Rating

2.1.1 TFT LCD Module

Item	Symbol	Min.	Max.	Unit.	Note
Power supply voltage	VDD	-0.3	6.0	V	GND=0
Logic Signal Input Level	Vi	-0.3	VDD+0.3	V	

2.1.2 Back-Light Unit

Item	Symbol	MIN.	TYP.	MAX.	Unit	Note
Forward voltage	Vf	17.8	18.2	18.6	V	(1)(2)
Forward current	If	30	40	50	mA	(1)(2) (3)
Power Consumption	PBL	--	0.8	--	W	

Note: (1) Permanent damage may occur to the LCD module if beyond this specification. Functional operation should be restricted to the conditions described under normal operating conditions.

(2) $T_a = 25 \pm 2^\circ\text{C}$

(3) Test Condition: LED current 40 mA

2.2 Environment Absolute Rating

Item	Symbol	Min.	Max.	Unit	Remarks
Operating Temperature	Topa	-20	+70	$^\circ\text{C}$	
Storage Temperature	Tstg	-30	+80	$^\circ\text{C}$	



3.0 OPTICAL CHARACTERISTICS

3.1 Optical specification:

Item	Symbol	Temp.	Min.	Typ.	Max.	Unit	Condition
Response Time	Tr	25°C	5	7	--	msec	$\theta=0^\circ, \varphi=0^\circ$ (Note 1,3)
	Tf	25°C	20	28	--		
Contrast Rate	Cr	25°C	400	500	--	--	$\theta=0^\circ, \varphi=0^\circ$ LED:ON, LIGHT:OFF(Note1,2)
Brightness	YL	25°C	500	700	--	Cd/m ²	(IL=20mA)(Note1,4)
Visual angle range front and rear	θ	25°C		(θ_U) 40 (θ_D)70		De-gree	$\varphi=0^\circ, CR \geq 10$ LED:ON LIGHT:OFF(Note 1,4)
Visual angle range left and right	θ	25°C		(θ_L) 50 (θ_R) 50		De-gree	$\varphi=90^\circ, CR \geq 10$ LED:ON LIGHT:OFF(Note 1,4)
Brightness uniformity	BUNI			70		%	$\theta=0$ (Note5,7)
Visual angle				6:00			(Note 6)

3.2 Measuring Condition

Measuring surrounding: dark room ,LED current IL : 40mA

Ambient temperature: 25±2°C

15min. warm-up time.

3.3 Measuring Equipment

FPM520 of Westar Display technologies, INC., which utilized SR-3 for Chromaticity and BM-7 for other optical characteristics. Measuring spot size: 20 ~ 21mm



Note (1) Definition of Viewing Angle :

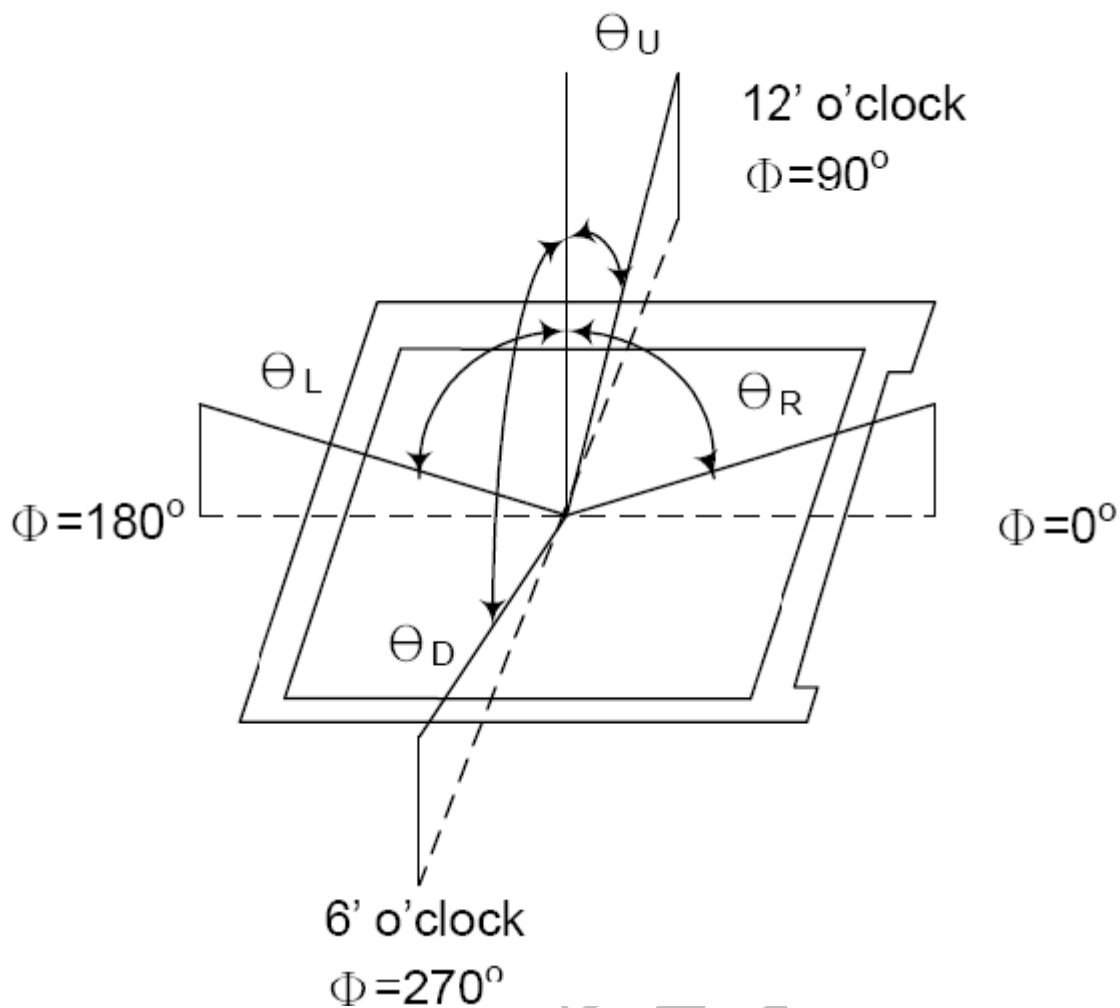

Note (2) Definition of Contrast Ratio (CR):

Measured at the center point of panel

$$CR = \frac{\text{Luminance with all pixels white}}{\text{Luminance with all pixels black}}$$



Note (3) Definition of Response Time: Sum of TR and TF

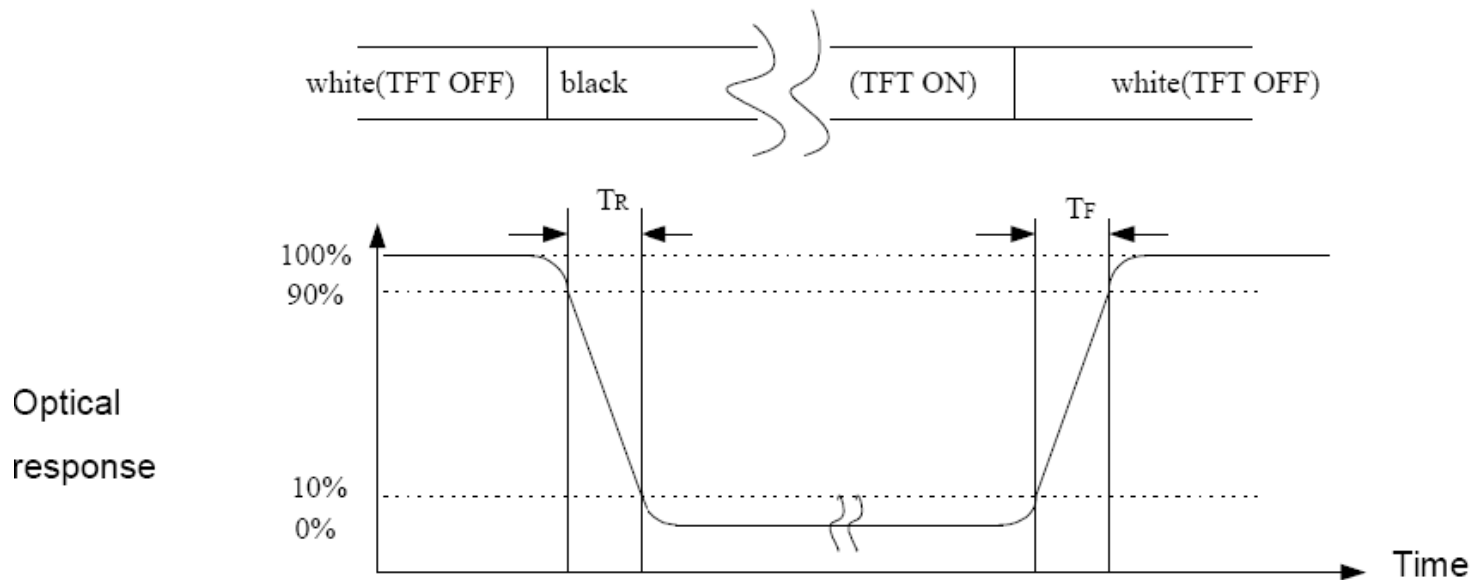

Note (4) Definition of optical measurement setup

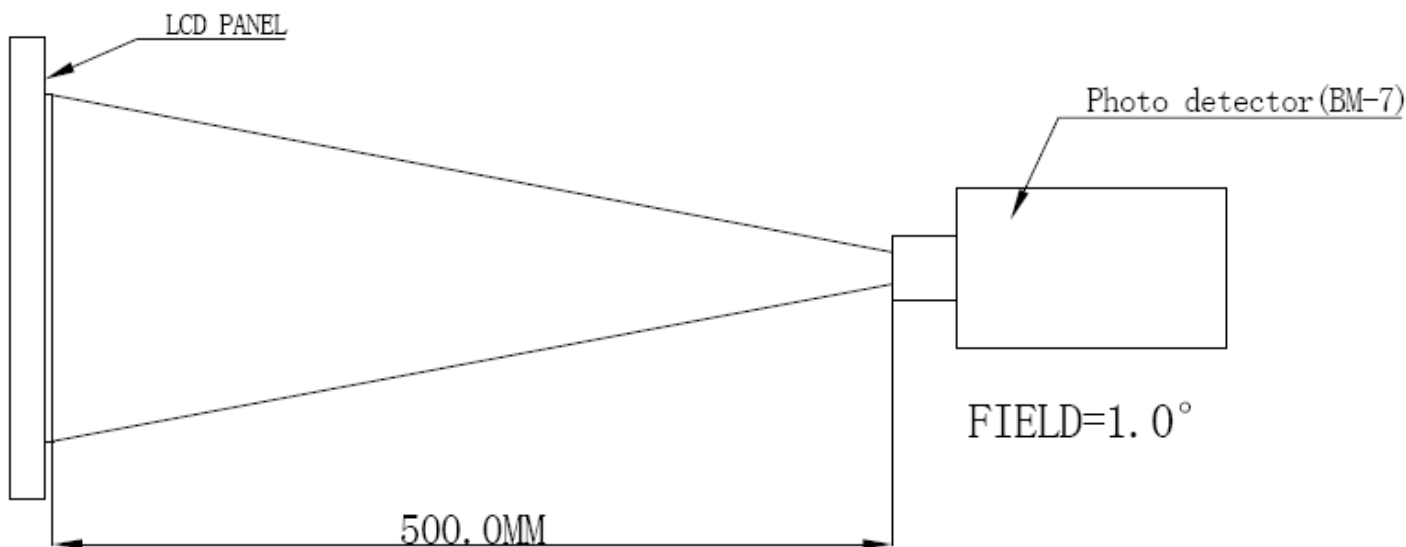



Note (5) Definition of brightness uniformity

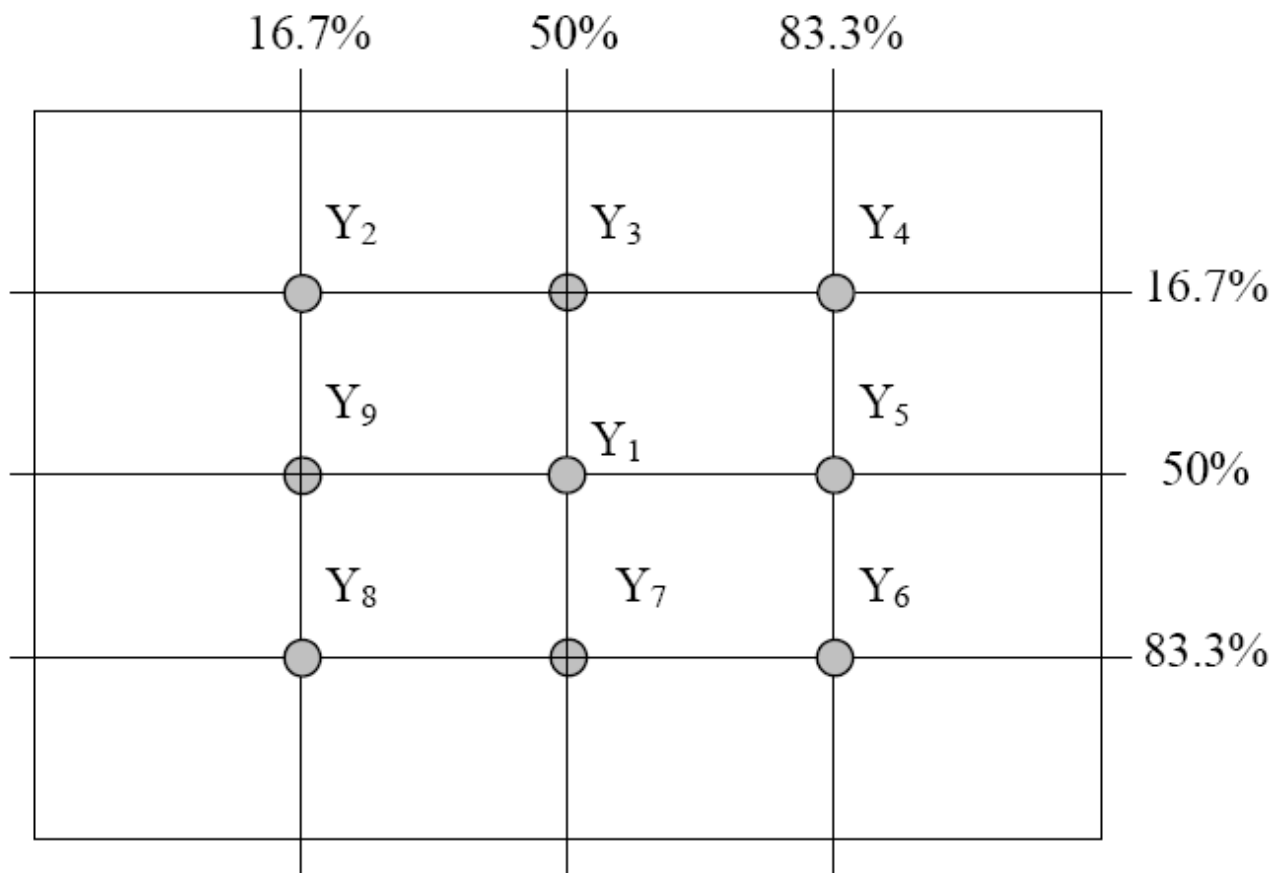

$$\text{Luminance uniformity} = \frac{(\text{Min Luminance of 9 points})}{(\text{Max Luminance of 9 points})} \times 100\%$$

Note (6) Rubbing Direction (The different Rubbing Direction will cause the different optimal view direction).

Note (7) Measured at the brightness of the panel when all terminals of LCD panel are electrically open.



4.0 BLOCK DIAGRAM

4.1 TFT LCD Module

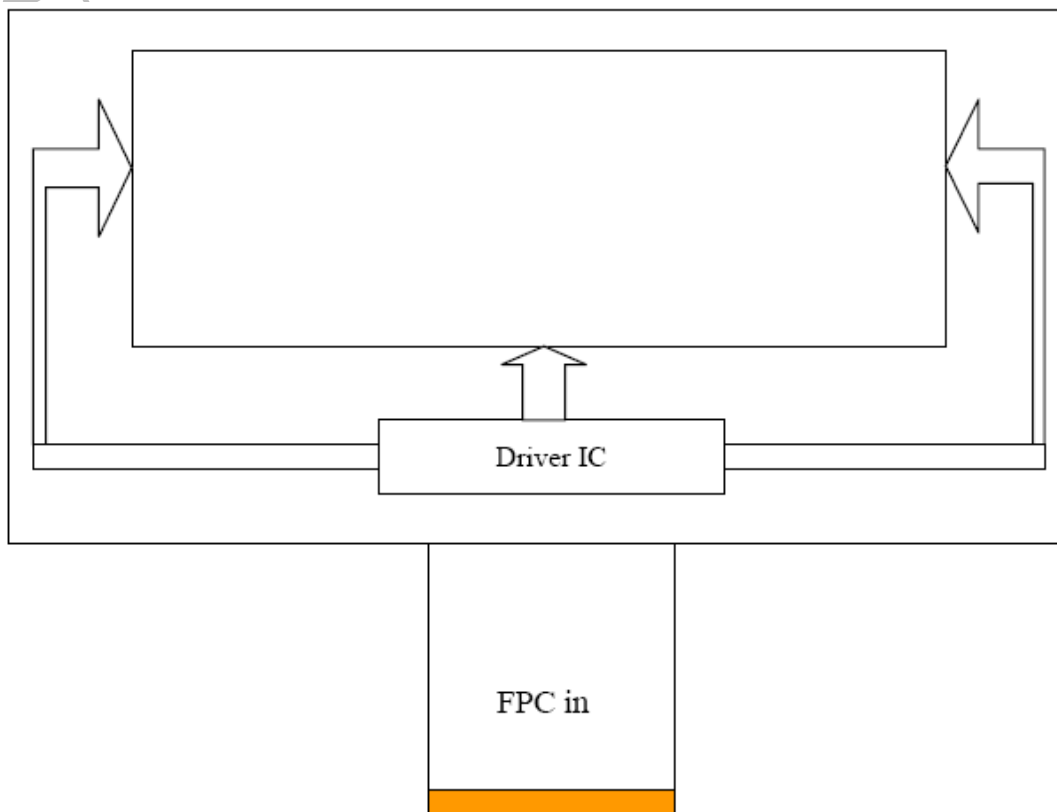

4.2 Pixel Format

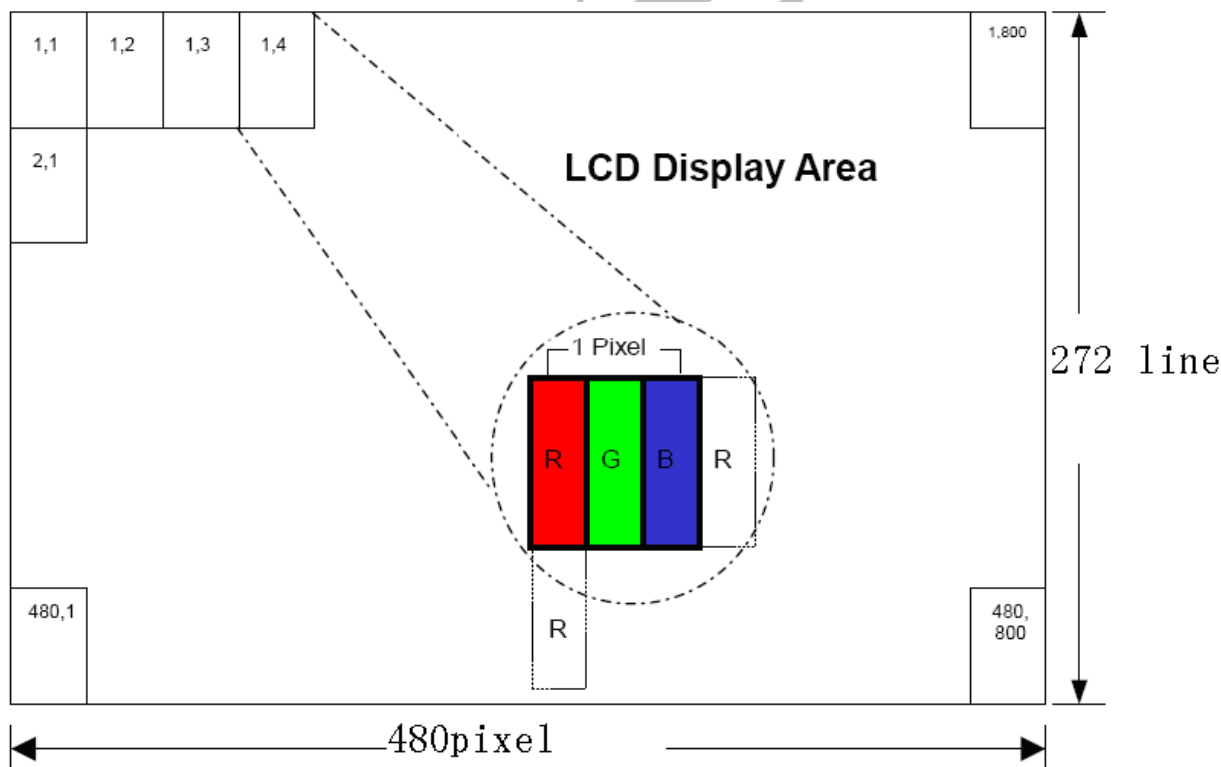



5.0 INTERFACE PIN CONNECTION

5.1 TFT LCD ModuleCN2 (Input signal): FPC Down Connector, (FH28-40S-0.5SH (HIROSE), 40pin, pitch = 0.5mm)

Terminal	Symbol	IO	Functions
1	LEDK	P	Power for LED backlight cathode
2	LEDA	P	Power for LED backlight anode
3	GND	P	Power Ground
4	VDD	P	Power Voltage
5	R0	I	Data Input(LSB)
6	R1	I	Data Input
7	R2	I	Data Input
8	R3	I	Data Input
9	R4	I	Data Input
10	R5	I	Data Input
11	R6	I	Data Input
12	R7	I	Data Input (MSB)
13	G0	I	Data Input (LSB)
14	G1	I	Data Input
15	G2	I	Data Input
16	G3	I	Data Input
17	G4	I	Data Input
18	G5	I	Data Input
19	G6	I	Data Input
20	G7	I	Data Input(MSB)
21	B0	I	Data Input(LSB)
22	B1	I	Data Input
23	B2	I	Data Input
24	B3	I	Data Input
25	B4	I	Data Input
26	B5	I	Data Input
27	B6	I	Data Input
28	B7	I	Data Input(MSB)
29	GND	P	Power Ground
30	DCLK	I	Dot data clock
31	DISP	I	Display on/ off
32	HSYNC	I	Horizontal sync Signal
33	VSYNC	I	Vertical sync signal
34	DE	I	Data Enable



35	NC	--	No Connect
36	GND	P	Power Ground
37	NC	I/O	No Connect
38	NC	I/O	No Connect
39	NC	I/O	No Connect
40	NC	I/O	No Connect

5.2 Back-Light Unit

CN1 LED Power Source (BHSR-02VS-1) or equivalent

Mating Connector: (SBHT-002T-P0.5) or equivalent

Terminal no.	Symbol	Function
1	VL	LED power supply (high voltage)
2	GL	LED power supply (low voltage)



6.0 ELECTRICAL CHARACTERISTICS

6.1 TFT LCD Module

Item	Symbol	Min.	Typ.	Max.	Unit	Note
Power in	VDD	3.0	3.3	3.6	V	2
Input signal voltage	ViH	0.7 VDD	-	VDD	V	1
	ViL	GND		0.3VDD	V	2
Current of power supply	IDD		22		mA	VDD = 3.3V

Note (1): HSYNC, VSYNC, DE, R/G/B Data

Note (2): DGND=AGND=0V

6.2 Back-Light Unit

The backlight system is an edge-lighting type with 12 LED.

The characteristics of the LED are shown in the following tables.

Item	Symbol	Min.	Typ.	Max.	Unit	Note
LED current	IL	30	40	50	mA	(2)
LED Voltage	VL	17.8	18.2	18.6	V	
Operating LED life time	Hr	20000	-	-	Hour	(1)(2)

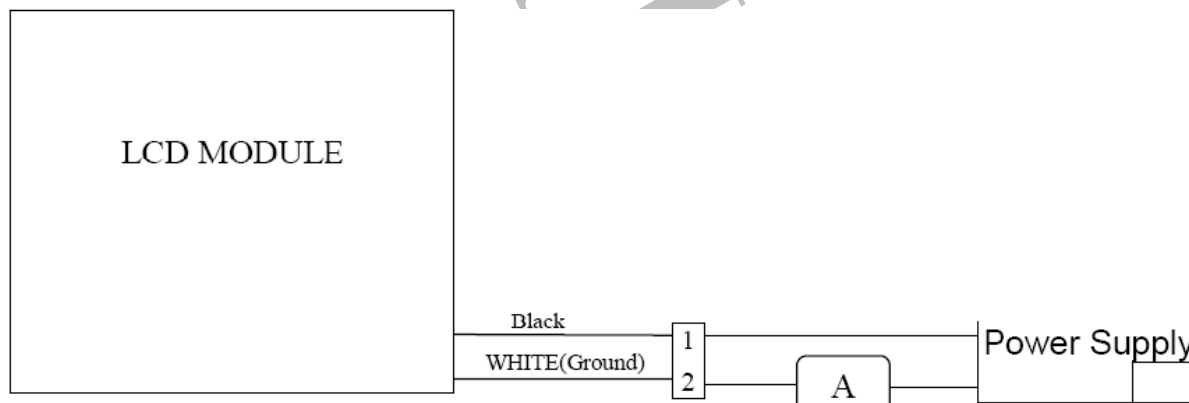

Note (1) LED life time (Hr) can be defined as the time in which it continues to operate under the condition:

$T_a=25\pm 3^{\circ}\text{C}$, typical $I_L=40\text{mA}$ value indicated in the above table until the brightness becomes less than 50%.

Note (2) The “LED life time” is defined as the module brightness decrease to 50% original brightness at $T_a=25^{\circ}\text{C}$ and $I_L=40\text{mA}$. The LED lifetime could be decreased if operating I_L is larger than 40mA. The constant current driving method is suggested.

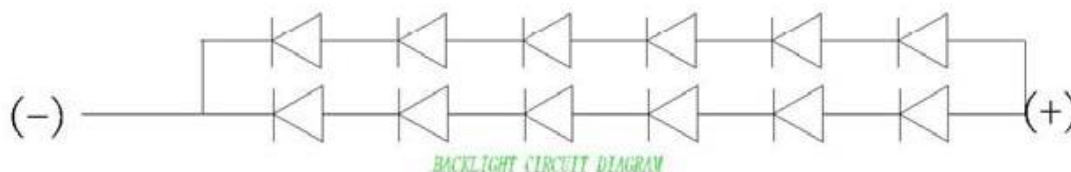



6.3 AC Characteristics

Item	Symbol	Min.	Typ.	Max.	Unit	Note
DCLK clock time	Tclk	83	110	200	ns	DCLK=9MHz
DCLK clock low period	Tcwl	40	-	60	%	
DCLK clock high period	Tcwh	40	-	60	%	
Clock rising time	Trck	9	-	-	ns	
Clock falling time	Tfck	9	-	-	ns	
HSD width	Thwh	1	-	-	DCLK	
HSD period time	Th	55	60	65	us	
HSD setup time	Thsu	12	-	-	ns	
HSD hold time	Thhd	12	-	-	ns	
VSD width	Thwh	1	-	-	Th	
VSD setup time	Tvsu	12	-	-	ns	
VSD hold time	Tvhd	12	-	-	ns	
Data setup time	Tdasu	12	-	-	ns	
Data hold time	Tdahd	12	-	-	ns	
DEN setup time	Tdesu	12	-	-	ns	
DEN hold time	Tdehd	12	-	-	ns	

6.4 Timing Diagram of Interface Signal

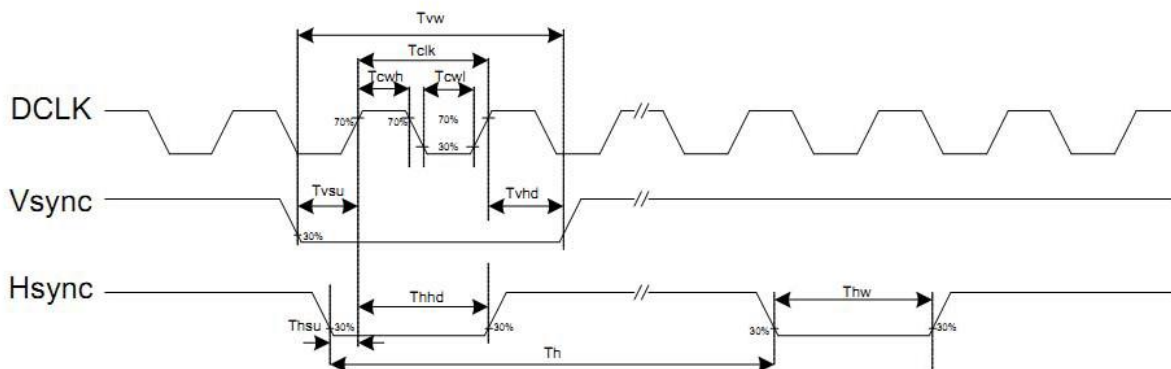
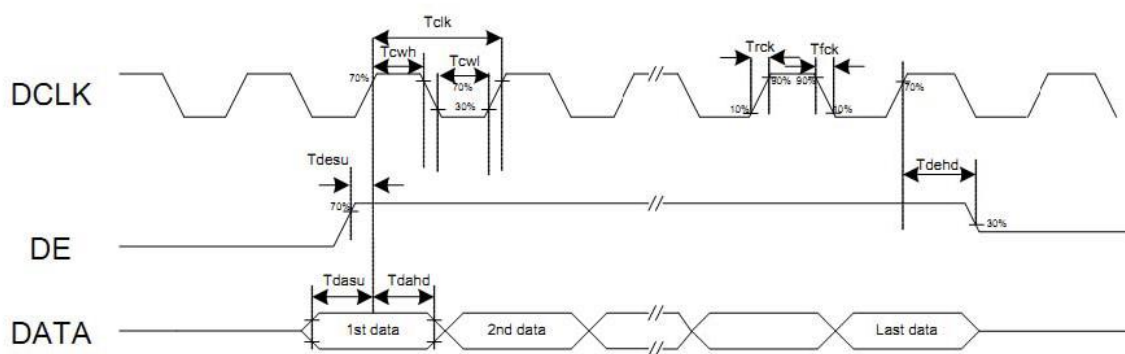

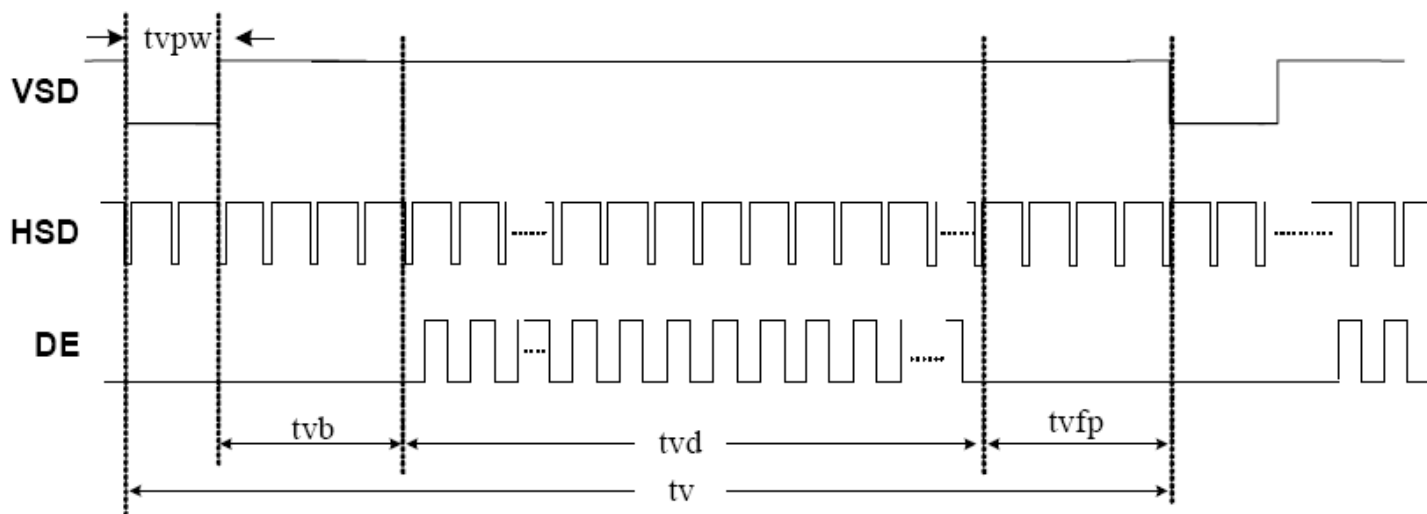

Vertical timing

Item	Symbol	Min.	Typ.	Max.	Unit	Note
DCLK frequency	Fclk	5	9	12	MHz	
VSD period time	Tv	277	288	400	Th	
VSD display area	Tvd	272			Th	
VSD back porch	Tvb	3	8	31	Th	
VSD front porch	Tvfp	2	8	93	Th	
HSD period time	Th	520	525	800	DCLK	
HSD display area	Thd	480			DCLK	
HSD back porch	Thb	36	40	255	DCLK	
HSD front porch	Thfp	4	5	65	DCLK	

6.5 Power Sequence

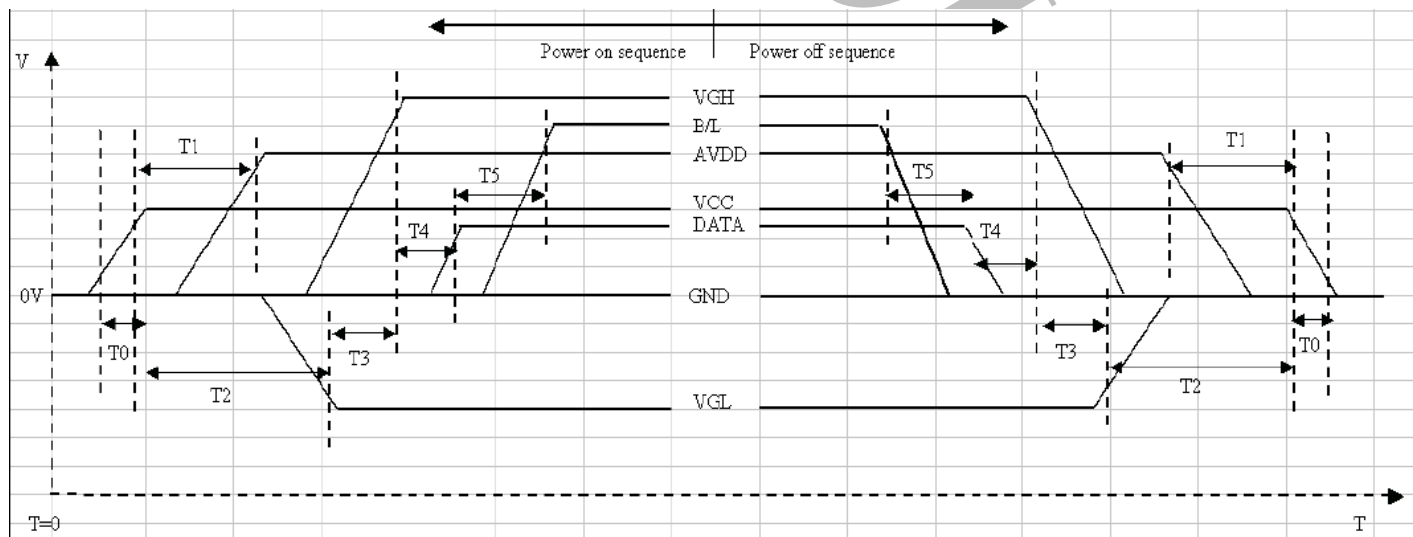



Item	Min.	Typ.	Max.	Unit
T0	0.5	--	20	msec
T1	16			msec
T2	20			msec
T3	10			msec
T4	10		50	msec
T5	50			msec

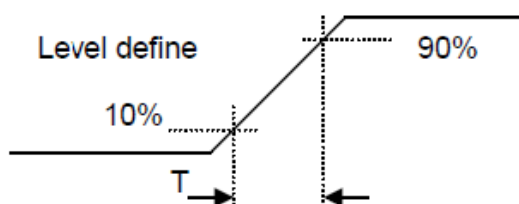

Power On Sequence : VCC=>DATA=>B/L

Power Off Sequence: B/L=>DATA=> VDD

NOTES: Data Include R0~R7,G0~G7,B0~B7,HSD,HSD,VSD,DCLK, DE,DISP



7.0 Reliability test items

Test Item	Test Conditions	Notes
High temperature Operation	70±3°C ,T=120hrs	
Low temperature Operation	-20±3°C ,T=120hrs	
High Temperature Storage	80±3°C ,T=120hrs	1,2
Low Temperature Storage	-30±3°C ,T=120hrs	1,2
Humidity Test	60°C ,Humidity 90% ,120hrs	1,2
Thermal Shock Test	-30°C ,30min~80°C ,30min (200 cycle)	1,2
Vibration Test(Packing)	Sweep frequency 10~55~10HZ/min Amplitude:0.75mm Test direction:X,Y,Z/3 axis Duration 30min/each axis	2
Static Electricity	150Pf 330ohm ±8KV, 10time air discharge ±4KV, 10time connect discharge	



8.0 GENERAL PRECAUTION

8.1 Use Restriction

This product is not authorized for use in life supporting systems, aircraft navigation control systems, military systems and any other application where performance failure could be life threatening or otherwise catastrophic.

8.2 Disassembling or Modification

Do not disassemble or modify the module. It may damage sensitive parts inside LCD module, and may cause scratches or dust on the display. GIFAR does not warrant the module, if customers disassemble or modify the module.

8.3 Breakage of LCD Panel

- 8.3.1. If LCD panel is broken and liquid crystal spills out, do not ingest or inhale liquid crystal, and do not contact liquid crystal with skin.
- 8.3.2. If liquid crystal contacts mouth or eyes, rinse out with water immediately.
- 8.3.3. If liquid crystal contacts skin or cloths, wash it off immediately with alcohol and rinse thoroughly with water.
- 8.3.4. Handle carefully with chips of glass that may cause injury, when the glass is broken.

8.4 Electric Shock

- 8.4.1. Disconnect power supply before handling LCD module.
- 8.4.2. Do not pull or fold the LED cable.
- 8.4.3. Do not touch the parts inside LCD modules and the fluorescent LED's connector or cables in order to prevent electric shock.

8.5 Absolute Maximum Ratings and Power Protection Circuit

- 8.5.1. Do not exceed the absolute maximum rating values, such as the supply voltage variation, input voltage variation, variation in parts' parameters, environmental temperature, etc., otherwise LCD module may be damaged.
- 8.5.2. Please do not leave LCD module in the environment of high humidity and high temperature for a long time.
- 8.5.3. It's recommended to employ protection circuit for power supply.

8.6 Operation

- 8.6.1 Do not touch, push or rub the polarizer with anything harder than HB pencil lead.
- 8.6.2 Use fingerstalls of soft gloves in order to keep clean display quality, when persons handle the LCD module for incoming inspection or assembly.
- 8.6.3 When the surface is dusty, please wipe gently with absorbent cotton or other soft material.
- 8.6.4 Wipe off saliva or water drops as soon as possible. If saliva or water drops contact with polarizer for a long time, they may causes deformation or color fading.
- 8.6.5 When cleaning the adhesives, please use absorbent cotton wetted with a little petroleum benzine or other adequate solvent.



8.7 Mechanism

Please mount LCD module by using mouting holes arranged in four corners tightly.

8.8 Static Electricity

8.8.1 Protection film must remove very slowly from the surface of LCD module to prevent from electrostatic occurrence.

8.8.2. Because LCD module use CMOS-IC on circuit board and TFT-LCD panel, it is very weak to electrostatic discharge. Please be careful with electrostatic discharge. Persons who handle the module should be grounded through adequate methods.

8.9 Strong Light Exposure

The module shall not be exposed under strong light such as direct sunlight. Otherwise, display characteristics may be changed.

8.10 Disposal

When disposing LCD module, obey the local environmental regulations.



9. Outline dimension

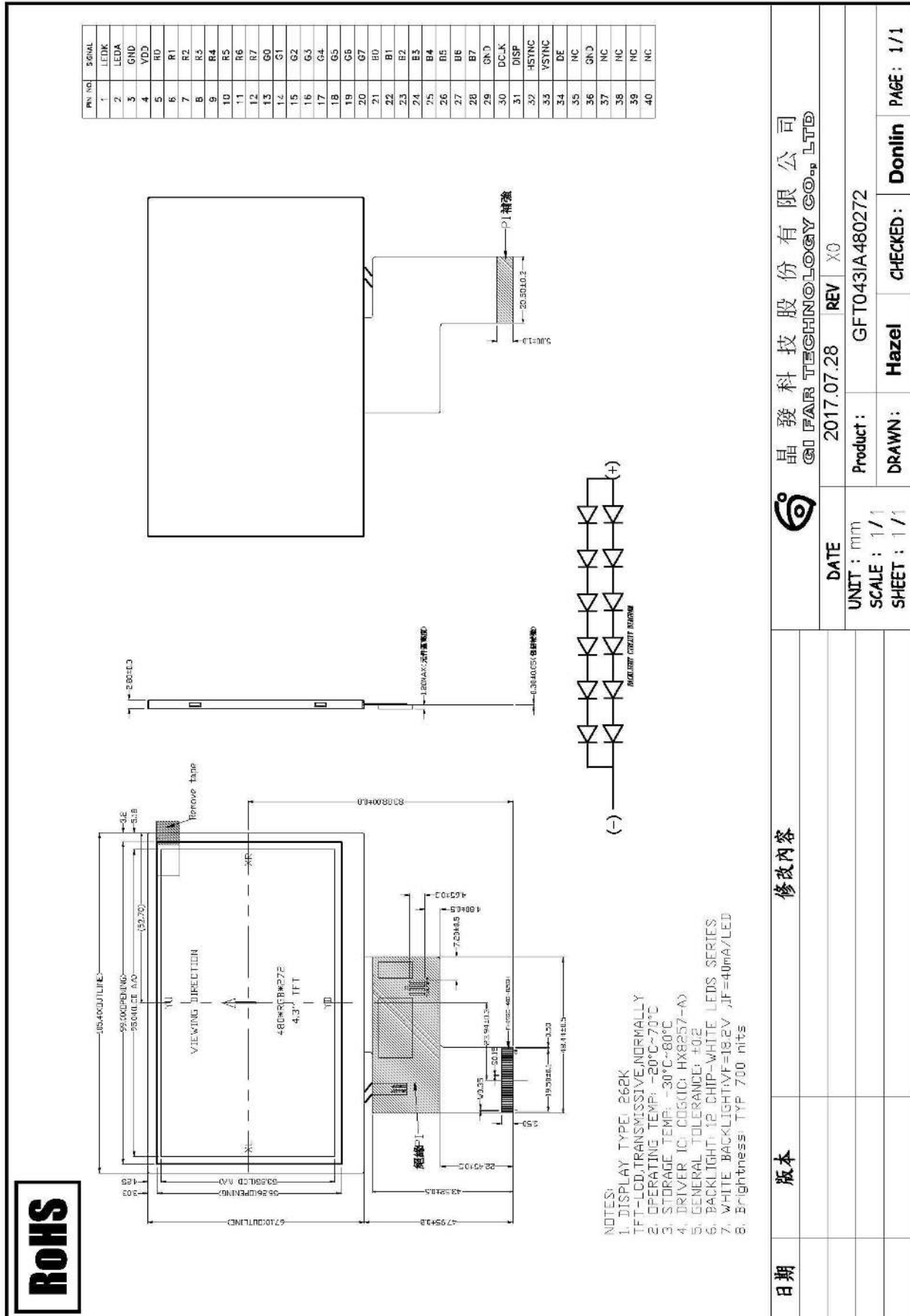

晶發科技股份有限公司
GI FAR TECHNOLOGY CO., LTD

DATE: 2017.07.28 REV: X0
 UNIT: mm Product: GFT043IA480272
 SCALE: 1/1 DRAWN: Hazel
 SHEET: 1/1 CHECKED: Donlin PAGE: 1/1



10. PACKAGE INFORMATION

1	1 Tray	:	6 pcs (modules)
2	1 stack	:	10 tray +1 Cover tray
3	1 Carton	:	(1 Cover tray + 10 tray) 3 stack
4	Total pcs	:	1 Carton (6pcs * 10tray * 3 stack) = 18 pcs
5	Carton size = NO. 17	:	495*315*435mm
6	Net weight	:	TBD KG
7	Gross weight	:	TBD KG

** Packaging information **

- 1 Tray = 6 pcs



- 1 stack=10 tray+1 Cover tray



**Each layer of tray should be staggered stacked



WW

- 1 Carton = 3 stack, Total pcs = 180 pcs

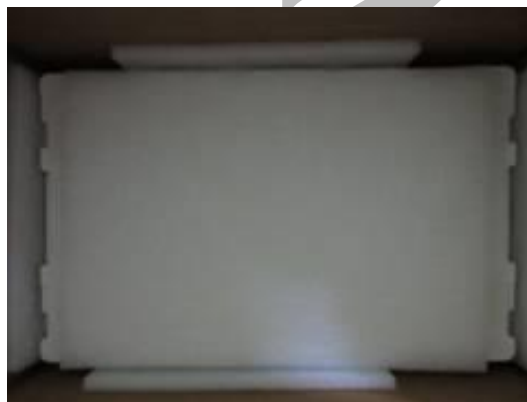

出貨檢驗標準書
Shipping inspection standard

核准 Approved by	審核 Checked by	作成 Made by
ANDY	JACKY	RUBY

1.目的 Purpose :

規範出貨產品之檢驗項目及判斷標準，確保產品出貨能滿足客戶要求。

Standardize the inspection items and judgment standards to ensure the products that shipped out can meet customer's requirements.

2.範圍 Area :

適用於出廠之所有產品。

Applicable to all products shipped from the factory.

3.名詞解釋 Explanation of terms :

3-1 主要缺陷：亦會造成功能缺失或嚴重外觀缺陷。

Major Defects: It also causes loss of function or serious appearance defects.

3-2 次要缺陷：稍有缺陷但不影響客戶使用。

Minor defect: Slightly defective but does not affect customer use.

4.檢驗體制 Inspection system :

4-1 抽樣計劃：依 ANSI/ASQ Z1.4 一般檢驗水準 II 之 正常檢驗一次抽驗方案。

Sampling plan: According to ANSI/ASQ Z1.4 general inspection level II the normal inspection one-time sampling plan.

4-2 允收水準 Acceptable Level : (AQL)

主要缺陷 Major defect : 0.4 %

次要缺陷 Minor defect : 0.65 %

5.檢驗條件 Inspection conditions :

5-1 使用相關之檢測儀器及測試、量測工具。

Use relevant testing instrument, testing and measuring tools .

5-2 環境要求：其條件需控制在常溫下 $23^{\circ}\text{C}\pm 3^{\circ}\text{C}$ 及溼度 70%RH 以下。

Environmental requirements: The conditions should be controlled at room temperature $23^{\circ}\text{C}\pm 3^{\circ}\text{C}$ and humidity below 70%RH.

5-3 外觀檢驗：須在 $380\pm 20\%$ LUX 的白色日光燈下，其目視距離需於產品離 30 ± 5 cm 檢驗。

Appearance inspection: Under the white fluorescent lamp of $380\pm 20\%$ LUX , the visual distance shall be checked above the product 30 ± 5 cm.

5-4 電性測試 Electrical Testing :

5-4-1 有背光之產品需關燈並在 $5\sim 300\text{Lux}\pm 3\%$ 下檢驗。

The products with backlight should be tested at $5\sim 300\pm 3\%$ Lux.

5-4-2 無背光之產品需開燈並在 $60\sim 300\text{Lux}\pm 3\%$ 白色日光燈下檢驗。

Products without backlight need to be turned on and tested under $60\sim 300 \pm 3\%$ LUX white fluorescent lamps .

5-5 檢查視角依產品視角方向。

Check the viewing angle according to the product viewing angle.

5-6 其不良現象檢視區域 Bad phenomenon View area

5-6-1 適用種類 Applicable category : COB、TFT

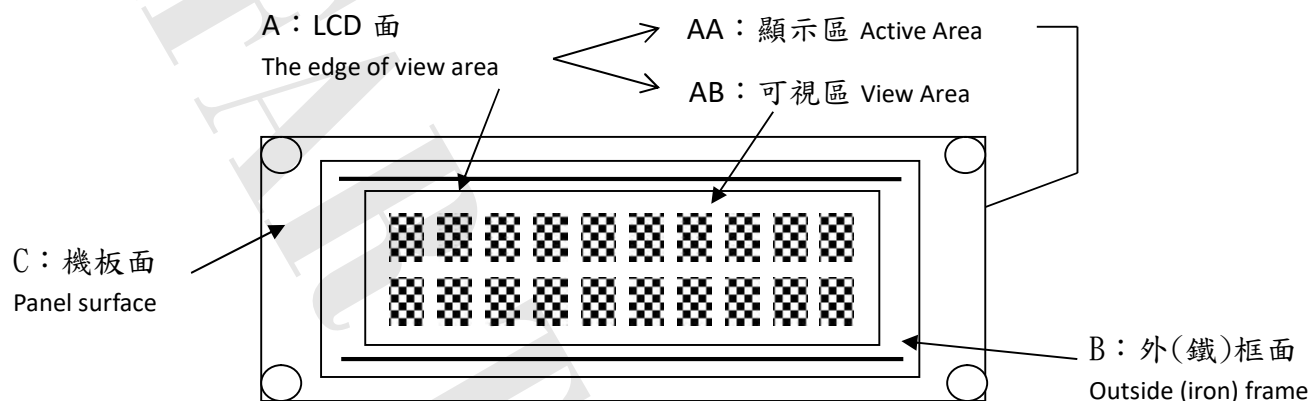

5-6-2 適用種類 Applicable category : COG、TAB、TN

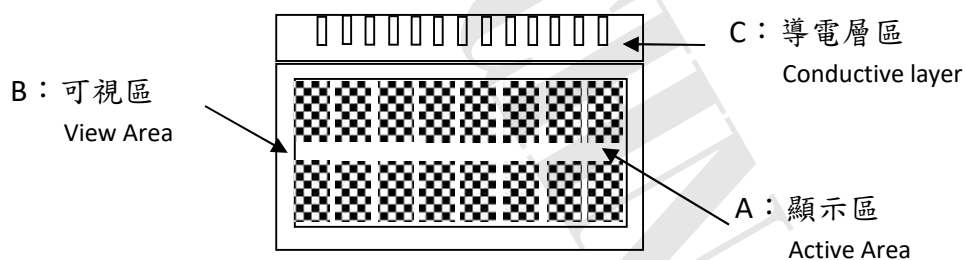

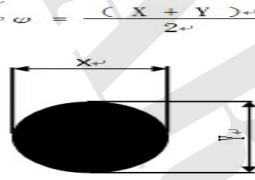
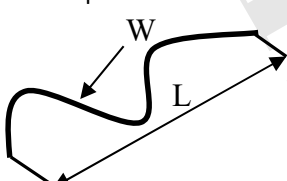
種類 Category		TFT																
編號 No.	檢驗項目 Item	檢驗內容及判定標準 Inspection Content & Standard	區域 Zone	類別 Category	缺陷等級 Level													
1	點類(一) Dot (1)	氣泡...圓狀 Bubble ...round shape 	兩點距離須超過 5 mm Two points have to be ≥ 5 mm <table border="1"> <tr> <th>ϕ (mm)</th> <th>允收數 Acceptance Qty</th> </tr> <tr> <td>$\phi \leq 0.25$</td> <td>無視 Ignore</td> </tr> <tr> <td>$0.25 < \phi \leq 0.5$</td> <td>3</td> </tr> <tr> <td>$\phi > 0.5$</td> <td>0</td> </tr> </table>	ϕ (mm)	允收數 Acceptance Qty	$\phi \leq 0.25$	無視 Ignore	$0.25 < \phi \leq 0.5$	3	$\phi > 0.5$	0	A	外觀 Appearance	次要 Minor AQL0.65%				
ϕ (mm)	允收數 Acceptance Qty																	
$\phi \leq 0.25$	無視 Ignore																	
$0.25 < \phi \leq 0.5$	3																	
$\phi > 0.5$	0																	
2	線類 Line	刮傷、毛屑...等線狀 Scratch、Fiber.. and other linear shape. 	<table border="1"> <tr> <th>L (mm)</th> <th>W (mm)</th> <th>允收數 Acceptance Qty</th> </tr> <tr> <td>--</td> <td>$W \leq 0.01$</td> <td>無視 Ignore</td> </tr> <tr> <td>$L \leq 3$</td> <td>$0.01 < W \leq 0.05$</td> <td>3</td> </tr> <tr> <td>$L > 3$</td> <td>$W > 0.05$</td> <td>0</td> </tr> </table>	L (mm)	W (mm)	允收數 Acceptance Qty	--	$W \leq 0.01$	無視 Ignore	$L \leq 3$	$0.01 < W \leq 0.05$	3	$L > 3$	$W > 0.05$	0	A	外觀 Appearance	次要 Minor AQL0.65%
L (mm)	W (mm)	允收數 Acceptance Qty																
--	$W \leq 0.01$	無視 Ignore																
$L \leq 3$	$0.01 < W \leq 0.05$	3																
$L > 3$	$W > 0.05$	0																
3	FPC 外觀 FPC Appearance	※ FPC 上刺傷導致線路無法導通 拒收 Stabbing on the FPC causes the line to fail to conduct Reject ※ FPC 上髒污或是殘留異物以致線路無法導通 拒收 Dirty or residual foreign matter on the FPC makes the circuit unable to conduct Reject ※ FPC 直角折痕、斷裂 拒收 FPC right-angle crease and fracture Reject	C	外觀 Appearance	次要 Minor AQL0.65%													
4	點類(二) Dot (2)	<table border="1"> <tr> <th>類型 Type</th> <th>允收數 Acceptance Qty</th> </tr> <tr> <td>亮點 Highlights</td> <td>$N \leq 2$</td> </tr> <tr> <td>暗點 dark spot</td> <td>$N \leq 3$</td> </tr> </table> ※ 缺陷點面積暫全點 1/2 則為一個缺陷點 Temporarily full area of defect point 1/2 is a defect point ※ 亮點：於黑畫面中使用 2% ND Filter 遮蓋須不可見 Highlights: Use 2% ND Filter in a black screen to cover up invisible ※ 暗點：在純紅、綠、藍模式下判定 Dark spot: judged in pure red, green and blue mode	類型 Type	允收數 Acceptance Qty	亮點 Highlights	$N \leq 2$	暗點 dark spot	$N \leq 3$	AA	電訊 Electronics	次要 Minor AQL0.65%							
類型 Type	允收數 Acceptance Qty																	
亮點 Highlights	$N \leq 2$																	
暗點 dark spot	$N \leq 3$																	

5	無動作 No reaction	顯示畫面一直處於起始畫面而無法進行切換 拒收 The display (view area) always shows in the initial screen and can't be switched to others. Reject	AA	電訊 Electronics	主要 Major AQL 0.4%
6	無畫面 No display	通電後，完全無任何畫面顯示 拒收 After connecting to the power, there is no display. Reject	AA	電訊 Electronics	主要 Major AQL 0.4%
7	斷線 Broken line	顯示畫面中少直、橫線 拒收 There is a lack of vertical or horizontal lines in the view area. Reject	AA	電訊 Electronics	主要 Major AQL 0.4%
8	I CON	顯示畫面缺少部份顯示圖案 拒收 Lack of partial ICON in the view area. Reject	AA	電訊 Electronics	主要 Major AQL 0.4%
9	深淺不一 Color difference	顯示畫面的對比，比其他顯示深或淺並依電氣規格(VOP)值判定 The contrast of display is obviously lighter or darker than others and according to the VOP value in the electronics specification. 拒收或與客端簽訂限度樣 Reject or inspect according to the golden sample	AA	電訊 Electronics	次要 Minor AQL0.65%
10	畫面異常 Abnormal screen	通電後畫面出現未定義之電訊不良現象 拒收 After connecting to the power, there is a undefined electronics appearance showing in the view area. Reject	AA	電訊 Electronics	主要 Major AQL 0.4%
11	牛頓環 Newton ring	點亮後目視有環、圓或曲線狀 拒收 There are rings, circles or curves visually after lighting Reject	A	電訊 Electronics	次要 Minor AQL0.65%
12	背光色不均 Uneven color of backlight	※ 點亮後 LED 有明暗不均現象依其均勻度判定 拒收 After lighting LEDs have brightness and darkness uneven the determined according to its uniformity. Reject ※ 點亮後 LED 色澤不一致 拒收 LED color is inconsistent after lighting Reject	A	電訊 Electronics	次要 Minor AQL0.65%
13	亮度不足 Lack of brightness	波長、色座標、輝度與圖面標示定義不符 拒收 Wave length, chromatic coordinates, brightness don't correspond to the definition of the drawing. Reject	A	電訊 Electronics	主要 Major AQL 0.4%

TFT

14	觸控 Touch	測試時無法點觸或劃，其靈敏度判定則依 SPEC 上定義判定 拒收 It cannot be touched or swiped during the test. Its sensitivity is judged according to the definition on SPEC Reject	A	電訊 Electronics	主要 Major AQL 0.4%
15	尺寸量測 Size Measurement	未依圖面上標示 拒收 No correspond to the indication on the drawing. Reject	ALL	外觀 Appearance	主要 Major AQL 0.4%
16	其他 Other	如發現有上述未定義之不良則與客端簽訂限度樣 If there is another undefined defective situation. It will be listed as others. The inspection standard is according to the golden sample.	ALL	電訊 Electronics 外觀 Appearance	次要 Minor AQL0.65%