



iCE40 Ultra™ Breakout Board

User Guide

Introduction

Thank you for choosing the Lattice iCE40 Ultra™ Breakout Board.

This guide describes how to begin using the iCE40 Ultra Breakout Board, an easy-to-use platform for demonstrating the high-current LED drive capabilities of the iCE40 Ultra FPGA. Along with the evaluation board and accessories, this kit includes the pre-loaded LED Driver Demo that demonstrates driving the RGB LEDs with a PWM circuit. In addition, most of the device's I/O balls are accessible via one of the several header locations on the board, facilitating rapid prototyping of user functions.

The contents of this user's guide include demo operation, top-level functional descriptions of the various portions of the evaluation board, descriptions of the on-board connectors, shunts, a complete set of schematics and the bill of materials for the iCE40 Ultra Breakout Board.

Note: Static electricity can severely shorten the lifespan of electronic components. Be careful when handling the iCE40 Ultra Breakout Board as to not damage it from ESD.

Features

The iCE40 Ultra Breakout Board includes:

- **iCE40 Ultra Breakout Board** – The iCE40 Ultra Breakout Board features the following on-board components and circuits:
 - iCE40 Ultra (iCE5LP4K-SWG36) device in a 36-ball WLCSP package.
 - Example of a board using this 0.35-pitch WLCSP package.
 - High-current LED output
 - Infrared transmit
 - iCE40 Ultra Current Measurements
 - Standard USB cable for device programming
 - RoHS-compliant packaging and process
- **Pre-loaded Demo** – The kit includes a pre-loaded demo to control the onboard RGB LED in conjunction with a software run GUI.
- **USB Connector Cable** – A mini B USB port provides power, a programming interface and communication for the software RGB LED GUI to the iCE40 Ultra SPI port.

Figure 1 shows the top side of the iCE40 Ultra Breakout Board indicating the specific features that are designed on the board.

Figure 1. iCE40 Ultra Breakout Board (Top Side)

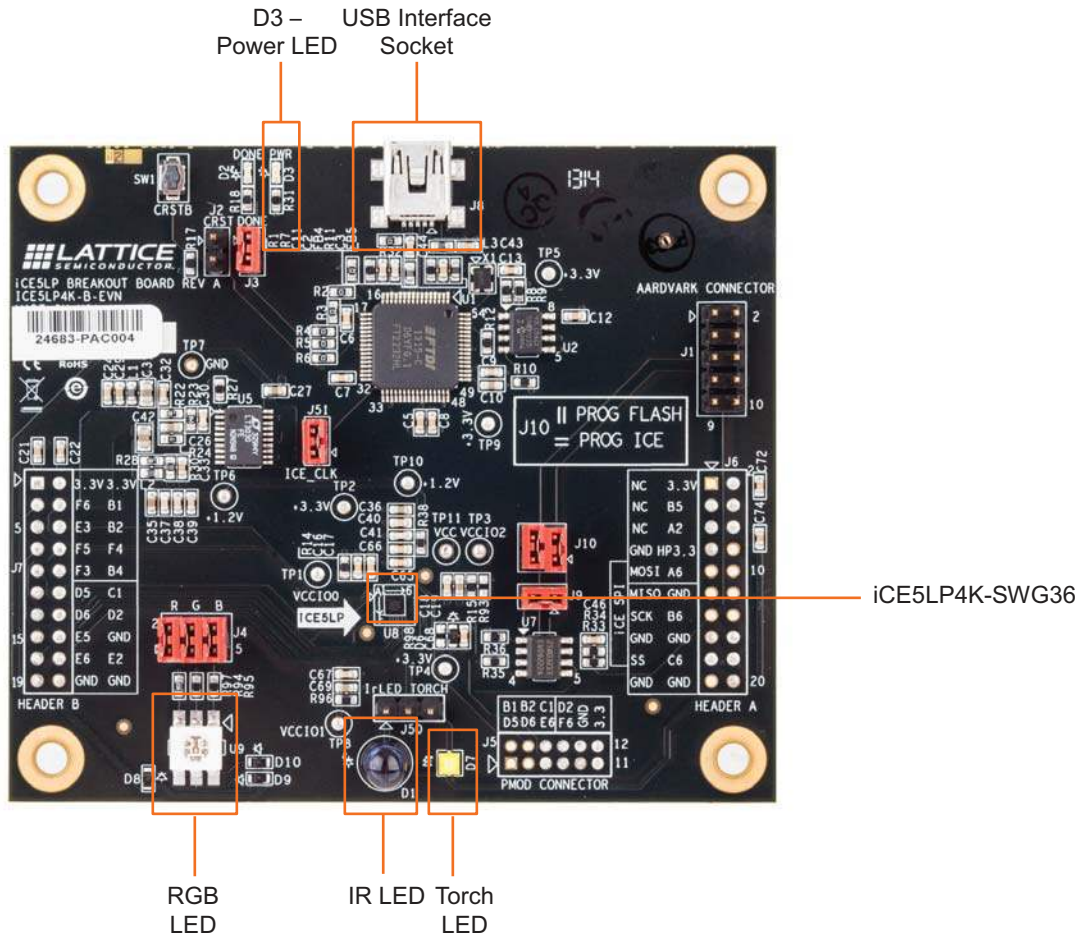

iCE40 Ultra Device

The board features an iCE5LP4K FPGA with a 1.2 V core supply. The device is packaged in a 36-ball WLCSP. For a complete description of this device, see DS1048, [iCE40 Ultra Family Data Sheet](#).

Software Requirements

You should install the following software before you begin developing designs for the board:

- Lattice iCEcube2 2014.04 (or higher)
- Diamond Programmer 3.2 (or higher)

These software are available at the Lattice website [Design Software & IP](#) page. Make sure you log in to www.lattice-semi.com, otherwise these software downloads will not be visible. It is also recommended to download the RGB LED software GUI which interfaces with the iCE40 Ultra Breakout Board. This GUI allows you to control the RGB LED for color, brightness, blinking and breathing. Download the PC or MAC version of the GUI at www.lattice-semi.com.

Demonstration Design Shunts

Lattice provides the RGB LED Driver Demo design programmed in the board. The RGB LED Driver Demo used in conjunction with the software GUI illustrates the use of a PWM driver controlling the LEDs on the board. Below is a description of the control jumpers for each LED.

- The RGB LED will transition colors
 - J4 can be used to probe RGB LED (Default shunted). If you remove J4, the RGB LED will not light up.
- The IR LED is controlled when a shunt is placed across J50 pins 1-2
- The Bar Code LED is controlled when a shunt is placed across J29 pins 2-3 (Default shunted)

Figure 2 shows the default board shunt locations.

Figure 2. Default Shunt Locations

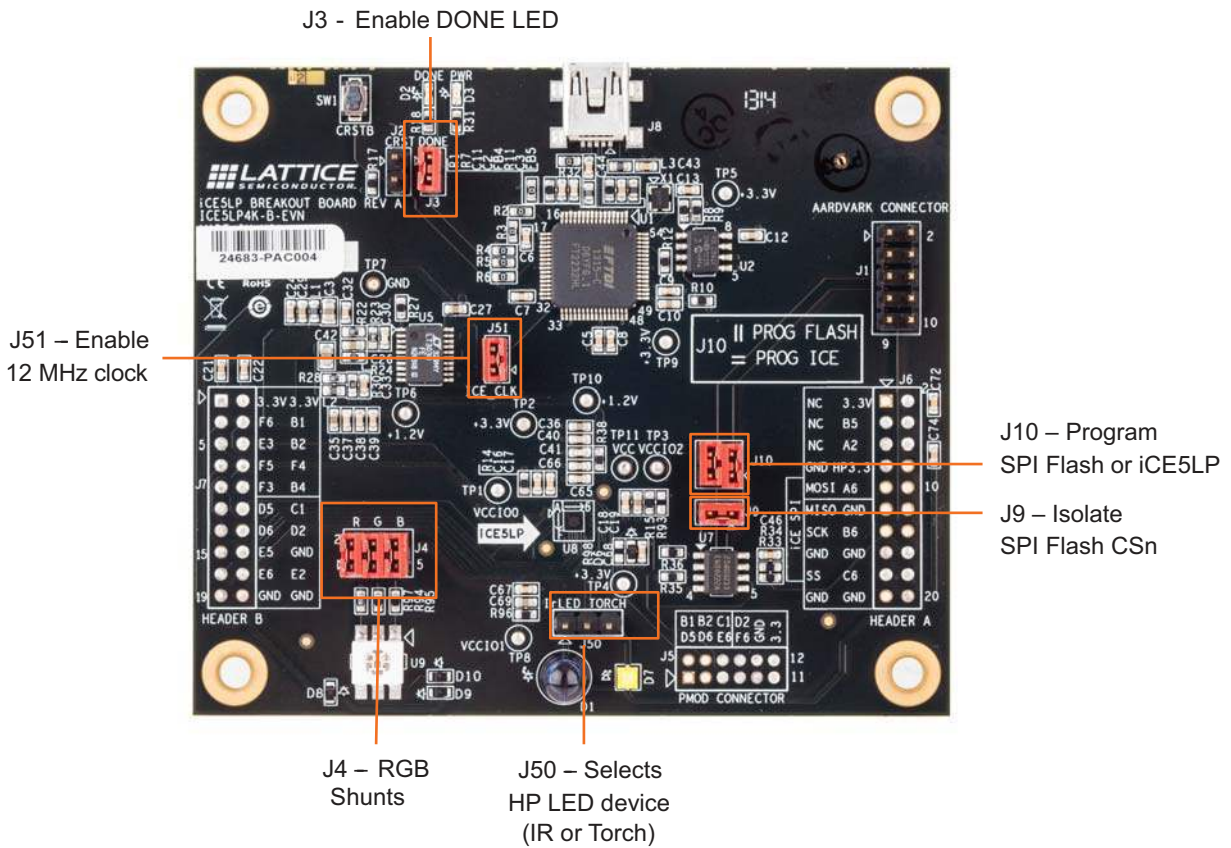

Clock Sources

The board has a single 12 MHz clock source. The 12 MHz clock drives both the FTDI USB interface device, and the iCE5LP4K device. The iCE5LP4K can be disconnected from the 12 MHz oscillator using J51. This is necessary, for example, when iCE40 Ultra device ball C2 is mistakenly programmed as an output and prevents the FTDI USB interface from operating.

Board Power

The board provides the following power features:

- Board Power
 - Board power is derived from the USB connection.
 - D3 Green LED indicates Board Power
- iCE40 Ultra VCC
 - Onboard 1.2 V supply
 - ICC can be measured across the series resistor R38 (1 Ohm) at TP10 and TP11
- iCE40 Ultra VCCIO
 - Onboard 3.3 V supply
 - ICC0 can be measured across the series resistor R14 (1Ohm) at TP1 and TP2
 - ICC1 can be measured across the series resistor R96 (1Ohm) at TP8 and TP9
 - ICC2 can be measured across the series resistor R15 (1Ohm) at TP3 and TP4

The power supplies on the iCE40 Ultra Breakout Board are simplified and suitable for booting from the external SPI flash. The power supply sequencing does not conform to the NVCM boot requirements as specified in DS1048, [iCE40 Ultra Family Data Sheet](#). The user may encounter intermittent boot success and/or higher than specified startup currents when attempting to boot from NVCM.

Board Configuration and Programming

The board allows for programming of the iCE40 Ultra or the SPI Flash:

- SPI Flash Programming J10 shunt pins 1-3 and 2-4 (Default shunted)
 - U7 Micron Technology Inc part number N25Q032A13ESC40F
- iCE40 Ultra Configuration or Programming J10 shunt pins 1-2 and 3-4
 - U8 iCE5LP4K-SWG36
- CRESETB can be asserted by pushing SW1
 - Can be probed with J2
- Done LED D2
 - Can be probed with J3 (Default shunted)

Details of the iCE40 Ultra Board for use in programming are shown in Figure 3.

Figure 3. Configuration and Programming Details

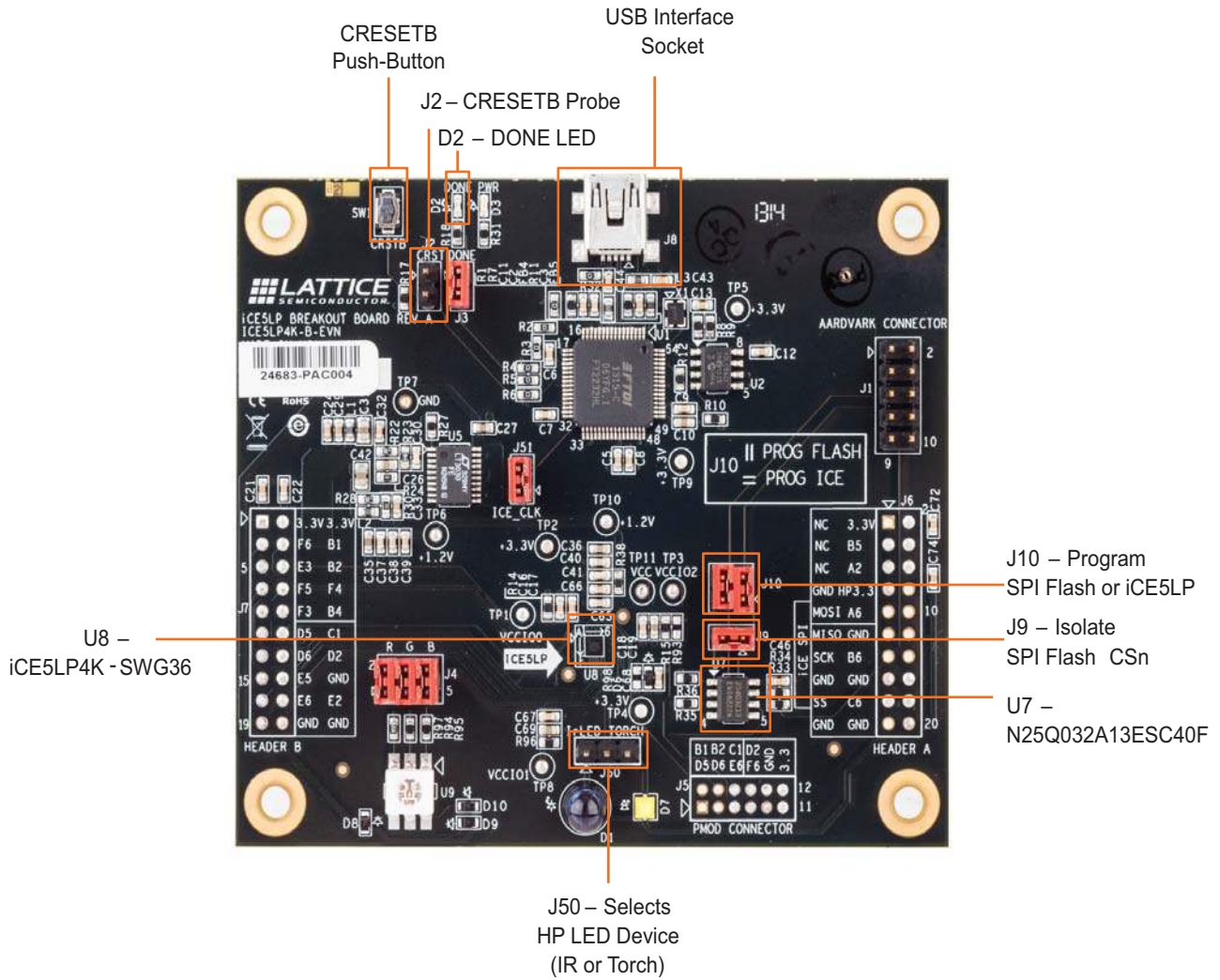

Test Points

The board features a number of headers and test connections which provide access to the iCE40 Ultra I/Os:

Figure 4. J6 Header 'A' Breakouts

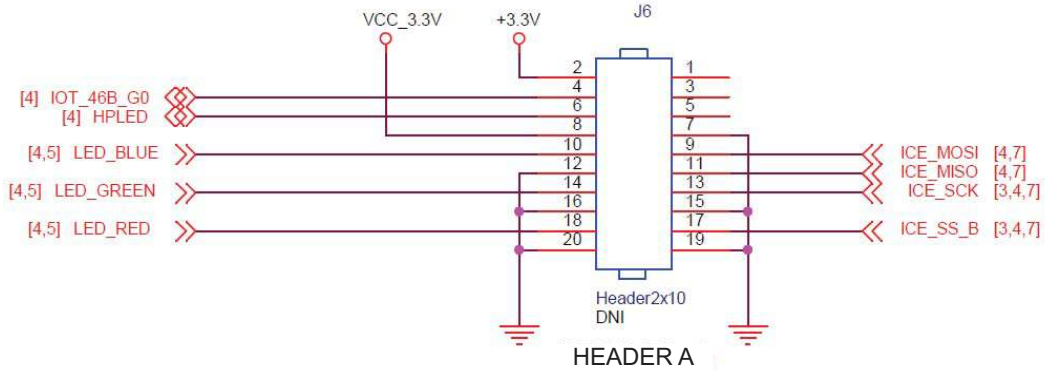

Figure 5. J7 Header 'B' Breakouts

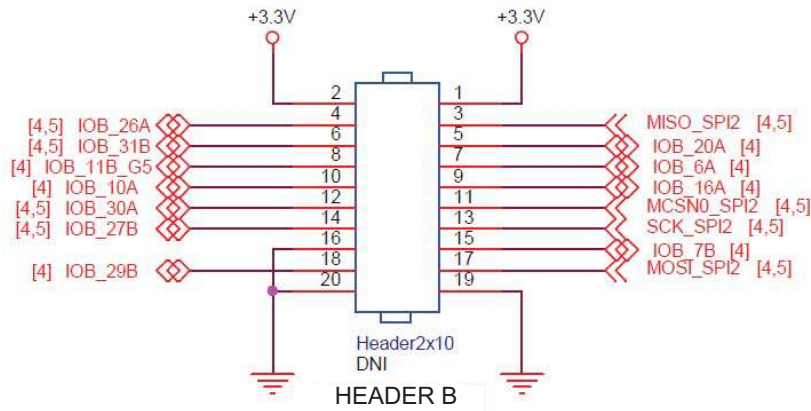

Figure 6. J5 PMOD Connector

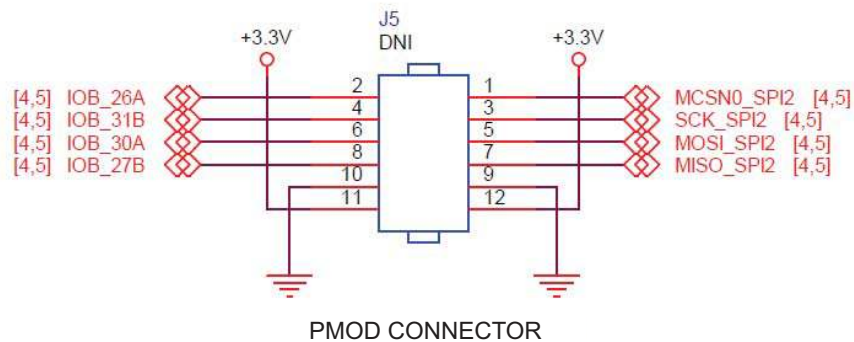
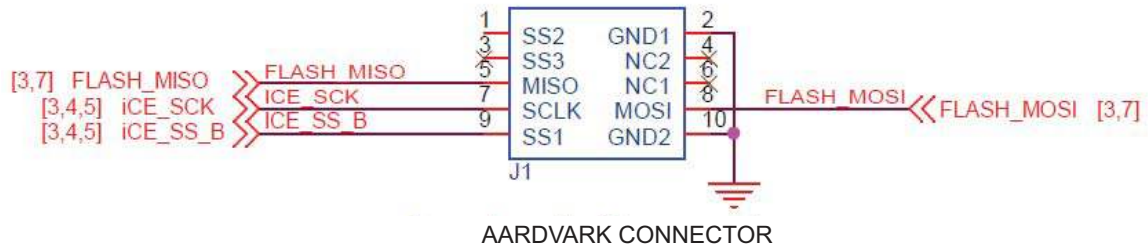
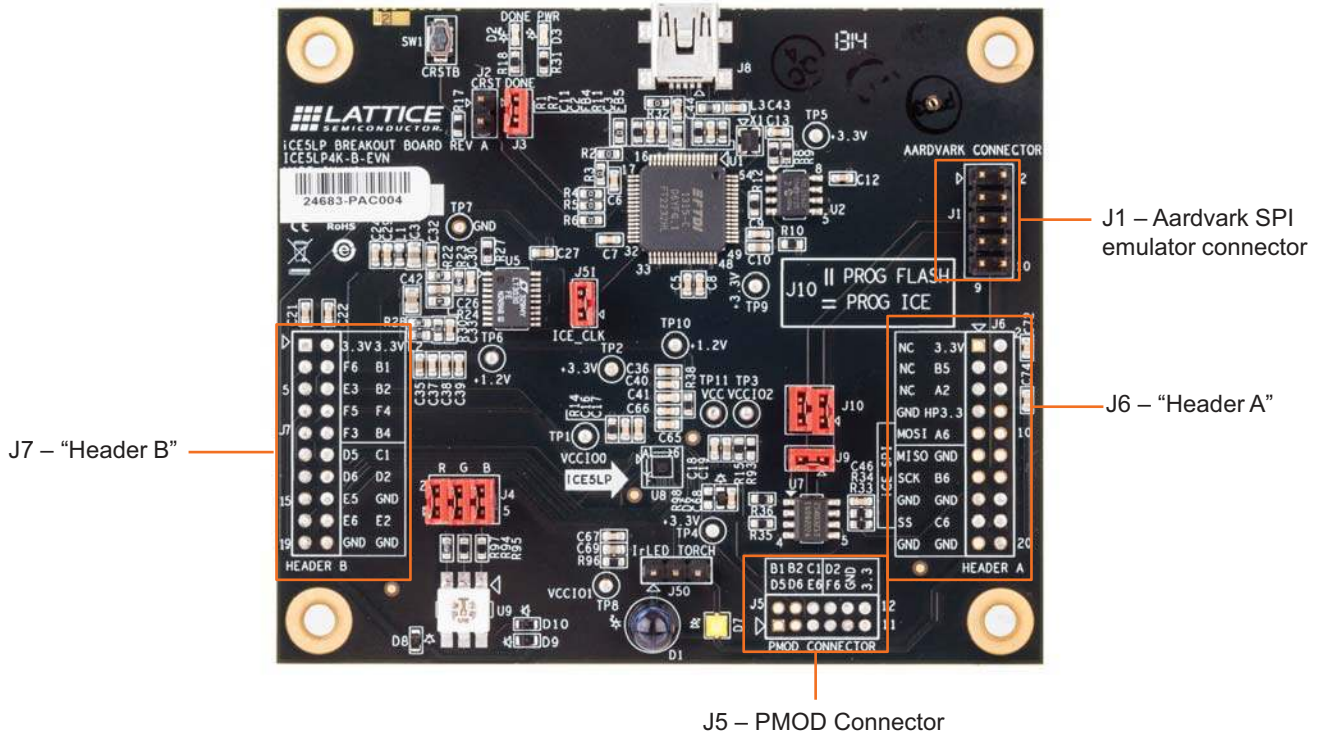

Figure 7. J7 Header 'B' Breakouts



The break-out headers and test connectors are shown in Figure 8.

Figure 8. Breakout Headers



RGB LED Demonstration Design and Software GUI

The iCE40 Ultra Breakout Board can demonstrate a complete controller for an RGB LED. These are the steps necessary to run the demonstration.

1. Ensure that the RGB LED GUI is installed.
2. Make sure the jumpers on J10 are both in the vertical position. This is the default pins 1-3 and 2-4 shorted together.

Figure 9. SPI Flash Selection (Vertical) for J10

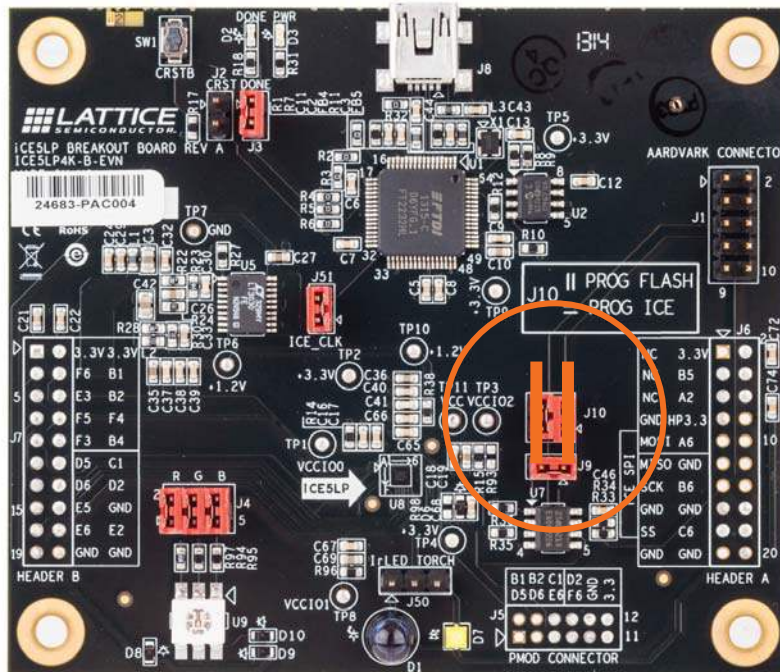

3. Connect the iCE40 Ultra breakout board via the USB cable to a PC or MAC.

- After the iCE40 Ultra device has initialized and the RGB LED is illuminated RED, change the J10 jumper positions to horizontal, shorting pins 1-2 and 3-4. This is required to allow the USB port to communicate with the iCE40 Ultra device.

Figure 10. iCE Selection (Horizontal) for J10

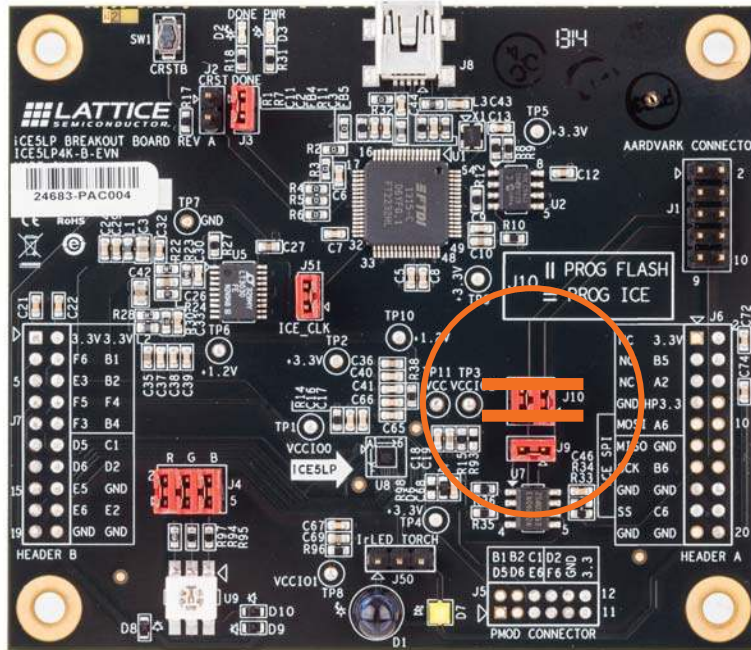

- Start the RBG GUI on the PC or MAC.

Figure 11. iCE40 Ultra LED Demonstration Interface

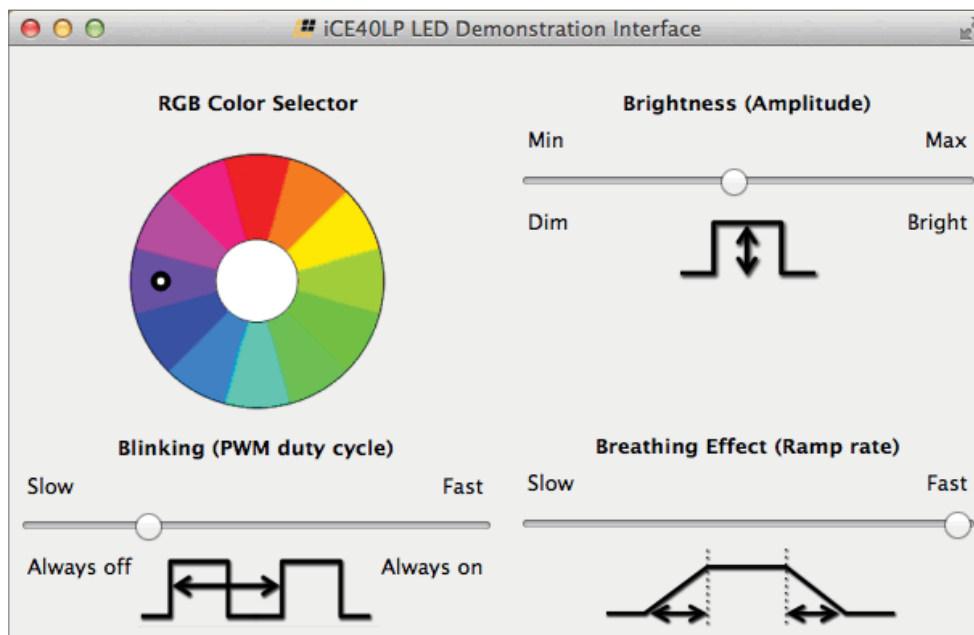

Now you can control the RGB LED on the iCE40 Ultra Breakout Board. You can set the color, brightness, blinking rate as well as breathing.

GUI Serial Communication Interface

LED Control via SPI

The Software GUI demonstration program communicates with the iCE40 Ultra device using a SPI serial communication channel. The SPI interface (mode 0) control link is implemented using a simple write-only protocol (see Figure 12).

Figure 12. SPI Physical Transaction

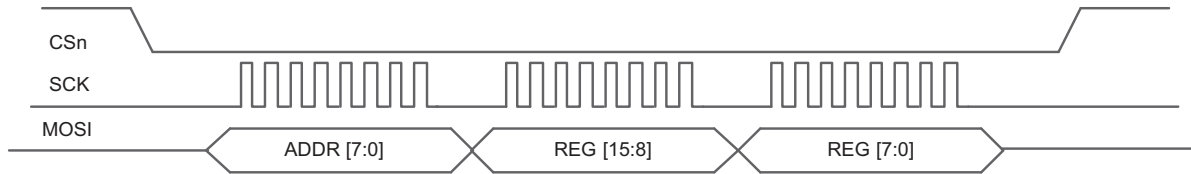

SPI Protocol

Data on the MOSI serial line is transmitted MSB first.

Addr[7:0] – Controls which of the 16 bits are updated with REG data.

Note: Unspecified REG bits must be written, but are ignored.

Addr	Bits Written	Bit Position
0x13	REG[3:0]	-----dddd
0x14	REG[7:4]	-----cccc----
0x15	REG[11:8]	----bbbb-----
0x16	REG[15:12]	aaaa-----
0x19	REG[15:0]	aaaabbbbccccdddd

REG[15:0] – Consists of four control fields.

Field	Bit Positions	Function
aaaa	REG[15:12]	RGB Color[3:0]
bbbb	REG[11:8]	Brightness[3:0]
cccc	REG[7:4]	Breathe Ramp [3:0]
dddd	REG[3:0]	Blink Rate [3:0]

Register Definitions

Default setting (hardware, software) is denoted by (*).

RGB Color[3:0]	Color	Color Code
0000*	Red	#FF0000
0001	Orange	#FF7F00
0010	Yellow	#FFFF00
0011	Chartreuse	#7FFF00
0100	Green	#00FF00
0101	Spring Green	#00FF7F
0110	Cyan	#00FFFF
0111	Azure	#007FFF
1000	Blue	#0000FF
1001	Violet	#7F00FF
1010	Magenta	#FF00FF
1011	Rose	#FF007F
1100	—	
1101	—	
1110	—	
1111	White	#FFFFFF

Brightness[3:0]	Level (%)
0000	6.25(dim)
0001	12.5
0010	18.75
0011	25
0100	31.25
0101	37.5
0110	43.75
0111*	50
1000	56.25
1001	62.5
1010	68.75
1011	75
1100	81.25
1101	87.5
1110	93.75
1111	100 (bright)

Breathe Ramp [3:0]	Factor
0000*	.0x (fast)
0001	.063x
0010	.125x
0011	.25x
0100	.5x
0101	1x
0110	2x
0111	4x (slow)
1000	—
1001	—
1010	—
1011	—
1100	—
1101	—
1110	—
1111	—

Blink Rate [3:0]	Off Time (s) ¹
0000	Always On
0001	1/16 (fast)
0010	1/8
0011	1/4
0100	1/2
0101*	1
0110	2
0111	4
1000	Always Off
1001	—
1010	—
1011	—
1100	—
1101	—
1110	—
1111	—

1. By default the LED "On-Time" is fixed at approximately one second. If desired, the design may be modified so that "On-Time" is symmetrical to the "Off-Time". To do so, replace the file "LED_control.v" with "LED_control_sym.v" and rebuild the design using the iCEcube2 software.

Ordering Information

Description	Ordering Part Number	China RoHS Environment-Friendly Use Period (EFUP)
iCE40 Ultra Breakout Board	ICE5LP4K-B-EVN	

Technical Support Assistance

e-mail: techsupport@latticesemi.com

Internet: www.latticesemi.com

Revision History

Date	Version	Change Summary
December 2014	1.1	Updated Board Power section. Added power-supply sequence clarification note.
June 2014	01.0	Initial release.

© 2014 Lattice Semiconductor Corp. All Lattice trademarks, registered trademarks, patents, and disclaimers are as listed at www.latticesemi.com/legal. All other brand or product names are trademarks or registered trademarks of their respective holders. The specifications and information herein are subject to change without notice.

Appendix A. Schematic Diagrams

Figure 13. Block Diagram

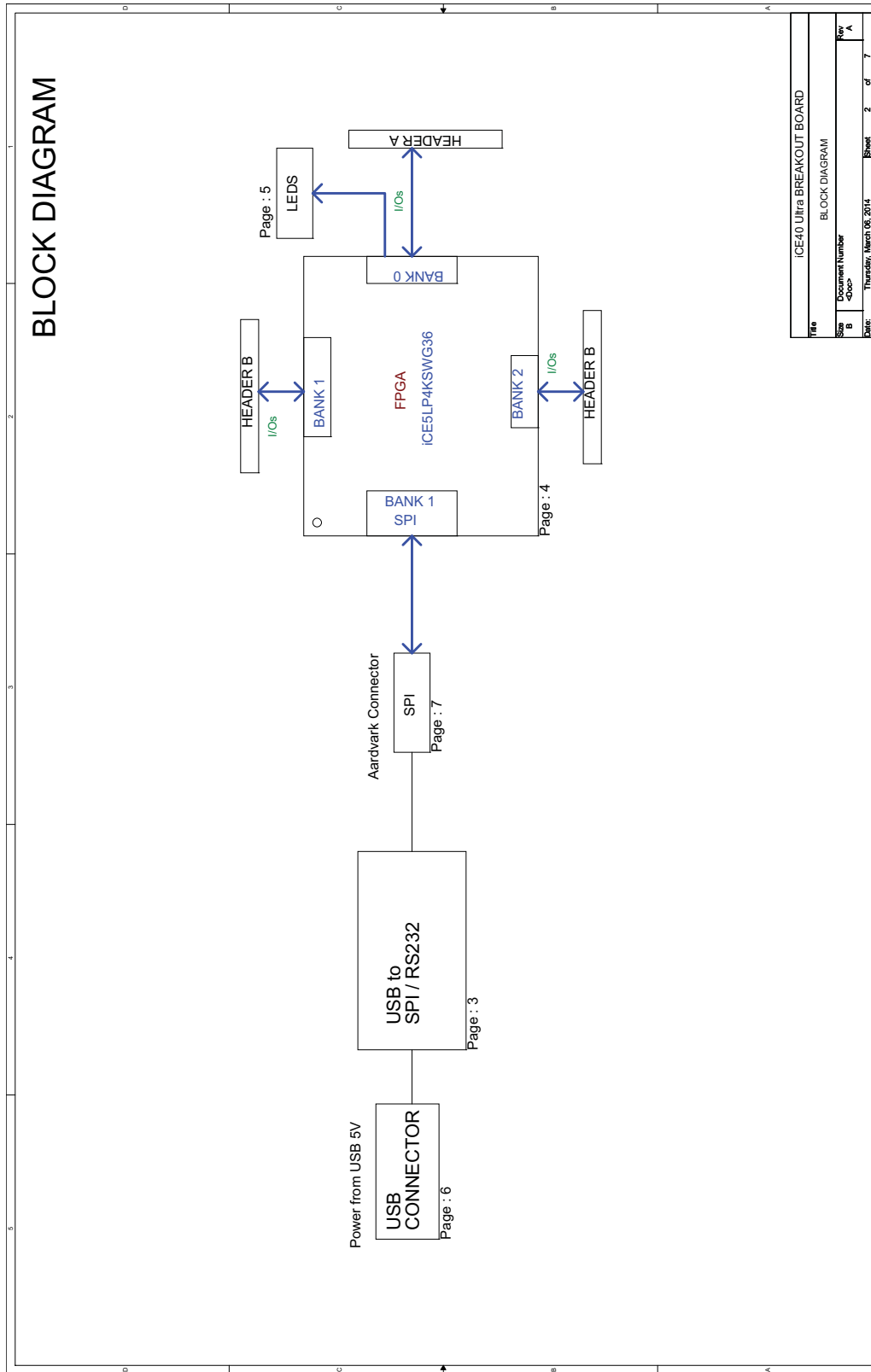
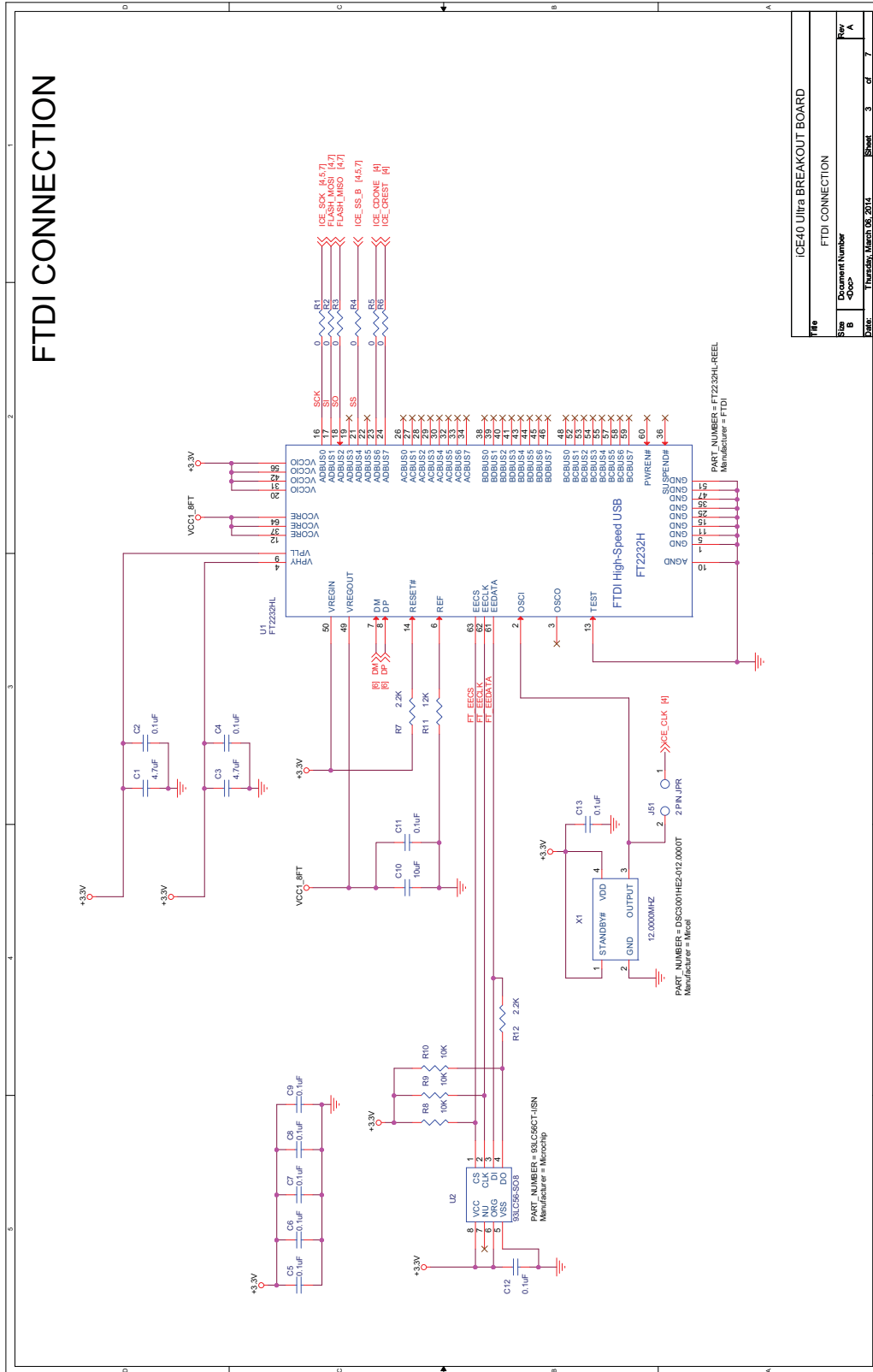

Figure 14. FTDI Connection



File		ICE40 Ultra BREAKOUT BOARD	
Step	Document Number	Sheet	Rev
B	<Doc>	3	A
Date:	Thursday, March 06, 2014		

Figure 15. DUT Connection

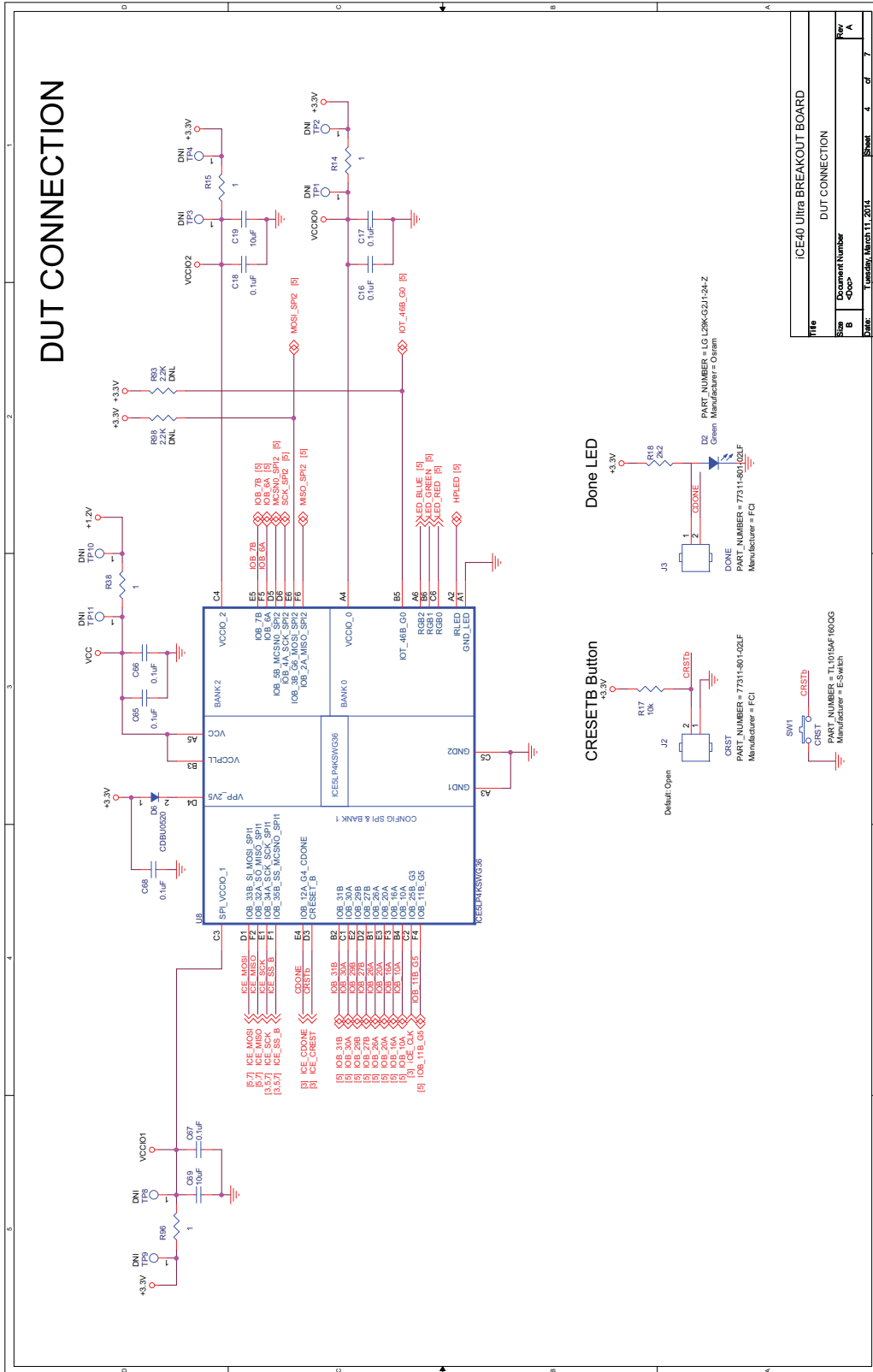

Figure 16. LEDs and Headers

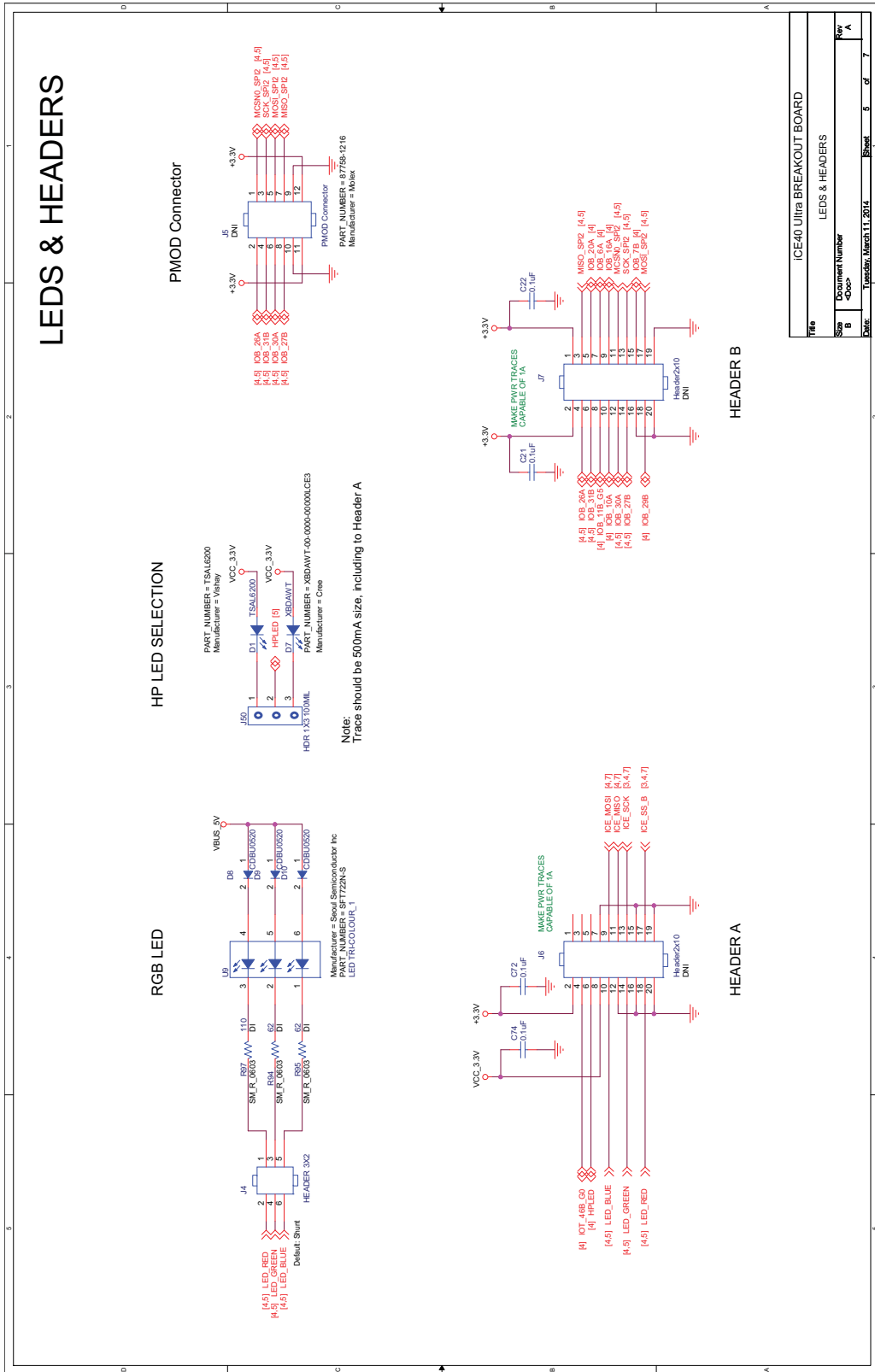
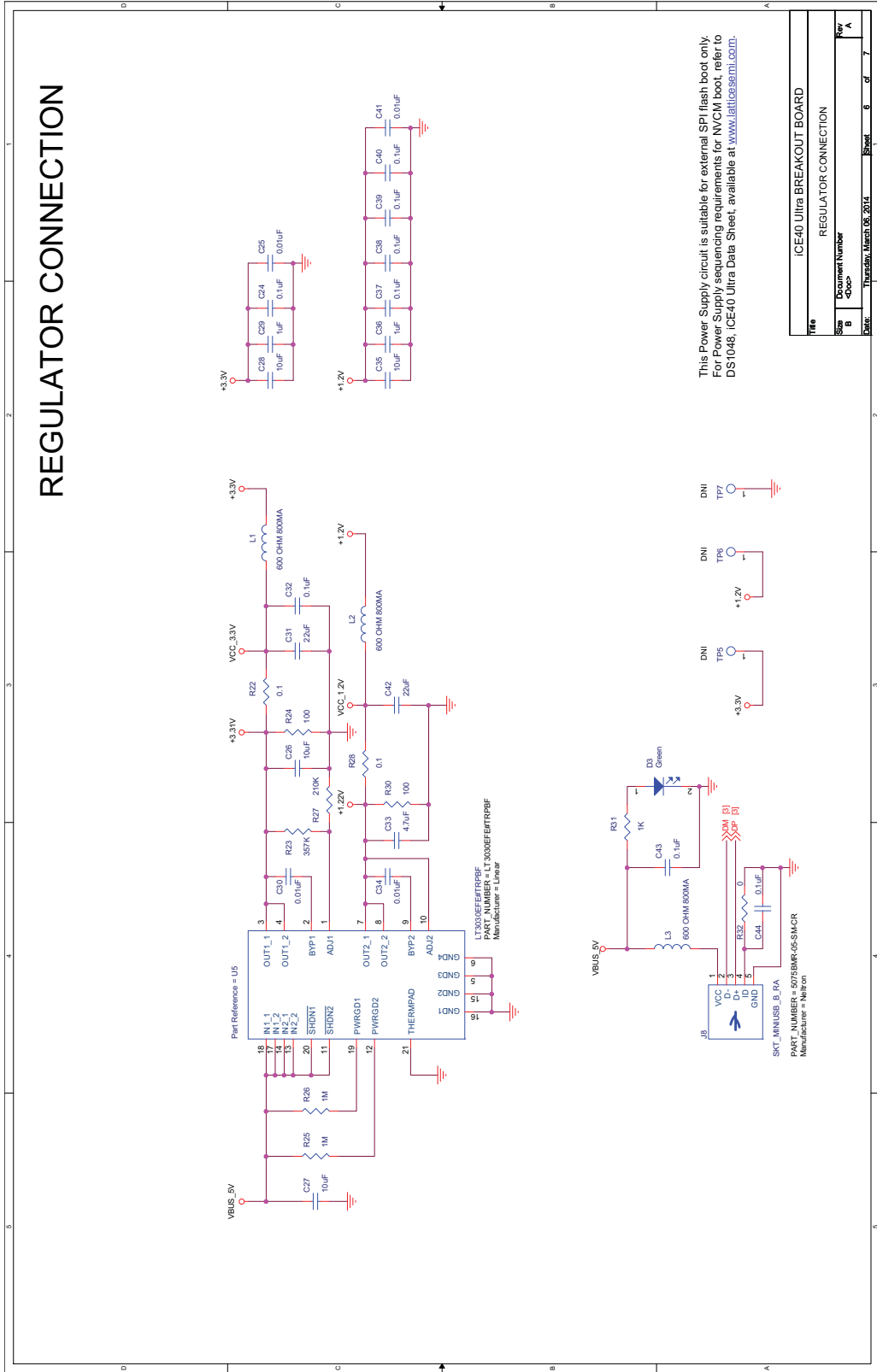
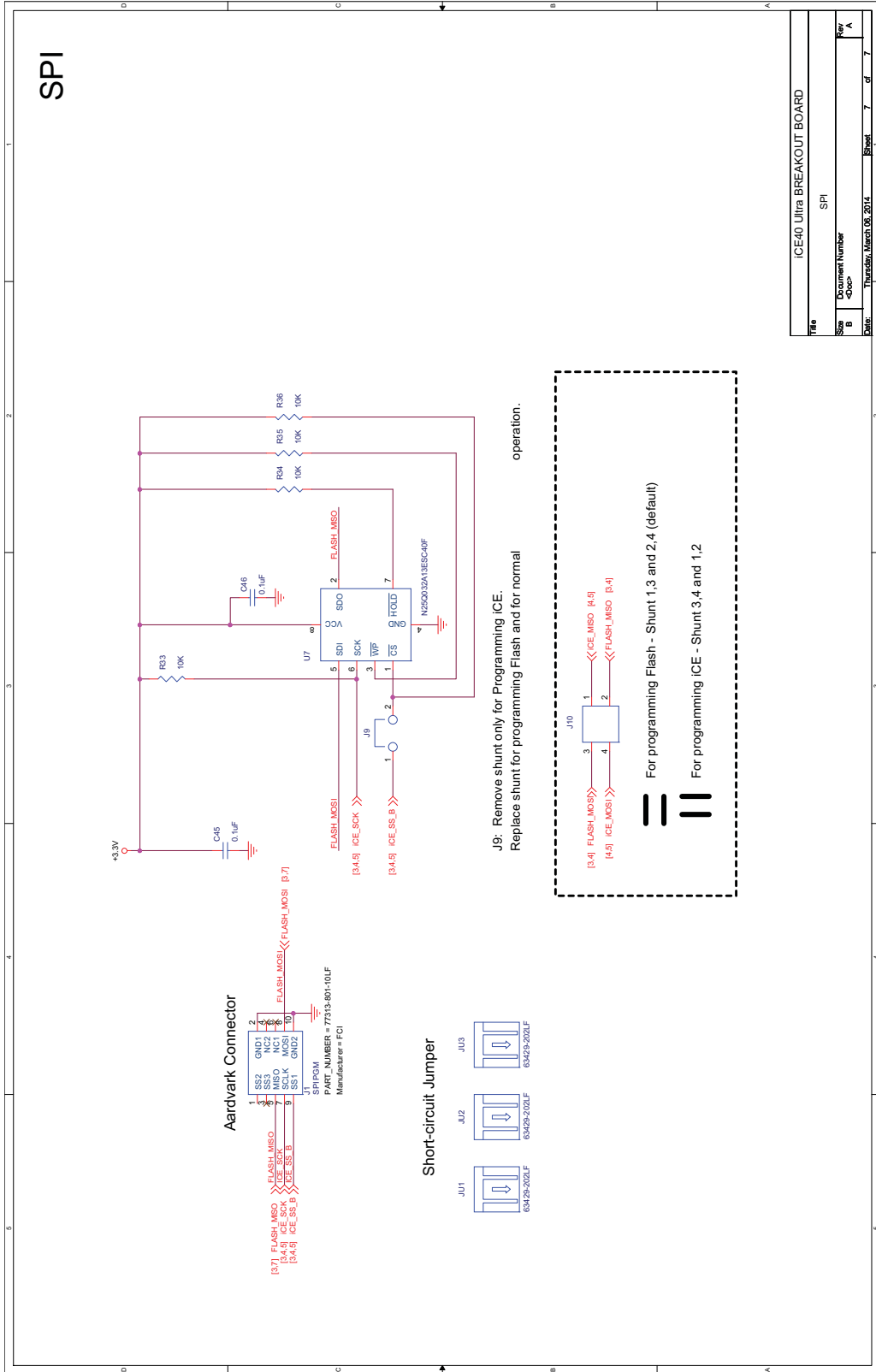

Figure 17. Regulator Connection



ICE40 Ultra BREAKOUT BOARD	
REGULATOR CONNECTION	
Rev	A
Doc	4-000
Sheet	6 of 7
Date:	Thursday, March 08, 2012

Figure 18. SPI



Appendix B. Bill of Materials

Item	Reference	Quantity	Part	PCB Footprint	PART_NUMBER	MFG	Description
1	C1,C3,C33	3	4.7uF	cc0603	ECJ-1VB0J475K	Panasonic	CAP CER 4.7UF 6.3 V 10% X5R 0603
2	C2, C4, C5, C6, C7, C8, C9, C11, C12, C13, C16, C17, C18, C21, C22, C24, C32, C37, C38, C39, C40, C43, C44, C45, C46, C65, C66, C67, C68, C72, C74	31	0.1uF	cc0603	C0603C104K4RACTU	Kemet	CAP CER 0.1UF 16 V 10% X7R 0603
3	C10, C19, C26, C27, C28, C35, C69	7	10uF	cc0603	LMK107BJ106MALTD	Taiyo Yuden	CAP CER 10UF 10 V 20% X5R 0603
4	C25,C30,C34,C41	4	0.01uF	cc0603	C0603C103J4RACTU	Kemet	CAP CER 10000PF 16 V 5% X7R 0603
5	C29,C36	2	1uF	cc0603	C0603C105K9PACTU	Kemet	CAP CER 1UF 6.3 V 10% X5R 0603
6	C31,C42	2	22uF	cc0805	LMK212BJ226MG-T	Taiyo Yuden	CAP CER 22UF 10 V 20% X5R 0805
7	D1	1	TSAL6200	2p54_TH_LED	TSAL6200	Vishay	EMITTER IR 5 MM HI EFF 940 NM
8	D2	1	Green	SM_D_0603	LG L29K-G2J1-24-Z	Osram	LED SMARTLED GREEN 570 NM 0603
9	D3	1	Green	led_0603	LTST-C190KGKT	LITE-On INC	LED SUPER GREEN CLEAR 0603 SMD
10	D6	1	CDBU0520	diode_sod523f	CDBU0520	Comchip	DIODE SCHOTTKY 20 V 500 MA 0603
11	D7	1	XBDAWT	2p54_TH_LED	XBDAWT-00-0000-00000LCE3	Cree	LED HIGH BRIGHTNESS
12	JU1,JU2,JU3	3	63429-202LF	-	63429-202LF	FCI	CONN SHUNT SINGLE .100 GOLD
13	J1	1	SPI PGM	hdr5x2	77313-801-10LF	FCI	CONN HEADER .100 DUAL STR 10POS
14	J2	1	CRST	HDR1X2-40	77311-801-02LF	FCI	CONN HEADER .100 SINGL STR 2POS
15	J3	1	DONE	HDR1X2-40	77311-801-02LF	FCI	CONN HEADER .100 SINGL STR 2POS
16	J4	1	HEADER 3X2	HDR3x2	-	-	-
17	J5	1	PMOD Connector	HDR_6x2_2MM	87758-1216	Molex	CONN HEADER 12POS 2 MM VERT GOLD
18	J6,J7	2	Header2x10	hdr_samtec_mtsw_2x10_100	MTSW-110-08-G-D-265	Samtec	CONN HEADER 20POS .100" TH GLD
19	J8	1	SKT_MINIUSB_B_RA	skt_miniusb_b_ra	5075BMR-05-SM-CR	Neltron	CONN MINI USB RCPT RA TYPE B SMD
20	J9	1	TSW-102-07-G-S	hdr_samtec_tsw_1x2_100	TSW-102-07-G-S	Samtec	CONN HEADER 2POS .100" SGL GOLD
21	J10	1	TSW-102-07-F-D	hdr_samtec_tsw_2x2_100	TSW-102-07-F-D	Samtec	CONN HEADER 4POS .100" DBL
22	J50	1	HDR 1X3 100MIL	HDR_1X3_100MIL	-	-	-
23	J51	1	2 PIN JPR	2PIN_100MIL	-	-	-
24	L1,L2,L3	3	600 OHM 800MA	fb0603	BLM18HE601SN1D	Murata	FERRITE CHIP 600 OHM 800 MA 0603
25	R1,R2,R3,R4,R5,R6,R32	7	0	cr0603	RC0603JR-070RL	Yageo	RES 0.0 OHM 1/10W JUMP 0603 SMD
26	R7,R12	2	2.2K	cr0603	ERJ-3EKF2201V	Panasonic	RES 2.2K OHM 1/10W 1% 0603 SMD
27	R8,R9,R10,R33,R34,R35,R36	7	10K	cr0603	RC0603FR-0710KL	Yageo	RES 10.0K OHM 1/10W 1% 0603 SMD
28	R11	1	12K	cr0603	RC0603FR-0712KL	Yageo	RES 12.0K OHM 1/10W 1% 0603 SMD
29	R14,R38	2	1	cr0603	CRCW06031R00FKEAH P	Vishay	RES 1.00 OHM .25W 1% 0603 SMD
30	R15,R96	2	1	cr0603	RC0603FR-07100RL	Yageo	RES 100 OHM 1/10W 1% 0603 SMD
31	R17	1	10k	R0603	ERJ-3EKF1002V	Panasonic	RES 10K OHM 1/10W 1% 0603 SMD
32	R18	1	2k2	R0603	ERJ-3EKF2201V	Panasonic	RES 2.2K OHM 1/10W 1% 0603 SMD
33	R22,R28	2	0.1	cr0603	ERJ-3RSFR10V	Panasonic	RES .10 OHM 1/10W 1% 0603 SMD
34	R23	1	357K	cr0603	ERJ-3EKF3573V	Panasonic	RES 357K OHM 1/10W 1% 0603 SMD
35	R24,R30	2	100	cr0603	RC0603FR-07100RL	Yageo	RES 100 OHM 1/10W 1% 0603 SMD
36	R25,R26	2	1M	cr0603	CRCW06031M00FKEA	Vishay	RES 1.00M OHM 1/10W 1% 0603 SMD
37	R27	1	210K	cr0603	ERJ-3EKF2103V	Panasonic	RES 210K OHM 1/10W 1% 0603 SMD
38	R31	1	1K	cr0603	RC0603FR-071KL	Yageo	RES 1.00K OHM 1/10W 1% 0603 SMD
39	R93,R98	2	2.2K	R0603	ERJ-3EKF2201V	Panasonic	RES 2.2K OHM 1/10W 1% 0603 SMD
40	R94,R97	2	100	SM_R_0603	ERJ-3GEYJ101V	Panasonic	RES 100 OHM 1/10W 5% 0603 SMD
41	R95	1	150	SM_R_0603	ERJ-3GEYJ151V	Panasonic	RES 150 OHM 1/10W 5% 0603 SMD
42	SW1	1	CRST	2psmd_eswitch	TL1015AF160QG	E-Switch	SWITCH TACTILE SPST-NO 0.05A 12 V
43	TP1, TP2, TP3, TP4, TP5, TP6, TP7, TP8, TP9, TP10, TP11	11	TP_S_40_63	tp_s_40_63	-	-	Square test point, 40mil inner diameter, 63mil outer diameter
44	U1	1	FT2232HL	tqfp64_0p5_12p2x12p2_h1p6	FT2232HL-REEL	FTDI	IC USB HS DUAL UART/FIFO 64-LQFP
45	U2	1	93LC56-SO8	so8_50_244	93LC56CT-I/SN	Microchip	IC EEPROM 2 KBIT 3 MHZ 8SOIC
46	U5	1	LT3030EFE#TRPBF	tssop20_26_260_t_hrm_pad	LT3030EFE#TRPBF	Linear	IC REG LDO ADJ 20TSSOP
47	U7	1	N25Q032A13ESC40F	so8_50_244	N25Q032A13ESC40F	Micron	IC Flash Mem Serial-SPI 3 V/3.3 V 32M-Bit 4M 7 ns 8-Pin SO T/R

Item	Reference	Quantity	Part	PCB Footprint	PART_NUMBER	MFG	Description
48	U8	1	ICE5LP4KSWG36	36_WLCSP	-	-	-
49	U9	1	LED TRI-COLOUR_1	6-PLCC	SFT722N-S	Seoul Semiconductor Inc	LED RED/GRN/BLU CLEAR LENS 6PLCC
50	X1	1	12.0000 MHZ	osc_4p_dsc3001	DSC3001HE2-012.0000T	Mirrel	OSCILLATOR 12.0000 MHZ -20°C to 70°C +/- 25 ppm 1.6 mm x 1.2 mm SMD
51	Thunder Breakout Board PCB	1	-	-	305-PD-14-0XXX	PACTRON	-