



**512K x 36, 1M x 18  
2.5V Synchronous ZBT™ SRAMs  
2.5V I/O, Burst Counter  
Pipelined Outputs**

AS8C163631  
AS8C161831

**Features**

- ◆ 512K x 36, 1M x 18 memory configurations
- ◆ Supports high performance system speed - 200 MHz (3.2 ns Clock-to-Data Access)
- ◆ ZBT™ Feature - No dead cycles between write and read cycles
- ◆ Internally synchronized output buffer enable eliminates the need to control OE
- ◆ Single R/W (READ/WRITE) control pin
- ◆ Positive clock-edge triggered address, data, and control signal registers for fully pipelined applications
- ◆ 4-word burst capability (interleaved or linear)
- ◆ Individual byte write (BW<sub>1</sub> - BW<sub>4</sub>) control (May tie active)
- ◆ Three chip enables for simple depth expansion
- ◆ 2.5V power supply (±5%)
- ◆ 2.5V I/O Supply (V<sub>DDQ</sub>)
- ◆ Power down controlled by ZZ input
- ◆ Boundary Scan JTAG Interface (IEEE 1149.1 Compliant)
- ◆ Packaged in a JEDEC standard 100-pin plastic thin quad flatpack (TQFP)

**Description**

The AS8C163631/1831 are 2.5V high-speed 18,874,368-bit (18 Megabit) synchronous SRAMs. They are designed to eliminate dead bus cycles when turning the bus around between reads and writes, or writes and reads. Thus, they have been given the name ZBT™, or Zero Bus Turnaround.

Address and control signals are applied to the SRAM during one clock cycle, and two cycles later the associated data cycle occurs, be it read or write.

The AS8C163631/1831 contain data I/O, address and control signal registers. Output enable is the only asynchronous signal and can be used to disable the outputs at any given time.

A Clock Enable CEN pin allows operation of the AS8C163631/1831 to be suspended as long as necessary. All synchronous inputs are ignored when CEN is high and the internal device registers will hold their previous values.

There are three chip enable pins (CE<sub>1</sub>, CE<sub>2</sub>, CE<sub>3</sub>) that allow the user to deselect the device when desired. If any one of these three is not asserted when ADV/LD is low, no new memory operation can be initiated.

**Pin Description Summary**

A <sub>0</sub> -A <sub>19</sub>	Address Inputs	Input	Synchronous
CE <sub>1</sub> , CE <sub>2</sub> , CE <sub>3</sub>	Chip Enables	Input	Synchronous
OE	Output Enable	Input	Asynchronous
R/W	Read/Write Signal	Input	Synchronous
CEN	Clock Enable	Input	Synchronous
BW <sub>1</sub> , BW <sub>2</sub> , BW <sub>3</sub> , BW <sub>4</sub>	Individual Byte Write Selects	Input	Synchronous
CLK	Clock	Input	N/A
ADV/LD	Advance burst address / Load new address	Input	Synchronous
LBO	Linear / Interleaved Burst Order	Input	Static
TMS	Test Mode Select	Input	N/A
TDI	Test Data Input	Input	N/A
TCK	Test Clock	Input	N/A
TDO	Test Data Output	Output	N/A
TRST	JTAG Reset (Optional)	Input	Asynchronous
ZZ	Sleep Mode	Input	Synchronous
I/O <sub>0</sub> -I/O <sub>31</sub> , I/O <sub>P1</sub> -I/O <sub>P4</sub>	Data Input / Output	I/O	Synchronous
V <sub>DD</sub> , V <sub>DDQ</sub>	Core Power, I/O Power	Supply	Static
V <sub>SS</sub>	Ground	Supply	Static

5313 b1 01

**OCTOBER 2010**

**Description (cont.)**

However, any pending data transfers (reads or writes) will be completed. The data bus will tri-state two cycles after the chip is deselected or a write is initiated.

The AS8C163631/1831 have an on-chip burst counter. In the burst mode, the AS8C163631/1831 can provide four cycles of data for a single address presented to the SRAM. The order of the burst sequence is defined by the  $\overline{\text{LBO}}$  input pin. The  $\overline{\text{LBO}}$  pin selects between linear and

interleaved burst sequence. The  $\overline{\text{ADV/LD}}$  signal is used to load a new external address ( $\overline{\text{ADV/LD}} = \text{LOW}$ ) or increment the internal burst counter ( $\overline{\text{ADV/LD}} = \text{HIGH}$ ).

The AS8C163631/1831 SRAMs utilize Alliance's latest high-performance 2.5V CMOS process, and are packaged in a JEDEC Standard 14mm x 20mm 100pin thin plastic quad flatpack (TQFP).

**Pin Definitions<sup>(1)</sup>**

Symbol	Pin Function	I/O	Active	Description
A0-A19	Address Inputs	I	N/A	Synchronous Address inputs. The address register is triggered by a combination of the rising edge of CLK, $\overline{\text{ADV/LD}}$ low, $\overline{\text{CEN}}$ low, and true chip enables.
$\overline{\text{ADV/LD}}$	Advance / Load	I	N/A	$\overline{\text{ADV/LD}}$ is a synchronous input that is used to load the internal registers with new address and control when it is sampled low at the rising edge of clock with the chip selected. When $\overline{\text{ADV/LD}}$ is low with the chip deselected, any burst in progress is terminated. When $\overline{\text{ADV/LD}}$ is sampled high then the internal burst counter is advanced for any burst that was in progress. The external addresses are ignored when $\overline{\text{ADV/LD}}$ is sampled high.
$\overline{\text{R/W}}$	Read / Write	I	N/A	$\overline{\text{R/W}}$ signal is a synchronous input that identifies whether the current load cycle initiated is a Read or Write access to the memory array. The data bus activity for the current cycle takes place two clock cycles later.
$\overline{\text{CEN}}$	Clock Enable	I	LOW	Synchronous Clock Enable Input. When $\overline{\text{CEN}}$ is sampled high, all other synchronous inputs, including clock are ignored and outputs remain unchanged. The effect of $\overline{\text{CEN}}$ sampled high on the device outputs is as if the low to high clock transition did not occur. For normal operation, $\overline{\text{CEN}}$ must be sampled low at rising edge of clock.
$\overline{\text{BW}}_1$ - $\overline{\text{BW}}_4$	Individual Byte Write Enables	I	LOW	Synchronous byte write enables. Each 9-bit byte has its own active low byte write enable. On load write cycles (when $\overline{\text{R/W}}$ and $\overline{\text{ADV/LD}}$ are sampled low) the appropriate byte write signal ( $\overline{\text{BW}}_1$ - $\overline{\text{BW}}_4$ ) must be valid. The byte write signal must also be valid on each cycle of a burst write. Byte Write signals are ignored when $\overline{\text{R/W}}$ is sampled high. The appropriate byte(s) of data are written into the device two cycles later. $\overline{\text{BW}}_1$ - $\overline{\text{BW}}_4$ can all be tied low if always doing write to the entire 36-bit word.
$\overline{\text{CE}}_1$ , $\overline{\text{CE}}_2$	Chip Enables	I	LOW	Synchronous active low chip enable. $\overline{\text{CE}}_1$ and $\overline{\text{CE}}_2$ are used with $\overline{\text{CE}}_2$ to enable the AS8C163631/1831 ( $\overline{\text{CE}}_1$ or $\overline{\text{CE}}_2$ sampled high or $\overline{\text{CE}}_2$ sampled low) and $\overline{\text{ADV/LD}}$ low at the rising edge of clock, initiates a deselect cycle. The ZBT™ has a two cycle deselect, i.e., the data bus will tri-state two clock cycles after deselect is initiated.
$\text{CE}_2$	Chip Enable	I	HIGH	Synchronous active high chip enable. $\text{CE}_2$ is used with $\overline{\text{CE}}_1$ and $\overline{\text{CE}}_2$ to enable the chip. $\text{CE}_2$ has inverted polarity but otherwise identical to $\overline{\text{CE}}_1$ and $\overline{\text{CE}}_2$ .
CLK	Clock	I	N/A	This is the clock input to the AS8C163631/1831. Except for $\overline{\text{OE}}$ , all timing references for the device are made with respect to the rising edge of CLK.
$\text{I/O}_0$ - $\text{I/O}_{31}$ $\text{I/O}_{P1}$ - $\text{I/O}_{P4}$	Data Input/Output	I/O	N/A	Synchronous data input/output (I/O) pins. Both the data input path and data output path are registered and triggered by the rising edge of CLK.
$\overline{\text{LBO}}$	Linear Burst Order	I	LOW	Burst order selection input. When $\overline{\text{LBO}}$ is high the interleaved burst sequence is selected. When $\overline{\text{LBO}}$ is low the Linear burst sequence is selected. $\overline{\text{LBO}}$ is a static input and it must not change during device operation.
$\overline{\text{OE}}$	Output Enable	I	LOW	Asynchronous output enable. $\overline{\text{OE}}$ must be low to read data from the AS8C163631/1831. When $\overline{\text{OE}}$ is high the I/O pins are in a high-impedance state. $\overline{\text{OE}}$ does not need to be actively controlled for read and write cycles. In normal operation, $\overline{\text{OE}}$ can be tied low.
TMS	Test Mode Select	I	N/A	Gives input command for TAP controller. Sampled on rising edge of TCK. This pin has an internal pullup.
TDI	Test Data Input	I	N/A	Serial input of registers placed between TDI and TDO. Sampled on rising edge of TCK. This pin has an internal pullup.
TCK	Test Clock	I	N/A	Clock input of TAP controller. Each TAP event is clocked. Test inputs are captured on rising edge of TCK while test outputs are driven from the falling edge of TCK. This pin has an internal pullup.
TDO	Test Data Output	O	N/A	Serial output of registers placed between TDI and TDO. This output is active depending on the state of the TAP controller.
$\overline{\text{TRST}}$	JTAG Reset (Optional)	I	LOW	Optional asynchronous JTAG reset. Can be used to reset the TAP controller but not required. JTAG reset occurs automatically at power up and also resets using TMS and TCK per IEEE 1149.1. If not used $\overline{\text{TRST}}$ can be left floating. This pin has an internal pullup. Only available in BGA package.
ZZ	Sleep Mode	I	HIGH	Synchronous sleep mode input. ZZ HIGH will gate the CLK internally and power down the AS8C163631/1831 to its lowest power consumption level. Data retention is guaranteed in Sleep Mode. This pin has an internal pulldown.
VDD	Power Supply	N/A	N/A	2.5V core power supply.
VDDQ	Power Supply	N/A	N/A	2.5V I/O Supply.
VSS	Ground	N/A	N/A	Ground.

**NOTE:**

- 1 All synchronous inputs must meet specified setup and hold times with respect to CLK.

### Functional Block Diagram

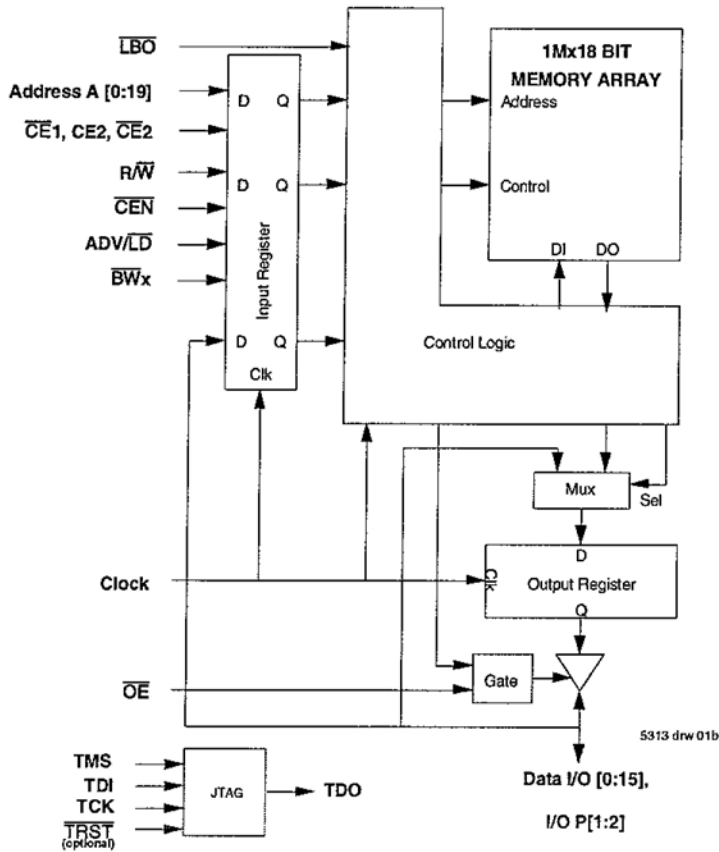
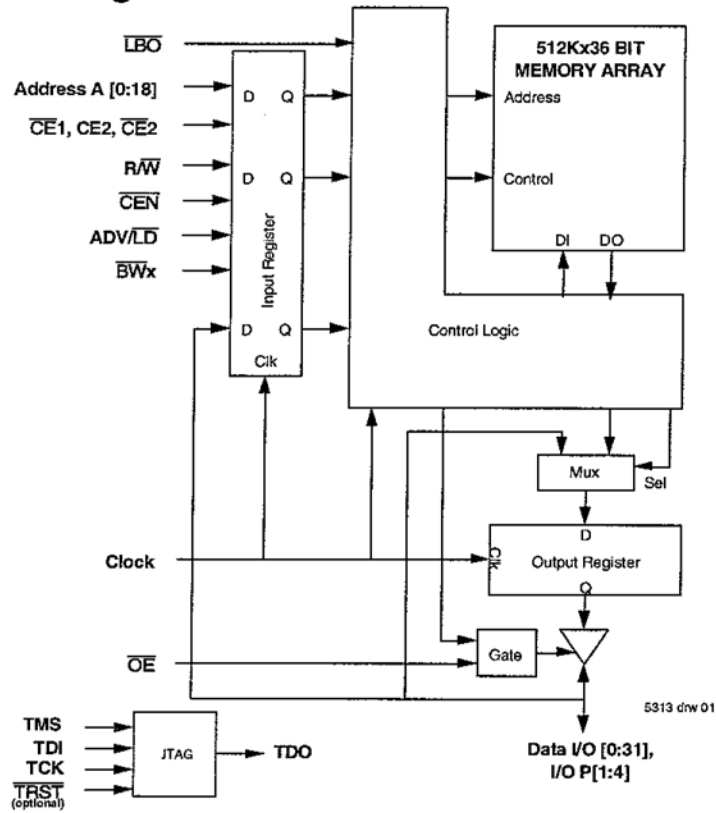

### Recommended DC Operating Conditions

Symbol	Parameter	Min	Typ	Max	Unit
V <sub>DD</sub>	Core Supply Voltage	2.375	2.5	2.625	V
V <sub>DDQ</sub>	I/O Supply Voltage	2.375	2.5	2.625	V
V <sub>SS</sub>	Ground	0	0	0	V
V <sub>H</sub>	Input High Voltage - Inputs	1.7	—	V <sub>DD</sub> + 0.3	V
V <sub>H</sub>	Input High Voltage - I/O	1.7	—	V <sub>DDQ</sub> + 0.3	V
V <sub>IL</sub>	Input Low Voltage	-0.3 <sup>(1)</sup>	—	0.7	V

5313 tbl 03

**NOTE:**

1 V<sub>IL</sub> (min) = -0.8V for pulse width less than t<sub>cy</sub>/2, once per cycle

### Recommended Operating Temperature and Supply Voltage

Grade	Ambient Temperature <sup>(1)</sup>	V <sub>SS</sub>	V <sub>DD</sub>	V <sub>DDQ</sub>
Commercial	0° C to +70° C	OV	2.5V ± 5%	2.5V ± 5%
Industrial	-40° C to +85° C	OV	2.5V ± 5%	2.5V ± 5%

5313 tbl 05

**NOTE:**

1 During production testing the case temperature equals the ambient temperature

### Pin Configuration — 512K x 36

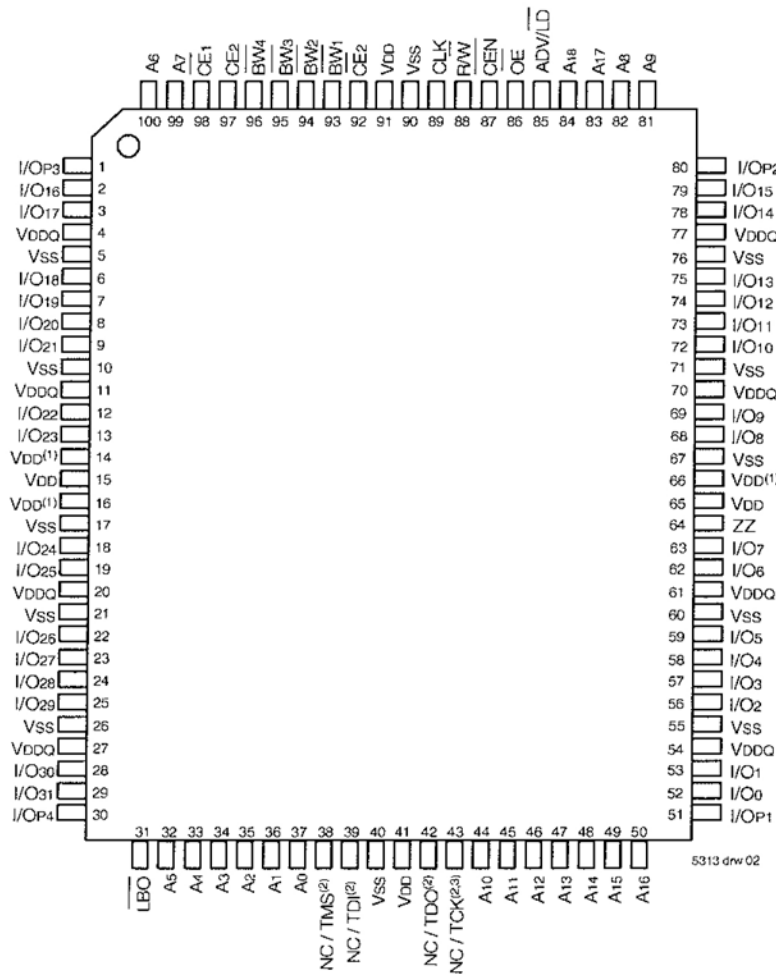

5313 dnr 02

### Top View 100 TQFP

**NOTES:**

- 1 Pins 14, 16, and 66 do not have to be connected directly to V<sub>DD</sub> as long as the input voltage is ≥ V<sub>H</sub>
- 2 Pins 38, 39, and 43 will be pulled internally to V<sub>DD</sub> if not actively driven. To disable the TAP controller without interfering with normal operation, several settings are possible. Pins 38, 39, and 43 could be tied to V<sub>DD</sub> or V<sub>SS</sub> and pin 42 should be left unconnected. Or all JTAG inputs (TMS, TDI, and TCK) pins 38, 39, and 43 could be left unconnected. "NC" and the JTAG circuit will remain disabled from power up.
- 3 Pin 43 is reserved for the 36M address. JTAG is not offered in the 100-pin TQFP package for the 36M ZBT device.

### Pin Configuration — 1Mx 18

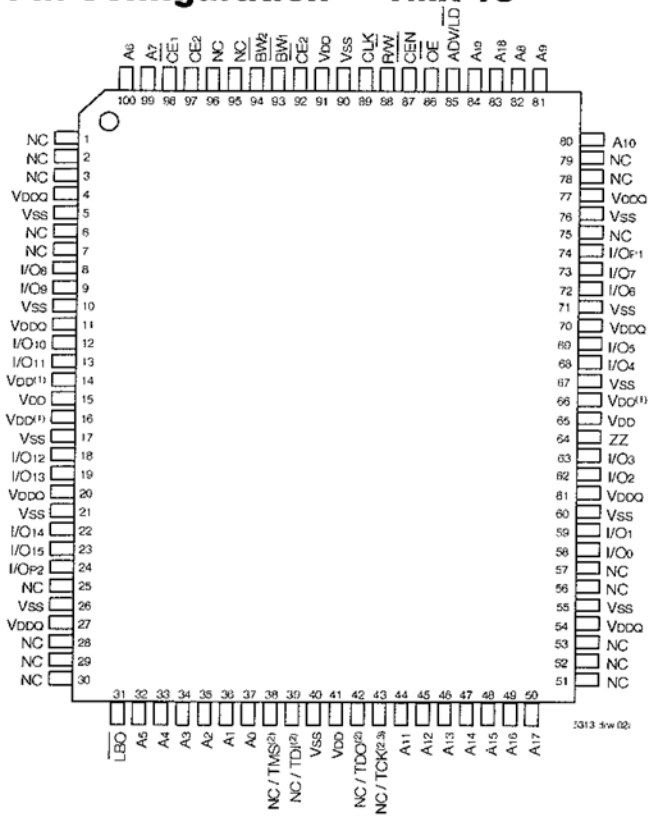

### Top View 100 TQFP

**NOTES:**

- 1 Pins 14, 16, and 66 do not have to be connected directly to VDD as long as the input voltage is  $\geq V_{IH}$
- 2 Pins 38, 39 and 43 will be pulled internally to VDD if not actively driven. To disable the TAP controller without interfering with normal operation, several settings are possible. Pins 38, 39 and 43 could be tied to VDD or VSS and pin 42 should be left unconnected. Or all JTAG inputs (TMS, TDI and TCK) pins 38, 39 and 43 could be left unconnected "NC" and the JTAG circuit will remain disabled from power up.
- 3 Pin 43 is reserved for the 36M address. JTAG is not offered in the 100-pin TQFP package for the 36M ZBT device.

### 100-Pin TQFP Capacitance

(TA = +25°C, f = 1.0MHz)

Symbol	Parameter <sup>(1)</sup>	Conditions	Max.	Unit
C <sub>IN</sub>	Input Capacitance	V <sub>IN</sub> = 3dV	5	pF
C <sub>VO</sub>	I/O Capacitance	V <sub>OUT</sub> = 3dV	7	pF

5313 10/07

### Absolute Maximum Ratings<sup>(1)</sup>

Symbol	Rating	Commercial	Industrial	Unit
V <sub>TERM</sub> <sup>(2)</sup>	Terminal Voltage with Respect to GND	-0.5 to +3.6	-0.5 to +3.6	V
V <sub>TERM</sub> <sup>(3,6)</sup>	Terminal Voltage with Respect to GND	-0.5 to V <sub>DD</sub>	-0.5 to V <sub>DD</sub>	V
V <sub>TERM</sub> <sup>(4,6)</sup>	Terminal Voltage with Respect to GND	-0.5 to V <sub>DD</sub> +0.5	-0.5 to V <sub>DD</sub> +0.5	V
V <sub>TERM</sub> <sup>(5,6)</sup>	Terminal Voltage with Respect to GND	-0.5 to V <sub>DDQ</sub> +0.5	-0.5 to V <sub>DDQ</sub> +0.5	V
T <sub>A</sub> <sup>(7)</sup>	Operating Ambient Temperature	0 to +70	-40 to +85	°C
T <sub>BIAS</sub>	Temperature Under Bias	-55 to +125	-55 to +125	°C
T <sub>STG</sub>	Storage Temperature	-55 to +125	-55 to +125	°C
P <sub>T</sub>	Power Dissipation	2.0	2.0	W
I <sub>OUT</sub>	DC Output Current	50	50	mA

5313 10/07

**NOTES:**

- 1 Stresses greater than those listed under ABSOLUTE MAXIMUM RATINGS may cause permanent damage to the device. This is a stress rating only and functional operation of the device at these or any other conditions above those indicated in the operational sections of this specification is not implied. Exposure to absolute maximum rating conditions for extended periods may affect reliability.
- 2 V<sub>DD</sub> terminals only.
- 3 V<sub>DDQ</sub> terminals only.
- 4 Input terminals only.
- 5 I/O terminals only.
- 6 This is a steady-state DC parameter that applies after the power supply has reached its nominal operating value. Power sequencing is not necessary; however, the voltage on any input or I/O pin cannot exceed V<sub>DDQ</sub> during power supply ramp up.
- 7 During production testing, the case temperature equals T<sub>A</sub>.

### Synchronous Truth Table<sup>(1)</sup>

$\overline{CEN}$	R/W	Chip <sup>(5)</sup> Enable	$\overline{ADV}/\overline{LD}$	$\overline{BW}_x$	ADDRESS USED	PREVIOUS CYCLE	CURRENT CYCLE	I/O (2 cycles later)
L	L	Select	L	Valid	External	X	LOAD WRITE	D <sup>(7)</sup>
L	H	Select	L	X	External	X	LOAD READ	Q <sup>(7)</sup>
L	X	X	H	Valid	Internal	LOAD WRITE / BURST WRITE	BURST WRITE (Advance burst counter) <sup>(2)</sup>	D <sup>(7)</sup>
L	X	X	H	X	Internal	LOAD READ / BURST READ	BURST READ (Advance burst counter) <sup>(2)</sup>	Q <sup>(7)</sup>
L	X	Deselect	L	X	X	X	DESELECT or STOP <sup>(6)</sup>	HiZ
L	X	X	H	X	X	DESELECT / NOOP	NOOP	HiZ
H	X	X	X	X	X	X	SUSPEND <sup>(4)</sup>	Previous Value

5313 tbl 05

**NOTES:**

- 1 L = V<sub>IL</sub>, H = V<sub>IH</sub>, X = Don't Care
- 2 When  $\overline{ADV}/\overline{LD}$  signal is sampled high, the internal burst counter is incremented. The R/W signal is ignored when the counter is advanced. Therefore the nature of the burst cycle (Read or Write) is determined by the status of the R/W signal when the first address is loaded at the beginning of the burst cycle.
- 3 Deselect cycle is initiated when either  $\overline{CE}_1$  or  $\overline{CE}_2$  is sampled high or CE<sub>2</sub> is sampled low) and  $\overline{ADV}/\overline{LD}$  is sampled low at rising edge of clock. The data bus will tri-state two cycles after deselect is initiated.
- 4 When  $\overline{CEN}$  is sampled high at the rising edge of clock, that clock edge is blocked from propagating through the part. The state of all the internal registers and the I/Os remains unchanged.
- 5 To select the chip requires  $\overline{CE}_1 = L, \overline{CE}_2 = L, CE_2 = H$  on these chip enables. Chip is deselected if any one of the chip enables is false.
- 6 Device Outputs are ensured to be in High-Z after the first rising edge of clock upon power-up.
- 7 Q - Data read from the device. D - data written to the device.

### Partial Truth Table for Writes<sup>(1)</sup>

OPERATION	R/W	$\overline{BW}_1$	$\overline{BW}_2$	$\overline{BW}_3$ <sup>(3)</sup>	$\overline{BW}_4$ <sup>(3)</sup>
READ	H	X	X	X	X
WRITE ALL BYTES	L	L	L	L	L
WRITE BYTE 1 (I/O[0:7], I/OP1) <sup>(2)</sup>	L	L	H	H	H
WRITE BYTE 2 (I/O[8:15], I/OP2) <sup>(2)</sup>	L	H	L	H	H
WRITE BYTE 3 (I/O[16:23], I/OP3) <sup>(2,3)</sup>	L	H	H	L	H
WRITE BYTE 4 (I/O[24:31], I/OP4) <sup>(2,3)</sup>	L	H	H	H	L
NO WRITE	L	H	H	H	H

5313 tbl 09

**NOTES:**

- 1 L = V<sub>IL</sub>, H = V<sub>IH</sub>, X = Don't Care
- 2 Multiple bytes may be selected during the same cycle.
- 3 N/A for X18 configuration.

### Interleaved Burst Sequence Table ( $\overline{\text{LBO}}=\text{VDD}$ )

	Sequence 1		Sequence 2		Sequence 3		Sequence 4	
	A1	A0	A1	A0	A1	A0	A1	A0
First Address	0	0	0	1	1	0	1	1
Second Address	0	1	0	0	1	1	1	0
Third Address	1	0	1	1	0	0	0	1
Fourth Address <sup>(1)</sup>	1	1	1	0	0	1	0	0

5313 tbl 10

**NOTE:**

1 Upon completion of the Burst sequence the counter wraps around to its initial state and continues counting

### Linear Burst Sequence Table ( $\overline{\text{LBO}}=\text{Vss}$ )

	Sequence 1		Sequence 2		Sequence 3		Sequence 4	
	A1	A0	A1	A0	A1	A0	A1	A0
First Address	0	0	0	1	1	0	1	1
Second Address	0	1	1	0	1	1	0	0
Third Address	1	0	1	1	0	0	0	1
Fourth Address <sup>(1)</sup>	1	1	0	0	0	1	1	0

5313 tbl 11

**NOTE:**

1 Upon completion of the Burst sequence the counter wraps around to its initial state and continues counting

### Functional Timing Diagram<sup>(1)</sup>

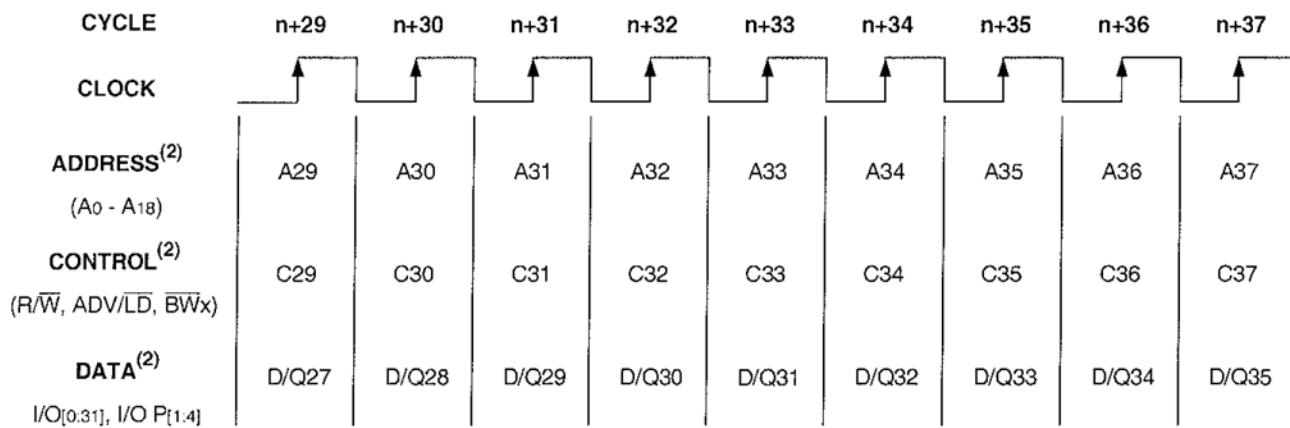

5313drw 03

**NOTES:**

1 This assumes  $\overline{\text{CEN}}$ ,  $\overline{\text{CE1}}$ ,  $\text{CE2}$ ,  $\overline{\text{CE2}}$  are all true

2 All Address, Control and Data\_In are only required to meet set-up and hold time with respect to the rising edge of clock. Data\_Out is valid after a clock-to-data delay from the rising edge of clock

## Device Operation - Showing Mixed Load, Burst, Deselect and NOOP Cycles<sup>(2)</sup>

Cycle	Address	R/ $\bar{W}$	ADV/ $\bar{LD}$	$\bar{CE}^{(1)}$	$\bar{CEN}$	$\bar{BW}_x$	$\bar{OE}$	I/O	Comments
n	A <sub>0</sub>	H	L	L	L	X	X	X	Load read
n+1	X	X	H	X	L	X	X	X	Burst read
n+2	A <sub>1</sub>	H	L	L	L	X	L	Q <sub>0</sub>	Load read
n+3	X	X	L	H	L	X	L	Q <sub>0+1</sub>	Deselect or STOP
n+4	X	X	H	X	L	X	L	Q <sub>1</sub>	NOOP
n+5	A <sub>2</sub>	H	L	L	L	X	X	Z	Load read
n+6	X	X	H	X	L	X	X	Z	Burst read
n+7	X	X	L	H	L	X	L	Q <sub>2</sub>	Deselect or STOP
n+8	A <sub>3</sub>	L	L	L	L	L	L	Q <sub>2+1</sub>	Load write
n+9	X	X	H	X	L	L	X	Z	Burst write
n+10	A <sub>4</sub>	L	L	L	L	L	X	D <sub>3</sub>	Load write
n+11	X	X	L	H	L	X	X	D <sub>3+1</sub>	Deselect or STOP
n+12	X	X	H	X	L	X	X	D <sub>4</sub>	NOOP
n+13	A <sub>5</sub>	L	L	L	L	L	X	Z	Load write
n+14	A <sub>6</sub>	H	L	L	L	X	X	Z	Load read
n+15	A <sub>7</sub>	L	L	L	L	L	X	D <sub>5</sub>	Load write
n+16	X	X	H	X	L	L	L	Q <sub>6</sub>	Burst write
n+17	A <sub>8</sub>	H	L	L	L	X	X	D <sub>7</sub>	Load read
n+18	X	X	H	X	L	X	X	D <sub>7+1</sub>	Burst read
n+19	A <sub>9</sub>	L	L	L	L	L	L	Q <sub>8</sub>	Load write

5313 tbl 12

## NOTES:

- $\bar{CE} = L$  is defined as  $\bar{CE}_1 = L$ ,  $\bar{CE}_2 = L$  and  $CE_2 = H$ .  $\bar{CE} = H$  is defined as  $\bar{CE}_1 = H$ ,  $\bar{CE}_2 = H$  or  $CE_2 = L$ .
- H = High; L = Low; X = Don't Care; Z = High Impedance

## Read Operation<sup>(1)</sup>

Cycle	Address	R/ $\bar{W}$	ADV/ $\bar{LD}$	$\bar{CE}^{(2)}$	$\bar{CEN}$	$\bar{BW}_x$	$\bar{OE}$	I/O	Comments
n	A <sub>0</sub>	H	L	L	L	X	X	X	Address and Control meet setup
n+1	X	X	X	X	L	X	X	X	Clock Setup Valid
n+2	X	X	X	X	X	X	L	Q <sub>0</sub>	Contents of Address A <sub>0</sub> Read Out

5313 tbl 13

## NOTES:

- H = High; L = Low; X = Don't Care; Z = High Impedance
- $\bar{CE} = L$  is defined as  $CE_1 = L$ ,  $\bar{CE}_2 = L$  and  $CE_2 = H$ .  $\bar{CE} = H$  is defined as  $\bar{CE}_1 = H$ ,  $\bar{CE}_2 = H$  or  $CE_2 = L$ .



### Burst Read Operation<sup>(1)</sup>

Cycle	Address	R/ $\bar{W}$	ADV/ $\bar{LD}$	$\bar{CE}^{(2)}$	$\bar{CEN}$	$\bar{BW}_x$	$\bar{OE}$	I/O	Comments
n	A <sub>0</sub>	H	L	L	L	X	X	X	Address and Control meet setup
n+1	X	X	H	X	L	X	X	X	Clock Setup Valid, Advance Counter
n+2	X	X	H	X	L	X	L	Q <sub>0</sub>	Address A <sub>0</sub> Read Out, Inc. Count
n+3	X	X	H	X	L	X	L	Q <sub>0+1</sub>	Address A <sub>0+1</sub> Read Out, Inc. Count
n+4	X	X	H	X	L	X	L	Q <sub>0+2</sub>	Address A <sub>0+2</sub> Read Out, Inc. Count
n+5	A <sub>1</sub>	H	L	L	L	X	L	Q <sub>0+3</sub>	Address A <sub>0+3</sub> Read Out, Load A <sub>1</sub>
n+6	X	X	H	X	L	X	L	Q <sub>0</sub>	Address A <sub>0</sub> Read Out, Inc. Count
n+7	X	X	H	X	L	X	L	Q <sub>1</sub>	Address A <sub>1</sub> Read Out, Inc. Count
n+8	A <sub>2</sub>	H	L	L	L	X	L	Q <sub>1+1</sub>	Address A <sub>1+1</sub> Read Out, Load A <sub>2</sub>

5313 tbl 14

**NOTES:**

1 H = High; L = Low; X = Don't Care; Z = High Impedance

2  $\bar{CE} = L$  is defined as  $\bar{CE}_1 = L$ ,  $\bar{CE}_2 = L$  and  $CE_2 = H$ .  $\bar{CE} = H$  is defined as  $\bar{CE}_1 = H$ ,  $\bar{CE}_2 = H$  or  $CE_2 = L$ .

### Write Operation<sup>(1)</sup>

Cycle	Address	R/ $\bar{W}$	ADV/ $\bar{LD}$	$\bar{CE}^{(2)}$	$\bar{CEN}$	$\bar{BW}_x$	$\bar{OE}$	I/O	Comments
n	A <sub>0</sub>	L	L	L	L	L	X	X	Address and Control meet setup
n+1	X	X	X	X	L	X	X	X	Clock Setup Valid
n+2	X	X	X	X	L	X	X	D <sub>0</sub>	Write to Address A <sub>0</sub>

5313 tbl 15

**NOTES:**

1 H = High; L = Low; X = Don't Care; Z = High Impedance

2  $\bar{CE} = L$  is defined as  $\bar{CE}_1 = L$ ,  $\bar{CE}_2 = L$  and  $CE_2 = H$ .  $\bar{CE} = H$  is defined as  $\bar{CE}_1 = H$ ,  $\bar{CE}_2 = H$  or  $CE_2 = L$ .

### Burst Write Operation<sup>(1)</sup>

Cycle	Address	R/ $\bar{W}$	ADV/ $\bar{LD}$	$\bar{CE}^{(2)}$	$\bar{CEN}$	$\bar{BW}_x$	$\bar{OE}$	I/O	Comments
n	A <sub>0</sub>	L	L	L	L	L	X	X	Address and Control meet setup
n+1	X	X	H	X	L	L	X	X	Clock Setup Valid, Inc. Count
n+2	X	X	H	X	L	L	X	D <sub>0</sub>	Address A <sub>0</sub> Write, Inc. Count
n+3	X	X	H	X	L	L	X	D <sub>0+1</sub>	Address A <sub>0+1</sub> Write, Inc. Count
n+4	X	X	H	X	L	L	X	D <sub>0+2</sub>	Address A <sub>0+2</sub> Write, Inc. Count
n+5	A <sub>1</sub>	L	L	L	L	L	X	D <sub>0+3</sub>	Address A <sub>0+3</sub> Write, Load A <sub>1</sub>
n+6	X	X	H	X	L	L	X	D <sub>0</sub>	Address A <sub>0</sub> Write, Inc. Count
n+7	X	X	H	X	L	L	X	D <sub>1</sub>	Address A <sub>1</sub> Write, Inc. Count
n+8	A <sub>2</sub>	L	L	L	L	L	X	D <sub>1+1</sub>	Address A <sub>1+1</sub> Write, Load A <sub>2</sub>

5313 tbl 16

**NOTES:**

1 H = High; L = Low; X = Don't Care; ? = Don't Know; Z = High Impedance

2  $\bar{CE} = L$  is defined as  $\bar{CE}_1 = L$ ,  $\bar{CE}_2 = L$  and  $CE_2 = H$ .  $\bar{CE} = H$  is defined as  $\bar{CE}_1 = H$ ,  $\bar{CE}_2 = H$  or  $CE_2 = L$ .

**Read Operation with Clock Enable Used<sup>(1)</sup>**

Cycle	Address	R/ $\overline{W}$	ADV/ $\overline{LD}$	$\overline{CE}^{(2)}$	$\overline{CEN}$	$\overline{BW}_x$	$\overline{OE}$	I/O	Comments
n	A <sub>0</sub>	H	L	L	L	X	X	X	Address and Control meet setup
n+1	X	X	X	X	H	X	X	X	Clock n+1 Ignored
n+2	A <sub>1</sub>	H	L	L	L	X	X	X	Clock Valid
n+3	X	X	X	X	H	X	L	Q <sub>0</sub>	Clock Ignored. Data Q <sub>0</sub> is on the bus.
n+4	X	X	X	X	H	X	L	Q <sub>0</sub>	Clock Ignored. Data Q <sub>0</sub> is on the bus.
n+5	A <sub>2</sub>	H	L	L	L	X	L	Q <sub>0</sub>	Address A <sub>0</sub> Read out (bus trans.)
n+6	A <sub>3</sub>	H	L	L	L	X	L	Q <sub>1</sub>	Address A <sub>1</sub> Read out (bus trans.)
n+7	A <sub>4</sub>	H	L	L	L	X	L	Q <sub>2</sub>	Address A <sub>2</sub> Read out (bus trans.)

5313 tbl 17

**NOTES:**

- H = High; L = Low; X = Don't Care; Z = High Impedance.
- $\overline{CE} = L$  is defined as  $\overline{CE}_1 = L$ ,  $\overline{CE}_2 = L$  and  $CE_2 = H$ .  $\overline{CE} = H$  is defined as  $\overline{CE}_1 = H$ ,  $\overline{CE}_2 = H$  or  $CE_2 = L$ .

**Write Operation with Clock Enable Used<sup>(1)</sup>**

Cycle	Address	R/ $\overline{W}$	ADV/ $\overline{LD}$	$\overline{CE}^{(2)}$	$\overline{CEN}$	$\overline{BW}_x$	$\overline{OE}$	I/O	Comments
n	A <sub>0</sub>	L	L	L	L	L	X	X	Address and Control meet setup.
n+1	X	X	X	X	H	X	X	X	Clock n+1 Ignored.
n+2	A <sub>1</sub>	L	L	L	L	L	X	X	Clock Valid.
n+3	X	X	X	X	H	X	X	X	Clock Ignored.
n+4	X	X	X	X	H	X	X	X	Clock Ignored.
n+5	A <sub>2</sub>	L	L	L	L	L	X	D <sub>0</sub>	Write Data D <sub>0</sub>
n+6	A <sub>3</sub>	L	L	L	L	L	X	D <sub>1</sub>	Write Data D <sub>1</sub>
n+7	A <sub>4</sub>	L	L	L	L	L	X	D <sub>2</sub>	Write Data D <sub>2</sub>

5313 tbl 18

**NOTES:**

- H = High; L = Low; X = Don't Care; Z = High Impedance.
- $\overline{CE} = L$  is defined as  $\overline{CE}_1 = L$ ,  $\overline{CE}_2 = L$  and  $CE_2 = H$ .  $\overline{CE} = H$  is defined as  $\overline{CE}_1 = H$ ,  $\overline{CE}_2 = H$  or  $CE_2 = L$ .

### Read Operation with Chip Enable Used<sup>(1)</sup>

Cycle	Address	R/W	ADV/LD	$\overline{CE}^{(2)}$	$\overline{CEN}$	$\overline{BWx}$	$\overline{OE}$	I/O <sup>(3)</sup>	Comments
n	X	X	L	H	L	X	X	?	Deselected
n+1	X	X	L	H	L	X	X	?	Deselected
n+2	A <sub>0</sub>	H	L	L	L	X	X	Z	Address and Control meet setup.
n+3	X	X	L	H	L	X	X	Z	Deselected or STOP.
n+4	A <sub>1</sub>	H	L	L	L	X	L	Q <sub>0</sub>	Address A <sub>0</sub> Read out. Load A <sub>1</sub> .
n+5	X	X	L	H	L	X	X	Z	Deselected or STOP.
n+6	X	X	L	H	L	X	L	Q <sub>1</sub>	Address A <sub>1</sub> Read out. Deselected.
n+7	A <sub>2</sub>	H	L	L	L	X	X	Z	Address and control meet setup.
n+8	X	X	L	H	L	X	X	Z	Deselected or STOP.
n+9	X	X	L	H	L	X	L	Q <sub>2</sub>	Address A <sub>2</sub> Read out. Deselected.

5313 tbl 19

**NOTES:**

- 1 H = High; L = Low; X = Don't Care; ? = Don't Know; Z = High Impedance
- 2  $\overline{CE} = L$  is defined as  $\overline{CE}_1 = L$   $\overline{CE}_2 = L$  and  $CE_2 = H$   $\overline{CE} = H$  is defined as  $\overline{CE}_1 = H$   $\overline{CE}_2 = H$  or  $CE_2 = L$
- 3 Device Outputs are ensured to be in High-Z after the first rising edge of clock upon power-up

### Write Operation with Chip Enable Used<sup>(1)</sup>

Cycle	Address	R/W	ADV/LD	$\overline{CE}^{(2)}$	$\overline{CEN}$	$\overline{BWx}$	$\overline{OE}$	I/O	Comments
n	X	X	L	H	L	X	X	?	Deselected.
n+1	X	X	L	H	L	X	X	?	Deselected.
n+2	A <sub>0</sub>	L	L	L	L	L	X	Z	Address and Control meet setup.
n+3	X	X	L	H	L	X	X	Z	Deselected or STOP.
n+4	A <sub>1</sub>	L	L	L	L	L	X	D <sub>0</sub>	Address D <sub>0</sub> Write in. Load A <sub>1</sub> .
n+5	X	X	L	H	L	X	X	Z	Deselected or STOP.
n+6	X	X	L	H	L	X	X	D <sub>1</sub>	Address D <sub>1</sub> Write in. Deselected.
n+7	A <sub>2</sub>	L	L	L	L	L	X	Z	Address and control meet setup.
n+8	X	X	L	H	L	X	X	Z	Deselected or STOP.
n+9	X	X	L	H	L	X	X	D <sub>2</sub>	Address D <sub>2</sub> Write in. Deselected.

5313 tbl 20

**NOTES:**

- 1 H = High; L = Low; X = Don't Care; ? = Don't Know; Z = High Impedance
- 2  $\overline{CE} = L$  is defined as  $\overline{CE}_1 = L$   $\overline{CE}_2 = L$  and  $CE_2 = H$   $\overline{CE} = H$  is defined as  $\overline{CE}_1 = H$   $\overline{CE}_2 = H$  or  $CE_2 = L$

### DC Electrical Characteristics Over the Operating Temperature and Supply Voltage Range (VDD = 2.5V±5%)

Symbol	Parameter	Test Conditions	Min.	Max.	Unit
I <sub>LI</sub>	Input Leakage Current	VDD = Max, VIN = 0V to VDD	—	5	μA
I <sub>LI</sub>	$\overline{\text{LBO}}$ , JTAG and ZZ Input Leakage Current <sup>(1)</sup>	VDD = Max, VIN = 0V to VDD	—	30	μA
I <sub>LO</sub>	Output Leakage Current	VOUT = 0V to VDD, Device Deselected	—	5	μA
VOL	Output Low Voltage	IOL = +6mA, VDD = Min	—	0.4	V
VOH	Output High Voltage	IOH = -6mA, VDD = Min	2.0	—	V

NOTE:

5313 tbl 21

1 The  $\overline{\text{LBO}}$ , TMS, TDI, TCK and  $\overline{\text{TRST}}$  pins will be internally pulled to VDD and the ZZ pin will be internally pulled to VSS if they are not actively driven in the application

### DC Electrical Characteristics Over the Operating Temperature and Supply Voltage Range<sup>(1)</sup> (VDD = 2.5V±5%)

Symbol	Parameter	Test Conditions	200MHz		166MHz		150MHz		133MHz		100MHz		Unit
			Com'l	Ind	Com'l	Ind	Com'l	Ind	Com'l	Ind	Com'l	Ind	
I <sub>DD</sub>	Operating Power Supply Current	Device Selected, Outputs Open ADV/ $\overline{\text{LD}}$ = X VDD = Max VIN ≥ VIH or ≤ VIL, f = fMAX <sup>(2)</sup>	275	295	245	265	215	235	195	215	175	195	mA
ISB1	CMOS Standby Power Supply Current	Device Deselected, Outputs Open, VDD = Max, VIN ≥ VHD or ≤ VLD f = 0 <sup>(2,3)</sup>	40	60	40	60	40	60	40	60	40	60	mA
ISB2	Clock Running Power Supply Current	Device Deselected, Outputs Open VDD = Max, VIN ≥ VHD or ≤ VLD f = fMAX <sup>(2,3)</sup>	80	100	70	90	60	80	50	70	45	65	mA
ISB3	Idle Power Supply Current	Device Selected, Outputs Open, $\overline{\text{CEN}} \geq \text{VH}$ , VDD = Max VIN ≥ VHD or ≤ VLD, f = fMAX <sup>(2,3)</sup>	60	80	60	80	60	80	60	80	60	80	mA
I <sub>ZZ</sub>	Full Sleep Mode Supply Current	Device Selected, Outputs Open, $\overline{\text{CEN}} \leq \text{VH}$ , VDD = Max VIN ≥ VHD or ≤ VLD, f = fMAX <sup>(2,3)</sup> , ZZ ≥ VHD	40	60	40	60	40	60	40	60	40	60	mA

NOTES:

5313 tbl 22

- All values are maximum guaranteed values
- At f = fMAX inputs are cycling at the maximum frequency of read cycles of 1/tcyc; f=0 means no input lines are changing
- For I/Os VHD = VDD - 0.2V VLD = 0.2V For other inputs VHD = VDD - 0.2V VLD = 0.2V

### AC Test Load

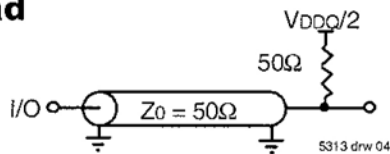

Figure 1. AC Test Load

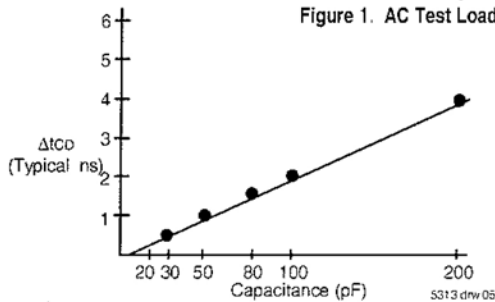

Figure 2. Lumped Capacitive Load, Typical Derating

### AC Test Conditions

Input Pulse Levels	0 to 2.5V
Input Rise/Fall Times	2ns
Input Timing Reference Levels	(VDDQ/2)
Output Timing Reference Levels	(VDDQ/2)
AC Test Load	See Figure 1

5313 tbl 23

## AC Electrical Characteristics (V<sub>DD</sub> = 2.5V +/-5%, Commercial and Industrial Temperature Ranges)

Symbol	Parameter	200MHz		166MHz		150MHz		133MHz		100MHz		Unit
		Min.	Max.	Min.	Max.	Min.	Max.	Min.	Max.	Min.	Max.	
t <sub>CYC</sub>	Clock Cycle Time	5	—	6	—	6.7	—	7.5	—	10	—	ns
f <sub>clk</sub> <sup>(1)</sup>	Clock Frequency	—	200	—	166	—	150	—	133	—	100	MHz
t <sub>CH</sub> <sup>(2)</sup>	Clock High Pulse Width	1.8	—	1.8	—	2.0	—	2.2	—	3.2	—	ns
t <sub>CL</sub> <sup>(2)</sup>	Clock Low Pulse Width	1.8	—	1.8	—	2.0	—	2.2	—	3.2	—	ns
<b>Output Parameters</b>												
t <sub>CD</sub>	Clock High to Valid Data	—	3.2	—	3.5	—	3.8	—	4.2	—	5	ns
t <sub>CDL</sub>	Clock High to Data Change	1.0	—	1.0	—	1.5	—	1.5	—	1.5	—	ns
t <sub>CLZ</sub> <sup>(3,4,5)</sup>	Clock High to Output Active	1.0	—	1.0	—	1.5	—	1.5	—	1.5	—	ns
t <sub>CHZ</sub> <sup>(3,4,5)</sup>	Clock High to Data High-Z	1.0	3	1.0	3	1.5	3	1.5	3	1.5	3.3	ns
t <sub>OE</sub>	Output Enable Access Time	—	3.2	—	3.5	—	3.8	—	4.2	—	5	ns
t <sub>OLZ</sub> <sup>(3,4)</sup>	Output Enable Low to Data Active	0	—	0	—	0	—	0	—	0	—	ns
t <sub>OHZ</sub> <sup>(3,4)</sup>	Output Enable High to Data High-Z	—	3.2	—	3.5	—	3.8	—	4.2	—	5	ns
<b>Set Up Times</b>												
t <sub>SE</sub>	Clock Enable Setup Time	1.4	—	1.5	—	1.5	—	1.7	—	2.0	—	ns
t <sub>SA</sub>	Address Setup Time	1.4	—	1.5	—	1.5	—	1.7	—	2.0	—	ns
t <sub>SD</sub>	Data In Setup Time	1.4	—	1.5	—	1.5	—	1.7	—	2.0	—	ns
t <sub>SW</sub>	Read/Write (R/W) Setup Time	1.4	—	1.5	—	1.5	—	1.7	—	2.0	—	ns
t <sub>SADV</sub>	Advance/Load (ADV/LD) Setup Time	1.4	—	1.5	—	1.5	—	1.7	—	2.0	—	ns
t <sub>SC</sub>	Chip Enable/Select Setup Time	1.4	—	1.5	—	1.5	—	1.7	—	2.0	—	ns
t <sub>SB</sub>	Byte Write Enable (BWx) Setup Time	1.4	—	1.5	—	1.5	—	1.7	—	2.0	—	ns
<b>Hold Times</b>												
t <sub>HE</sub>	Clock Enable Hold Time	0.4	—	0.5	—	0.5	—	0.5	—	0.5	—	ns
t <sub>HA</sub>	Address Hold Time	0.4	—	0.5	—	0.5	—	0.5	—	0.5	—	ns
t <sub>HD</sub>	Data In Hold Time	0.4	—	0.5	—	0.5	—	0.5	—	0.5	—	ns
t <sub>HW</sub>	Read/Write (R/W) Hold Time	0.4	—	0.5	—	0.5	—	0.5	—	0.5	—	ns
t <sub>HADV</sub>	Advance/Load (ADV/LD) Hold Time	0.4	—	0.5	—	0.5	—	0.5	—	0.5	—	ns
t <sub>HC</sub>	Chip Enable/Select Hold Time	0.4	—	0.5	—	0.5	—	0.5	—	0.5	—	ns
t <sub>HB</sub>	Byte Write Enable (BWx) Hold Time	0.4	—	0.5	—	0.5	—	0.5	—	0.5	—	ns

## NOTES:

5313 tbl 24

- 1 f = 1/t<sub>CYC</sub>
- 2 Measured as HIGH above 0.6V<sub>DD</sub> and LOW below 0.4V<sub>DD</sub>.
- 3 Transition is measured ±200mV from steady-state
- 4 These parameters are guaranteed with the AC load (Figure 1) by device characterization. They are not production tested.
- 5 To avoid bus contention, the output buffers are designed such that t<sub>CHZ</sub> (device turn-off) is faster than t<sub>CLZ</sub> (device turn-on) at a given temperature and voltage. The specs as shown do not imply bus contention because t<sub>CLZ</sub> is a Min. parameter that is worse case at totally different test conditions (0 deg C, 2.625V) than t<sub>CHZ</sub> which is a Max. parameter (worse case at 70 deg C, 2.375V)

### Timing Waveform of Read Cycle<sup>(1,2,3,4)</sup>

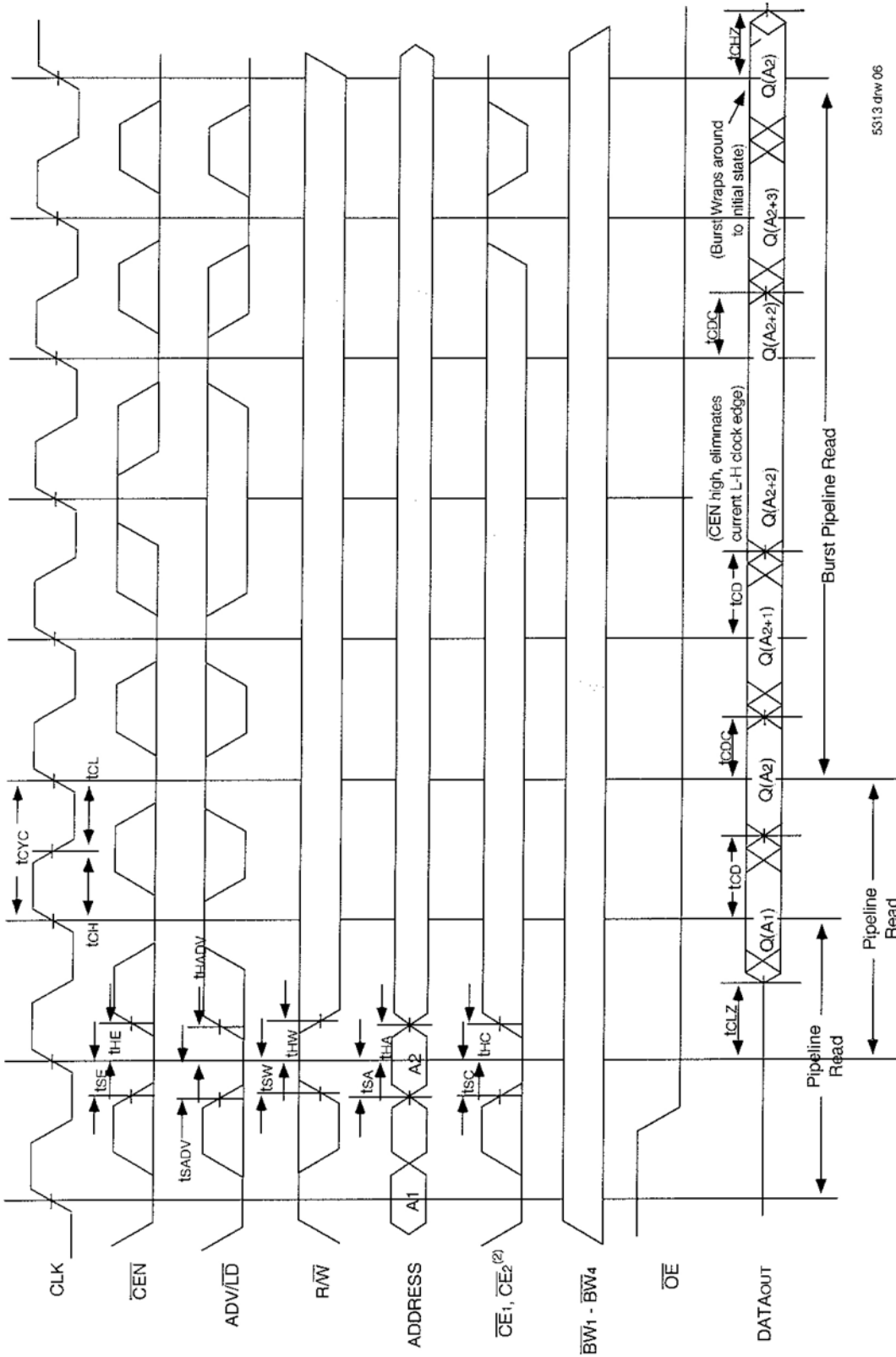

5313 drw 06

**NOTES:**

1.  $Q(A_1)$  represents the first output from the external address  $A_1$ .  $Q(A_2)$  represents the first output from the external address  $A_2$ ;  $Q(A_2+1)$  represents the next output data in the burst sequence of the base address  $A_2$ , etc. where address bits  $A_0$  and  $A_1$  are advancing for the four word burst in the sequence defined by the state of the LBO input.
2.  $CE_2$  timing transitions are identical but inverted to the  $CE_1$  and  $CE_2$  signals. For example, when  $CE_1$  and  $CE_2$  are LOW on this waveform,  $CE_2$  is HIGH.
3. Burst ends when new address and control are loaded into the SRAM by sampling  $ADV/LD$  LOW.
4.  $R/W$  is don't care when the SRAM is bursting ( $ADV/LD$  sampled HIGH). The nature of the burst access (Read or Write) is fixed by the state of the  $R/W$  signal when new address and control are loaded into the SRAM.







## Timing Waveform of CEN Operation(1,2,3,4)

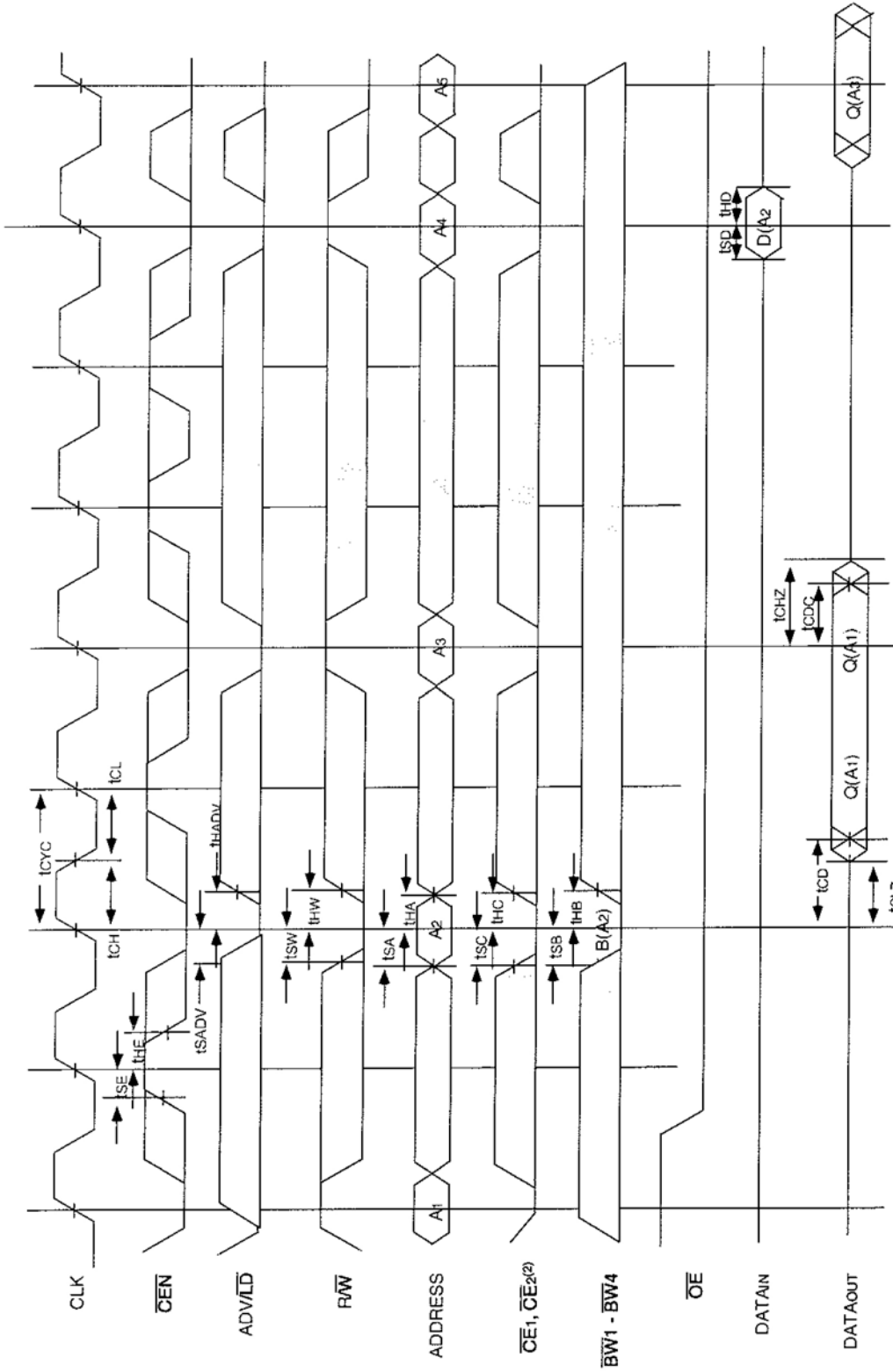

5313 drw 09

**NOTES:**

1. Q(A1) represents the first output from the external address A1. D(A2) represents the input data to the SRAM corresponding to address A2.
2. CE2 timing transitions are identical but inverted to the CE1 and CE2 signals. For example, when CE1 and CE2 are LOW on this waveform, CE2 is HIGH.
3. CEN when sampled high on the rising edge of clock will block that L-H transition of the clock from propagating into the SRAM. The part will behave as if the L-H clock transition did not occur. All internal registers in the SRAM will retain their previous state.
4. Individual Byte Write signals (BWx) must be valid on all write and burst-write cycles. A write cycle is initiated when RW signal is sampled LOW. The byte write information comes in two cycles before the actual data is presented to the SRAM.

### Timing Waveform of $\overline{CS}$ Operation<sup>(1,2,3,4)</sup>

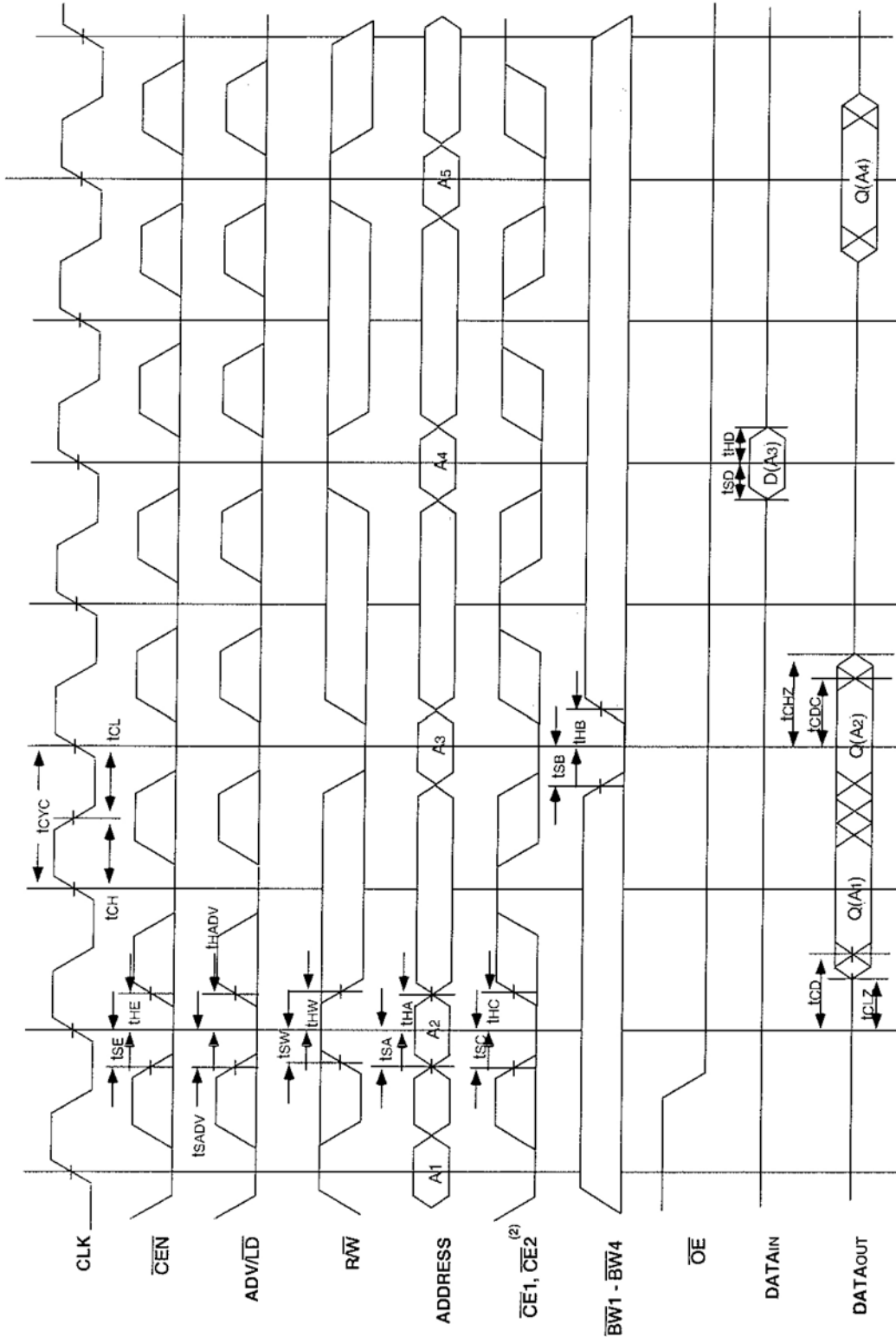

5313 d/w 10

**NOTES:**

1. Q(A1) represents the first output from the external address A1. D(A3) represents the input data to the SRAM corresponding to address A3.
2. CE2 timing transitions are identical but inverted to the CE1 and CE2 signals. For example, when CE1 and CE2 are LOW on this waveform, CE2 is HIGH.
3. CEN when sampled high on the rising edge of clock will block that L-H transition of the clock from propagating into the SRAM. The part will behave as if the L-H clock transition did not occur. All internal registers in the SRAM will retain their previous state.
4. Individual Byte Write signals (BWx) must be valid on all write and burst-write cycles. A write cycle is initiated when RW signal is sampled LOW. The byte write information comes in two cycles before the actual data is presented to the SRAM.

## JTAG Interface Specification

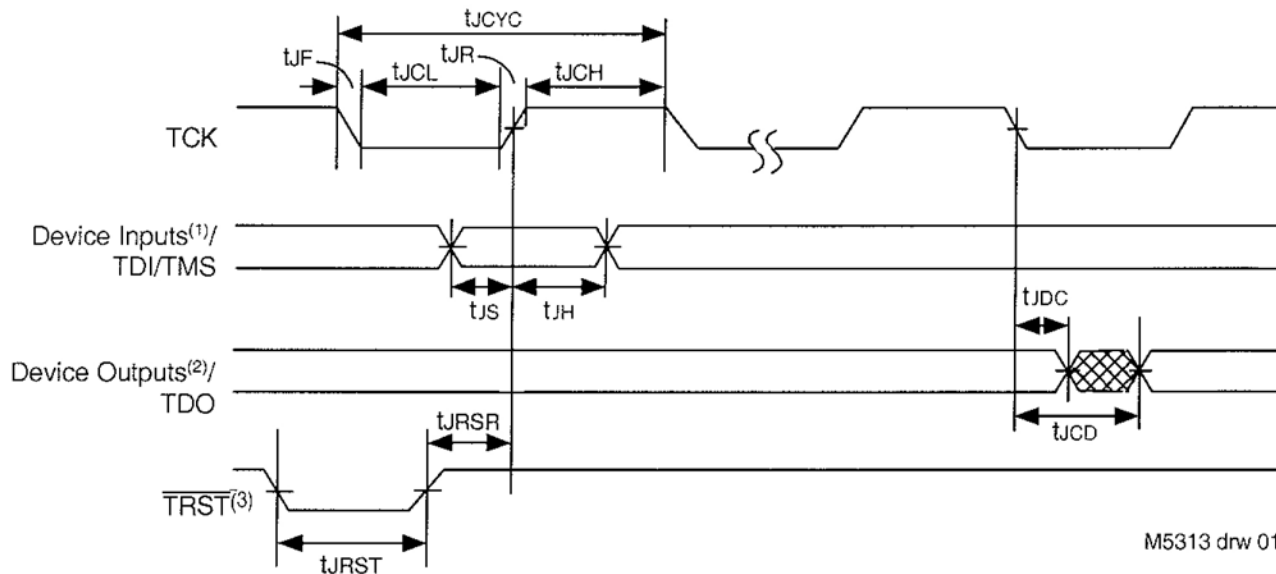

**NOTES:**

- 1 Device inputs = All device inputs except TDI, TMS and  $\overline{TRST}$
- 2 Device outputs = All device outputs except TDO
- 3 During power up,  $\overline{TRST}$  could be driven low or not be used since the JTAG circuit resets automatically  $\overline{TRST}$  is an optional JTAG reset

## JTAG AC Electrical Characteristics<sup>(1,2,3,4)</sup>

Symbol	Parameter			
		Min.	Max.	Units
$t_{JCYC}$	JTAG Clock Input Period	100	—	ns
$t_{JCH}$	JTAG Clock HIGH	40	—	ns
$t_{JCL}$	JTAG Clock Low	40	—	ns
$t_{JR}$	JTAG Clock Rise Time	—	5 <sup>(1)</sup>	ns
$t_{JF}$	JTAG Clock Fall Time	—	5 <sup>(1)</sup>	ns
$t_{JRST}$	JTAG Reset	50	—	ns
$t_{JRSR}$	JTAG Reset Recovery	50	—	ns
$t_{JCD}$	JTAG Data Output	—	20	ns
$t_{JDC}$	JTAG Data Output Hold	0	—	ns
$t_{JS}$	JTAG Setup	25	—	ns
$t_{JH}$	JTAG Hold	25	—	ns

M5313 tbl 01

## Scan Register Sizes

Register Name	Bit Size
Instruction (IR)	4
Bypass (BYR)	1
JTAG Identification (JIDR)	32
Boundary Scan (BSR)	Note (1)

M5313 tbl 03

**NOTE:**

- 1 The Boundary Scan Descriptive Language (BSDL) file for this device is available

**NOTES:**

- 1 Guaranteed by design
- 2 AC Test Load (Fig. 1) on external output signals
- 3 Refer to AC Test Conditions stated earlier in this document
- 4 JTAG operations occur at one speed (10MHz). The base device may run at any speed specified in this datasheet

## JTAG Identification Register Definitions

Instruction Field	Value	Description
Revision Number (31:28)	0x2	Reserved for version number.
IDT Device ID (27:12)	0x220, 0x222	Defines part number AS8C163631 and AS8C161831, respectively
IDT JEDEC ID (11:1)	0x33	Allows unique identification of device vendor
ID Register Indicator Bit (Bit 0)	1	Indicates the presence of an ID register

5313 tbl 02

## Available JTAG Instructions

Instruction	Description	OPCODE
EXTEST	Forces contents of the boundary scan cells onto the device outputs <sup>(1)</sup> Places the boundary scan register (BSR) between TDI and TDO	0000
SAMPLE/PRELOAD	Places the boundary scan register (BSR) between TDI and TDO SAMPLE allows data from device inputs <sup>(2)</sup> and outputs <sup>(1)</sup> to be captured in the boundary scan cells and shifted serially through TDO PRELOAD allows data to be input serially into the boundary scan cells via the TDI	0001
DEVICE_ID	Loads the JTAG ID register (JIDR) with the vendor ID code and places the register between TDI and TDO	0010
HIGHZ	Places the bypass register (BYR) between TDI and TDO Forces all device output drivers to a High-Z state	0011
RESERVED	Several combinations are reserved. Do not use codes other than those identified for EXTEST, SAMPLE/PRELOAD, DEVICE_ID, HIGHZ, CLAMP, VALIDATE and BYPASS instructions	0100
RESERVED		0101
RESERVED		0110
RESERVED		0111
CLAMP	Uses BYR Forces contents of the boundary scan cells onto the device outputs Places the bypass register (BYR) between TDI and TDO	1000
RESERVED	Same as above	1001
RESERVED		1010
RESERVED		1011
RESERVED		1100
VALIDATE	Automatically loaded into the instruction register whenever the TAP controller passes through the CAPTURE-IR state. The lower two bits '01' are mandated by the IEEE std 1149.1 specification	1101
RESERVED	Same as above	1110
BYPASS	The BYPASS instruction is used to truncate the boundary scan register as a single bit in length	1111

5313 tbl 04

### NOTES:

- 1 Device outputs = All device outputs except TDO
- 2 Device inputs = All device inputs except TDI, TMS and TRST.

# 100-Pin Thin Quad Flatpack (TQFP) Package Diagram Outline

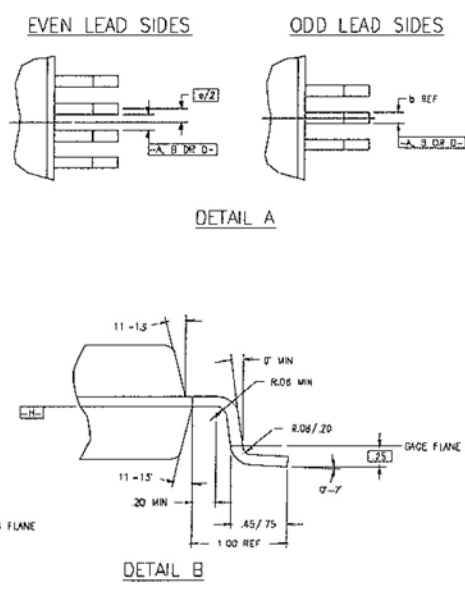
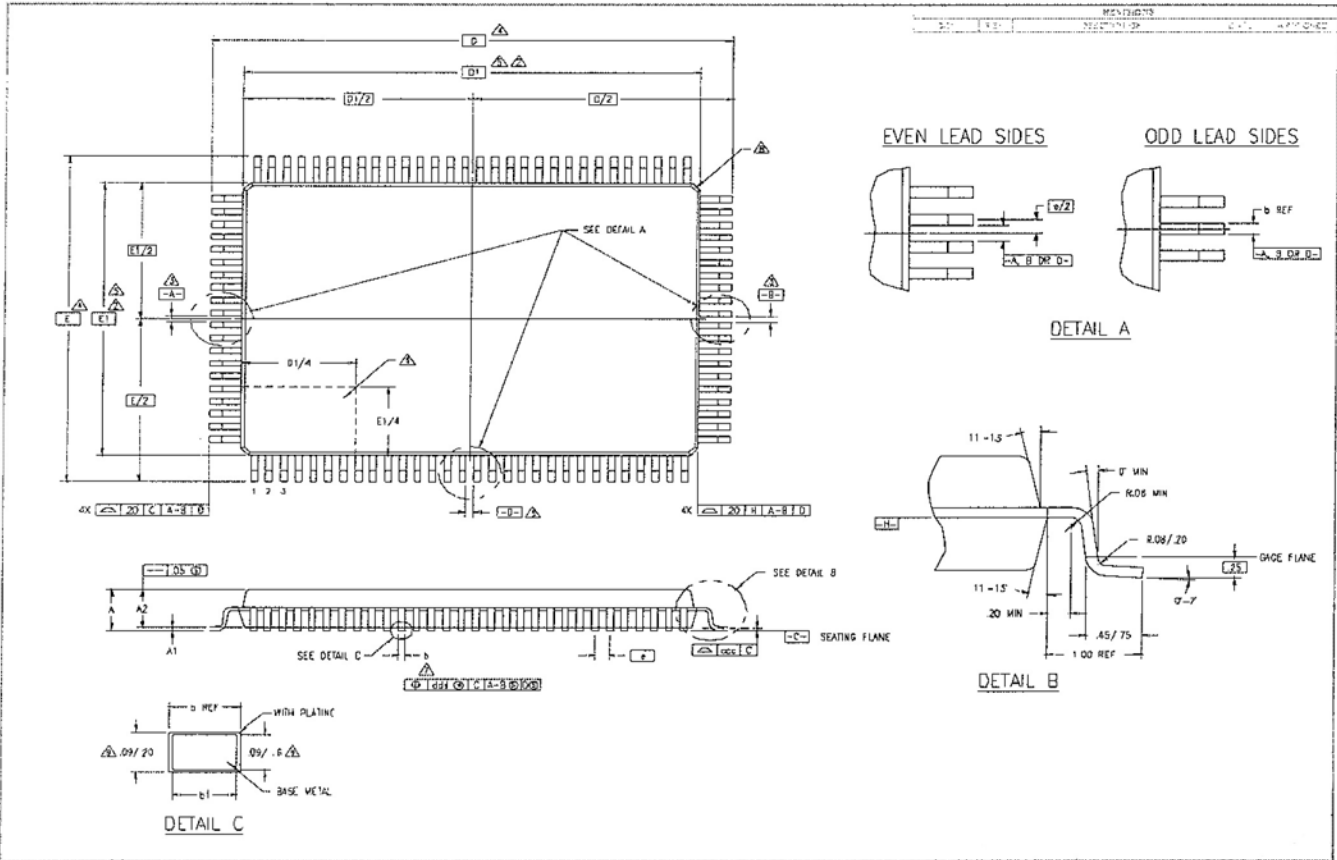

SYMBOL	JEDEC VARIATION			PITCH
	MIN	NOM	MAX	
A	-	-	1.60	
A1	.05	.10	.15	
A2	1.35	1.40	1.45	
D	22.00 BSC			4
D1	20.00 BSC			5.2
E	16.00 BSC			4
E1	14.00 BSC			5.2
N	100			
NO	30			
NE	20			
e	65 BSC			
b	.22	.32	.38	7
b1	.22	.30	.35	
ccc	-	-	10	
ddd	-	-	1.3	

**NOTES:**

- ALL DIMENSIONING AND TOLERANCING CONFORM TO ANSI Y14.5M-1982
- TOP PACKAGE MAY BE SMALLER THAN BOTTOM PACKAGE BY .15 mm
- DATUMS [A-B] AND [D-E] TO BE DETERMINED AT DATUM PLANE [H-H]
- DIMENSIONS D AND E ARE TO BE DETERMINED AT SEATING PLANE [C-C]
- DIMENSIONS D1 AND E1 DO NOT INCLUDE MOLD PROTRUSION. ALLOWABLE MOLD PROTRUSION IS .25 mm PER SIDE. D1 AND E1 ARE MAXIMUM BODY SIZE DIMENSIONS INCLUDING MOLD MISMATCH
- DETAILS OF PIN 1 IDENTIFIER IS OPTIONAL BUT MUST BE LOCATED WITHIN THE ZONE INDICATED
- DIMENSION D DOES NOT INCLUDE DAMBAR PROTRUSION. ALLOWABLE DAMBAR PROTRUSION IS .38 mm IN EXCESS OF THE b DIMENSION AT MAXIMUM MATERIAL CONDITION. DAMBAR CANNOT BE LOCATED ON THE LOWER RADIUS OR THE FOOT.
- EXACT SHAPE OF EACH CORNER IS OPTIONAL
- THESE DIMENSIONS APPLY TO THE FLAT SECTION OF THE LEAD BETWEEN .10 AND .25 mm FROM THE LEAD TIP
- ALL DIMENSIONS ARE IN MILLIMETERS
- THIS OUTLINE CONFORMS TO JEDEC PUBLICATION 95 REGISTRATION MO-138 VARIATION QJ AND BX

**LAND PATTERN DIMENSIONS**

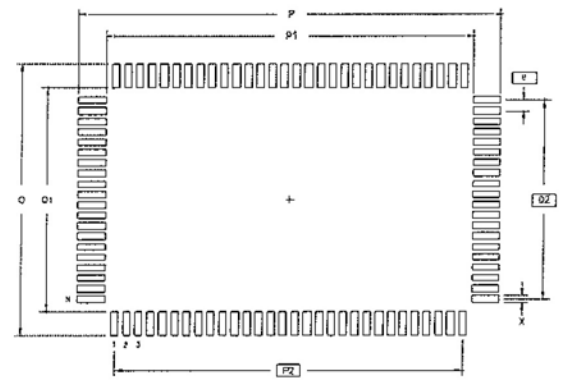

	MIN	MAX
P	22.80	23.00
P1	19.80	20.00
P2	18.65 BSC	
O	16.80	17.00
O1	13.80	14.00
O2	12.35 BSC	
X	.30	.50
e	65 BSC	
N	100	

## Timing Waveform of $\overline{OE}$ Operation<sup>(1)</sup>

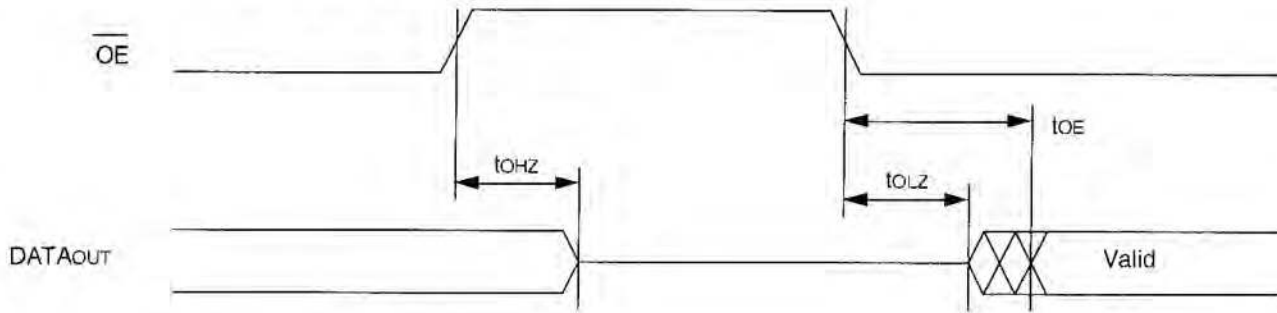

5313 drw 11

**NOTE:**

1 A read operation is assumed to be in progress

## ORDERING INFORMATION

Alliance	Organization	VCC Range	Package	Operating Temp	Speed Mhz
AS8C163631-QC166N	512K x 36	2.3 - 2.6V	100 pin TQFP	Comercial: 0 - 70C	166
AS8C161831-QC166N	1M x 18	2.3 - 2.6V	100 pin TQFP	Comercial: 0 - 70C	166

## PART NUMBERING SYSTEM

AS8C	Device	Conf.	Mode	Package	Operating Temp	Speed	N
Sync. SRAM prefix	16 = 16M	18= x18 36 = x36	01 = ZBT 00 = Pipelined 25 = Flow- Thru 31 = ZBT (Pipelined)	Q = 100 Pin TQFP	0 ~ 70C	166MHz	N= Leadfree



Alliance Memory, Inc.  
551 Taylor Way, Suite #1  
San Carlos, CA 94070  
Tel: 650-610-6800  
Fax: 650-620-9211

www.alliancememory.com

Copyright © Alliance Memory  
All Rights Reserved  
Part Number: AS8C163631/1831  
Document Version: v. 1.0