

DC626A-A, LTC1569-6
DC626A-B, LTC1569-7

DESCRIPTION

The LTC1569-6 and LTC1569-7 are monolithic 10th order linear phase low pass filters. These are the first sampled data filters in the industry to provide accurate control of the cutoff frequency without the need for an external clock. Offered in the 8-lead SOIC package, the LTC1569 family is tunable with a single resistor. The LTC1569's ease of use, accurate tuning and small package combined with its precision performance and high selectivity is practically impossible to achieve with discrete components. Its root raised cosine gain response and linear phase results in excellent lowpass characteristics with steep selectivity ideal for use in data communication and data acquisition systems

LTC is a trademark of Linear Technology Corporation

The filter attenuation is 50dB at 1.5 times the filter cut-off and 80dB at 6 times the cutoff frequency. Thus, the LTC1569 family is an excellent choice in applications with demanding specifications for rejection of frequency components outside the passband. With up to 300kHz cutoff, the LTC1569-7 is intended for systems needing maximum bandwidth whereas the LTC1569-6 offers a low power solution with consumption as low as 8mW ($f_c = 4\text{kHz}$). Operating from 3V to $\pm 5\text{V}$ supplies, the LTC1569-6 and LTC1569-7 are available in the 8-pin SOIC package.

**Design files for this circuit board are available.
Call the LTC factory.**

Figure 1. Demo Circuit Board 626A-A

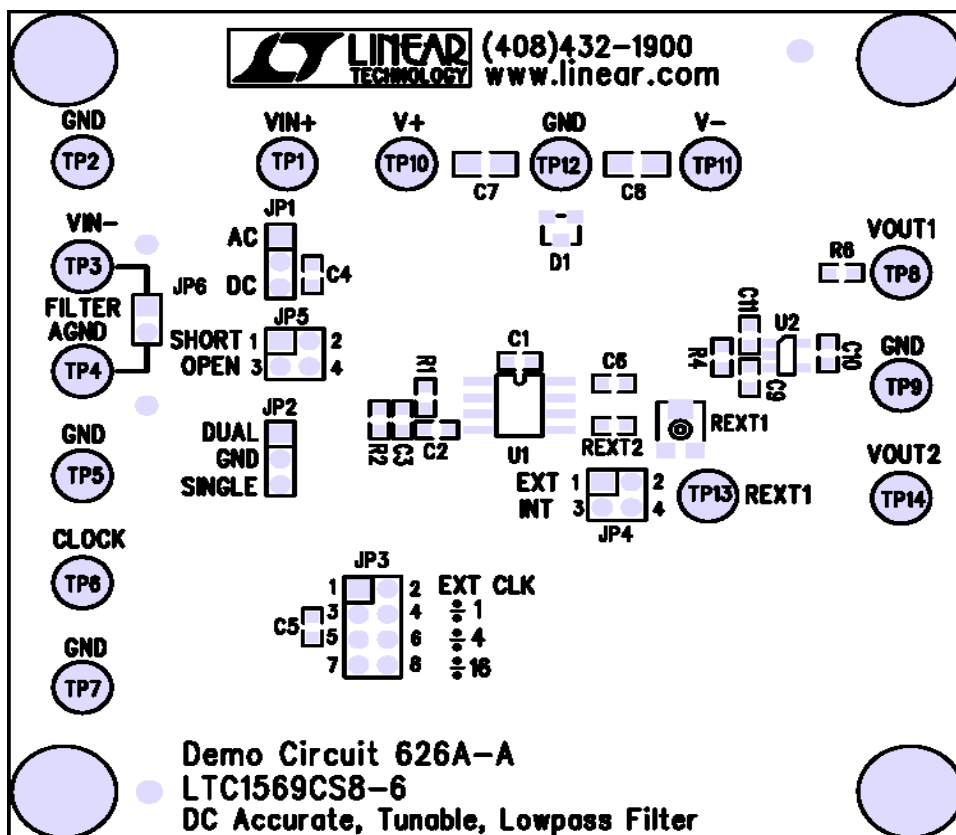

Note: U1 on Demo Circuit 626A-A is an LTC1569-6.
Demo Circuit 626A-B is the same as 626A-A except for an LTC1569-7 installed as U1.

LTC1569-6 and LTC1569-7 Equations

(Calculating the value of the external resistance that sets the internal clock frequency)

FCUTOFF is the -3dB Frequency

REXT is the resistance value connected from pin 7 to pin 6

N is the internal divider value, **N = 1, 4 or 16**

LTC1569-6

FCUTOFF = (64kHz / N)•(10k / REXT), REXT in k

REXT = (64kHz / FCUTOFF)•(10k / N), FCUTOFF in kHz

IF (64kHz / FCUTOFF) < 4 THEN N = 1

IF 4 ≤ (64kHz / FCUTOFF) < 16 THEN N = 4

IF 16 ≤ (64kHz / FCUTOFF) THEN N = 16

LTC1569-7

FCUTOFF = (128kHz / N)•(10k / REXT), REXT in k

REXT = (128kHz / FCUTOFF)•(10k / N), FCUTOFF in kHz

IF (128kHz / FCUTOFF) < 4 THEN N = 1

IF 4 ≤ (128kHz / FCUTOFF) < 16 THEN N = 4

IF 16 ≤ (128kHz / FCUTOFF) THEN N = 16

Calculation procedure for setting the value of potentiometer REXT1

1. **A.** For an LTC1569-6 (DC626A-A), calculate (64kHz / FCUTOFF) and select N
B. For an LTC1569-7 (DC626A-B), calculate (128kHz / FCUTOFF) and select N
2. **A.** For an LTC1569-6, calculate REXT = (64kHz / FCUTOFF)•(10k / N)
B. For an LTC1569-7, calculate REXT = (128kHz / FCUTOFF)•(10k / N)
3. Calculate the value of potentiometer REXT1, REXT1 = (REXT - 3.4k)

Example: Set REXT1 for FCUTOFF = 16kHz

STEP 1. **A.** N=4 for an LTC1569-6, (64kHz / 16kHz)=4 and
B. N=4 for an LTC1569-7, (128kHz / 16kHz)=8

STEP 2. **A.** REXT for LTC1569-6 = [640kHz / (16kHz • 4)]k=10k and
B. REXT for LTC1569-7 = [1280kHz / (16kHz • 4)]k=20k

STEP 3. REXT1 for LTC1569-6 = [10k - 3.4k]= 6.6k and
REXT1 for LTC1569-7 = [20k - 3.4k]=16.6k

The Frequency Of The External Clock, FCLOCK (Pin 6 connected to V-)

LTC1569-6 FCLOCK = 64x FCUTOFF

LTC1569-7 FCLOCK = 32x FCUTOFF

Figure 2. A Dual Power Supply Circuit with External Clock Source

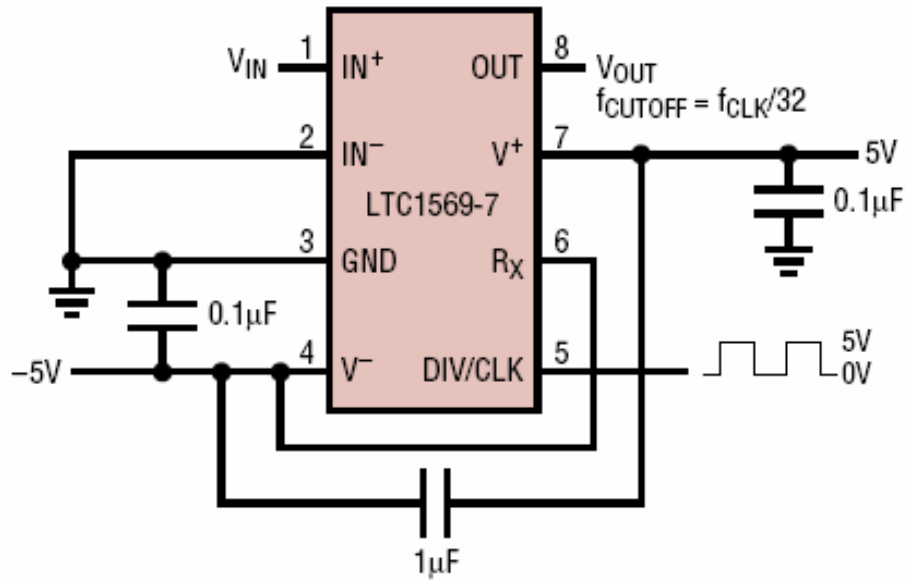

Figure 3. A Single Power Supply Circuit with Internal Clock Source

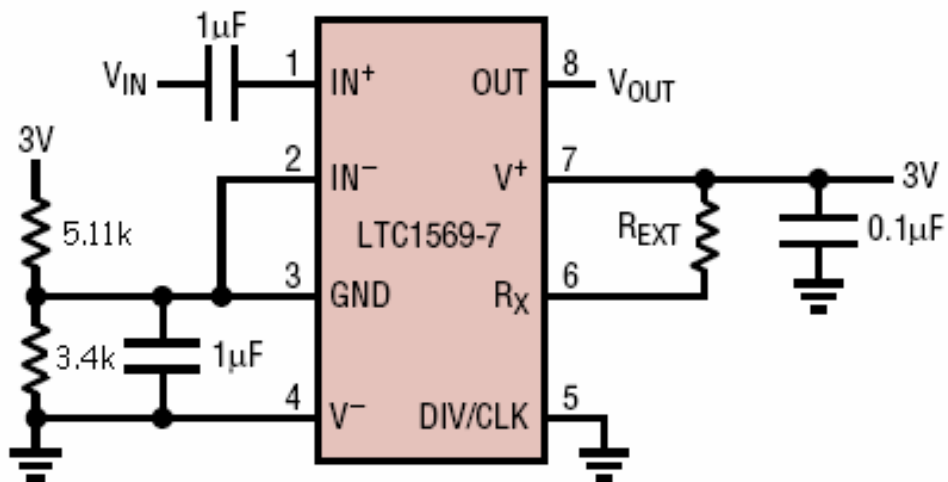
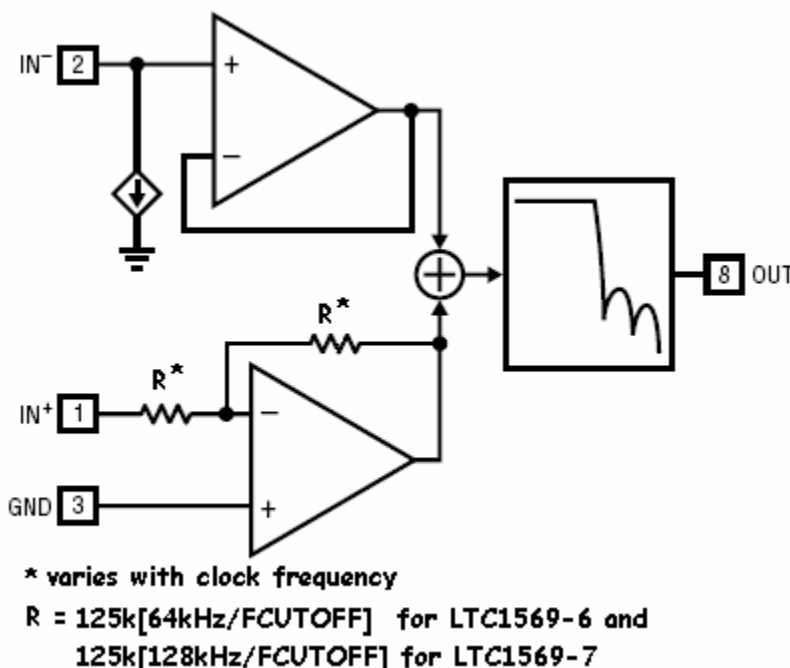

Figure 4. LTC1569-6/7 Block Diagram



LTC1569-6/7 Input and Output Considerations.

The filter's output (pin 8) can drive 10k and/or 40pF loads. On a DC626A, the filter's output is connected to VOUT1 (TP8) thru a 10Ω resistor so that the filter's output will not drive directly a capacitive load greater than 40pF (capacitive loads greater than 40pF increase the output DC offset and AC distortion).

However, for convenience all DC626A measurements can be reliably made thru the buffered output at VOUT2.

Figures 2 and 3 show typical LTC1569-7 circuits using dual or single power supplies
 (For an LTC1569-6, $f_{CUTOFF} = f_{CLK}/64$ otherwise the Figures 2 and 3 circuits are identical for an LTC1569-6).

If $f_{CUTOFF} \geq 0.5kHz$ for an LTC1569-6 or $f_{CUTOFF} \geq 1kHz$ for an LTC1569-7 ($REXT \leq 81k$) then an external clock is not needed for a fixed cutoff frequency (not clock tunable)

DC626A-A and DC626A-B Jumper Shunt Settings

- JP1: DC or AC input signal coupling
- JP2: DUAL or SINGLE supply operation
- JP3: Connects an EXT CLK to pin 5 or sets pin 5 for divide by 1, 4 or 16 of the internal clock (set by REXT)
- JP4: Pin 6 is set for an internal clock (INT) or an external clock (EXT)
- JP5: Normally to OPEN, for measuring the filter's output DC voltage pin 1 is shorted to pin 3 (JP5 to SHORT).
- JP6: Normally shorts the -IN input (pin 2) to FILTER AGND (pin 3) to provide for a single-ended to the +IN input (pin 1).

For a fixed cutoff frequency with a differential input, if the input impedance at IN- must be matched to the input impedance at IN+ then connect optional resistor R3 from VIN- to FILTER AGND (remove shunt on JP6 shorting TP3 to TP4). The value of R3 depends on the clock frequency and is equal to $62.5k \cdot [64 kHz/f_{CUTOFF}]$ for an LTC1569-6 or equal to $62.5k \cdot [128 kHz/f_{CUTOFF}]$ for an LTC1569-7 (see Figure 4 block diagram).

Figure 5. A Dual Power Supply Measurement Setup

(JP1 to DC, JP2 to DUAL, JP3 to EXT CLK, JP4 to EXT, JP5 OPEN, JP6 SHORT)

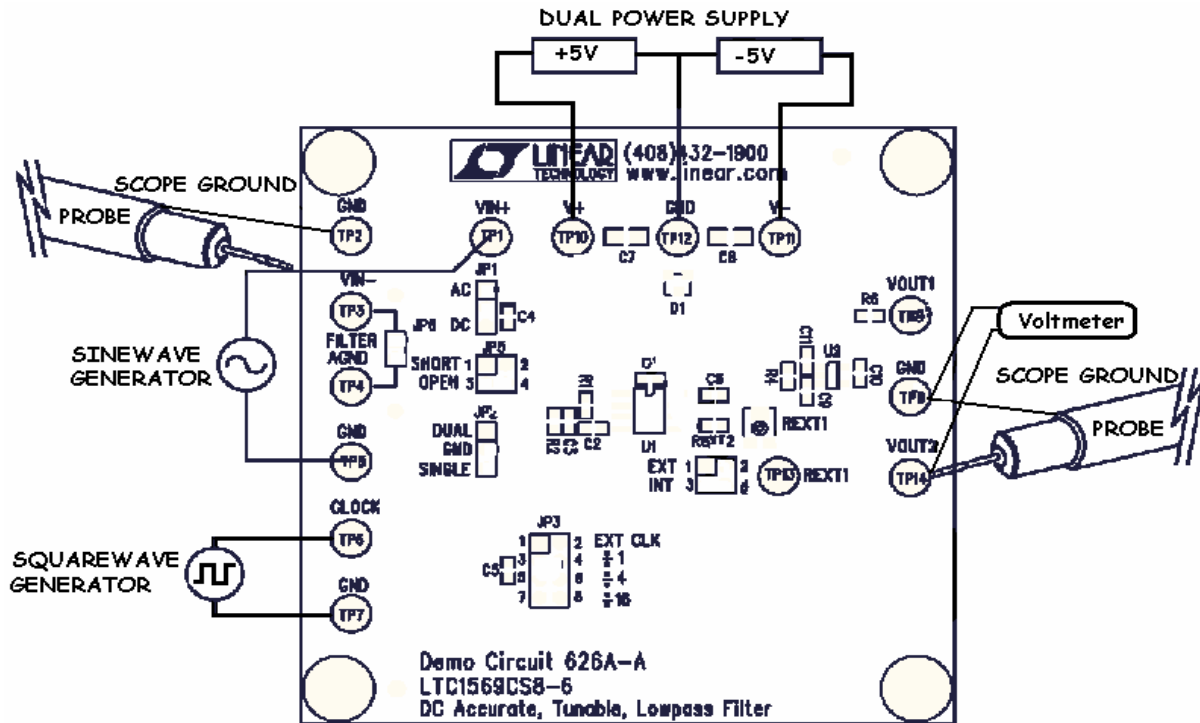
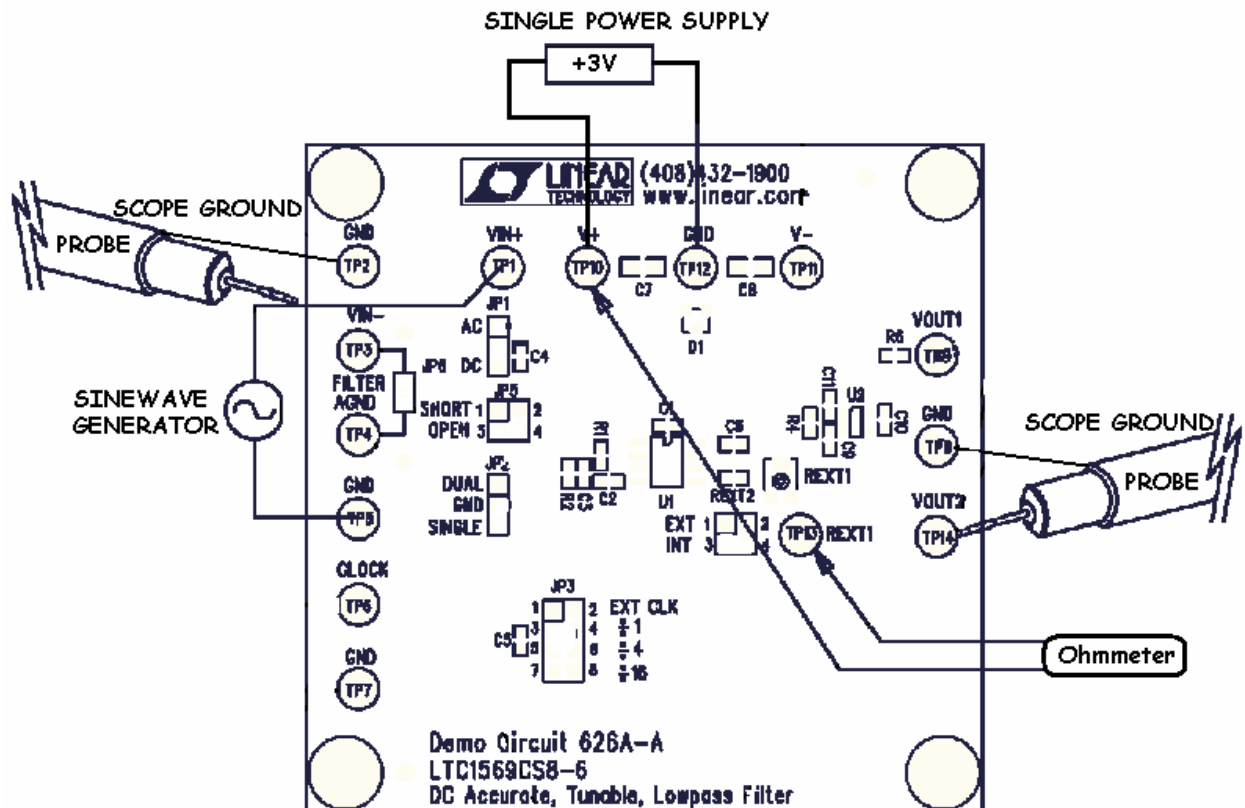

Figure 6. A Single Power Supply Measurement Setup

(JP1 to AC, JP2 to SINGLE, JP3 to $\div 1$, JP4 to INT, JP5 OPEN, JP6 SHORT)



QUICK TEST PROCEDURE

1. Dual Power Supply Circuit with an External Clock

a. Filter Output DC Offset

1. Set the DC626A-A (LTC1569-6) or DC626A-B (LTC1569-7) board jumpers:
JP1 to DC, JP2 to DUAL, JP3 to EXT CLK, JP4 to EXT, JP5 OPEN, JP6 SHORT.
2. Use Figure 5 as guide to connect a dual power supply, squarewave generator, oscilloscope and voltmeter.
3. Set dual power supply to $\pm 5V$ and turn it on.
4. Turn on the generator which has been preset to output a 0V to 5V, 4.096MHz squarewave and turn it on.
(A [0V to V+] external clock can be used with a single or a dual power supply). With a 4.096MHz clock, the Fcutoff for an LTC1569-6 is 64kHz and for an LTC1569-7 is 128kHz.
5. The voltmeter reading should be $\pm 15mV$ typically (a maximum DC offset is not specified with a $\pm 5V$ supply).

b. Filter Gain Response

1. Set JP5 to OPEN.
2. Connect sinewave generator output to VIN+ (TP1) and generator ground to TP5.
3. Turn on the sinewave generator which has been preset to output a 1kHz, 1V p-p sinewave.
4. A 1kHz, 1V p-p sinewave should be shown on the oscilloscope connected to VOUT2.
An input 1kHz, 1V p-p sinewave signal is in filter's passband and should appear at the filter's output.
5. Set the generator to an input signal in the filter's stopband:
 - A. 100kHz, 1V p-p sinewave for an LTC1569-6
 - B. 200kHz, 1V p-p sinewave for an LTC1569-7
6. The output signal should be less than 3mV p-p (attenuated by at least 50dB).

2. Single Power Supply Circuit with an Internal Clock

a. Filter Output DC Offset

1. Set the DC626A-A (LTC1569-6) or DC626A-B (LTC1569-7) board jumpers:
JP1 to AC, JP2 to SINGLE, JP3 to $\div 1$, JP4 to INT, JP5 OPEN, JP6 SHORT
2. Use Figure 6 as guide to connect a single power supply, sinewave generator, oscilloscope and ohmmeter.
3. Set REXT 1 to 6.6k and remove ohmmeter
(with REXT1 equal to 6.6k the total resistance from pin 6 to 7 is equal to 10k and if pin 5 is set for $\div 1$ (JP3 3-4) then the Fcutoff for an LTC1569-6 is 64kHz and the Fcutoff for an LTC1569-7 is 128kHz).
4. Turn on the power supply which has been set to output 3V.
5. Use a voltmeter to measure the voltage from VOUT2, TP14 to GND, TP9.
The voltage reading should be 1.20V, $\pm 25mV$ (equal to the pin 3 voltage if $V+=3.0V$).
6. Connect voltmeter from VOUT2, TP14 to FILTER AGND, TP4
(this is the filter's DC offset for a single supply).
7. The voltmeter reading should be a maximum DC offset of $\pm 5mV$
(the voltage offset of U2 buffer is a maximum of 0.3mV).

b. Filter Gain Response

1. Set JP5 to OPEN.
2. Connect sinewave generator output to VIN+ (TP1) and generator ground to TP5.
3. Turn on the sinewave generator which has been set to output a 1kHz, 1V p-p sinewave.
4. A 1kHz, 1V p-p sinewave should be shown on the oscilloscope connected to VOUT2.
A 1kHz, 1V p-p sinewave signal is in filter's passband and should appear at the filter's output.
5. Set the generator to an input signal in the filter's stopband:
 - A. 100kHz, 1V p-p sinewave for an LTC1569-6
 - B. 200kHz, 1V p-p sinewave for an LTC1569-7
6. The output signal should be less than 3mV p-p (attenuated by at least 50dB).

Figure 7. DC626A-A Schematic

(Schematic for DC626A-B is the same as the DC626A-A except for U1 which is an LTC1569CS8-7)

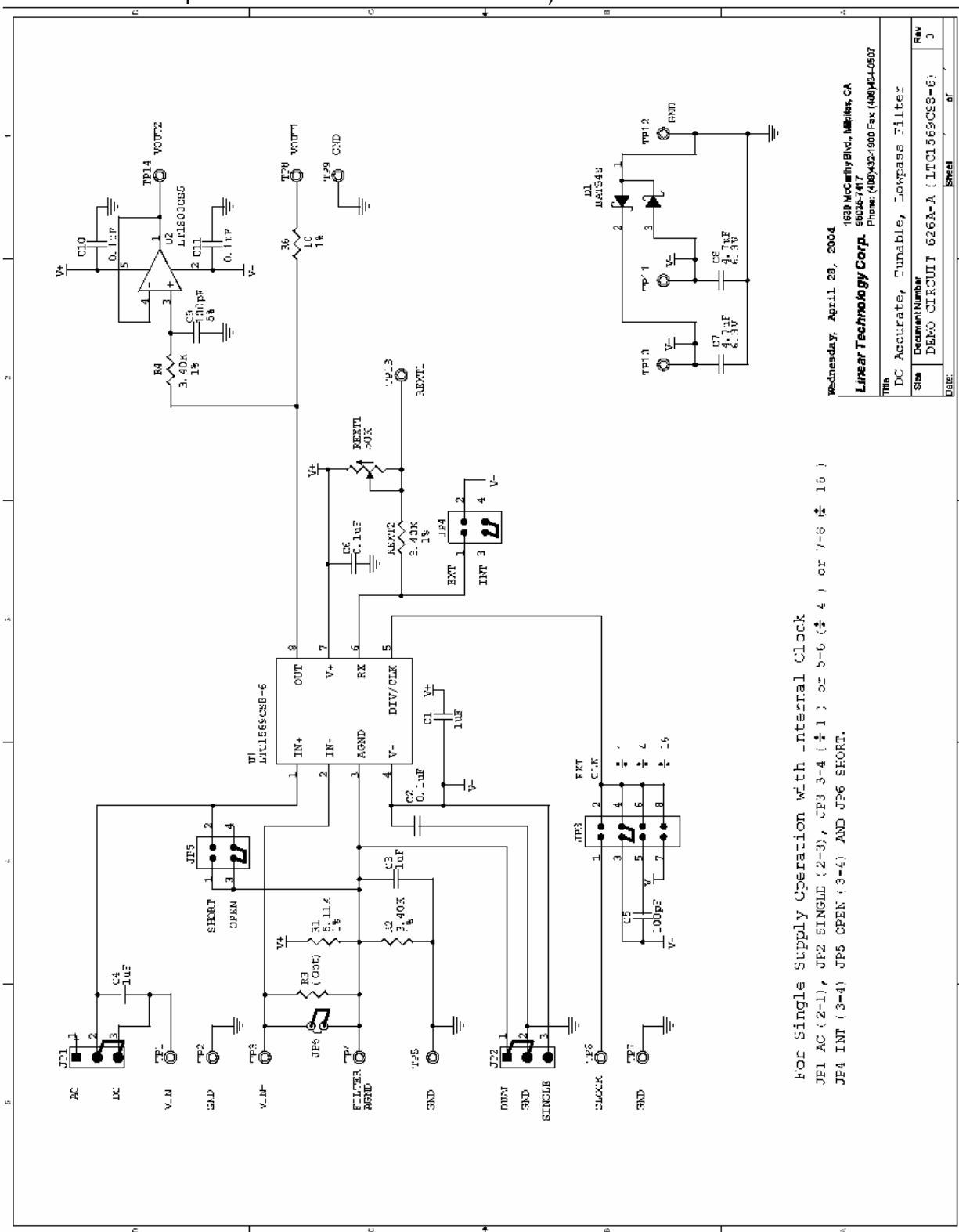

For Single Supply Operation with internal clock
 JF1 AC (2-1), JF2 SINGLE (2-3), CF3 3-4 (1/2 1) or 5-6 (1/2 4) or 7-8 (1/2 16)
 JF4 INT (3-4) JF5 OPEN (3-4) AND JF6 SHORT.

Wednesday, April 11, 2004
 1630 McCarty Blvd., Milpitas, CA
 95035-7417
 Phone: (408)432-1900 Fax: (408)432-0907
Linear Technology Corp.
 DC Accurate, Tunable, Lowpass Filter

Doc#	DC626A-A	Rev	3
Doc#	DC626A-A	Rev	3
Doc#	DC626A-A	Rev	3

Table 3. DC626A-A Parts List

(Parts list for DC626A-B is the same as the DC626A-A except for U1 which is an LTC1569CS8-7)

<i>Iter</i>	<i>Qty</i>	<i>Reference</i>	<i>Part Description</i>	<i>Manufacture / Part #</i>
1	3	C1,C3,C4	Cap., X5R 1uF 10V 20%	Taiyo Yuden LMK107BJ105MA
2	4	C2,C6,C10,C11	Cap., X7R 0.1uF 16V 20%	Taiyo Yuden EMK107BJ104MA
3	1	C5	Cap., X7R 100pF 25V 10%	AVX 06033C101KAT2A
4	2	C8,C7	Cap., X5R 4.7uF 6.3V 20%	Taiyo Yuden JMK212BJ475MG-T
5	1	C9	Cap, NPO 100pF 25V 5%	AVX 06033A101JAT2A
6	1	D1	Diode Schottky (Dual) BAT54S	Zetex BAT54S
7	2	JP2,JP1	Headers, 3 Pins 2mm Ctrs.	Commcon Conn. Inc. 2802S-03G2
8	1	JP3	Headers, 2mm Ctrs.	Commcon Conn. Inc. 2202S-08G2
9	2	JP5,JP4	Headers, 2mm Ctrs.	Commcon Conn. Inc. 2202S-04G2
10	1	JP6	Jumper, 2pins 2mm Ctrs.	Commcon Conn. Inc. 2802S-02G2
11	6	XJP1-XJP6	Shunt, 2 Pins 2mm Ctrs.	Commcon Conn. Inc. CCIJ2MM-138G
12	1	REXT1	Trim. Pot., 50K	Panasonic EVM3YSX50B54
13	3	REXT2,R2,R4	Res., Chip 3.40K 0.1W 1%	AAC CR16-3401FM
14	1	R1	Res., Chip 5.11K 0.1W 1%	AAC CR16-5111FM
15	0	R3 (Opt)	Res., 1/4W	Philips
16	1	R6	Res., Chip 10 0.1W 1%	AAC CR16-10R0FM
17	14	TP1-TP14	Turret, Testpoint	Mill Max 2501-2
18	1	U1	I.C., 10th Order Lowpass Filter	Linear Tech. Corp. LTC1569CS8-6
19	1	U2	I.C., Op Amp	Linear Tech. Corp. LT1800CS5
20	4		SCREW, #4-40, 1/4"	ANY
21	4		STANDOFF, #4-40 1/4"	MICRO PLASTICS 14HTSP101
22	1		PRINTED CIRCUIT BOARD	DEMO CIRCUIT 626A