

THIS DRAWING IS UNPUBLISHED. RELEASED FOR PUBLICATION
 © COPYRIGHT BY TYCO ELECTRONICS CORPORATION. ALL RIGHTS RESERVED.

LOC		DIST		REVISIONS			
P	LTR	DESCRIPTION		DATE	DWN	APVD	
J	EC	0G3C 0221 05		02APR05	BSV	DLS	

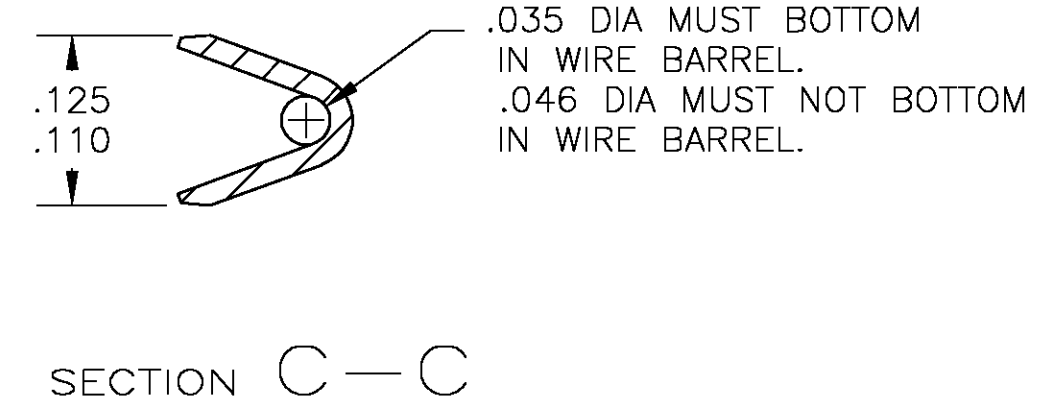
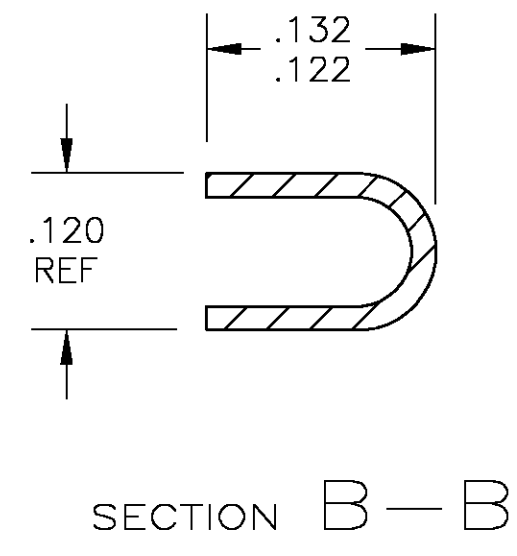
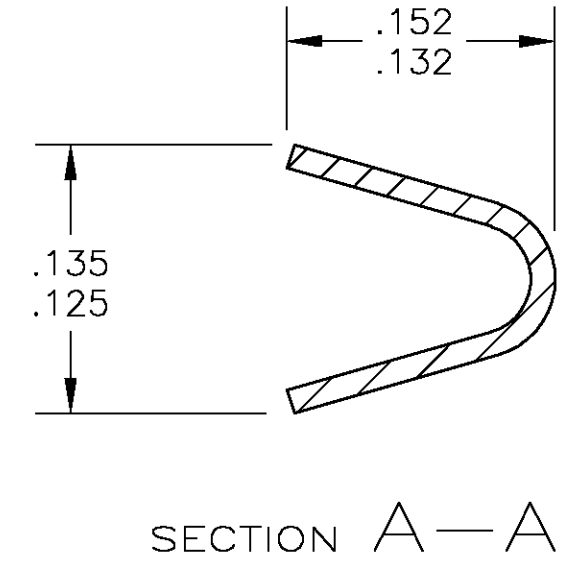
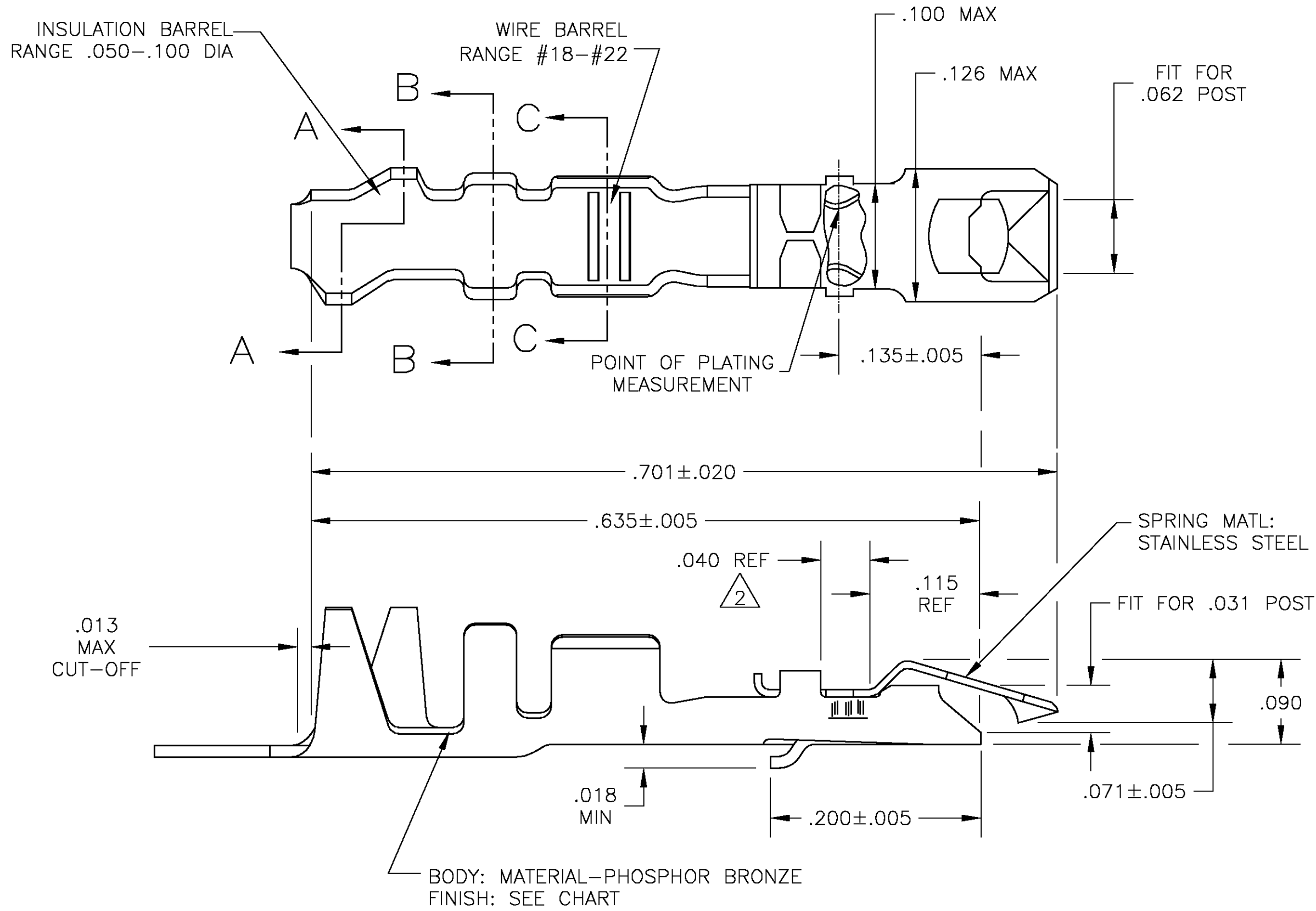

- 1 PLATED WITH .000100 TIN LEAD OVER .000050 NICKEL-ENTIRE CONTACT.
- 2 PLATED WITH .000015 GOLD IN CONTACT AREA, GOLD FLASH ON REMAINDER, OVER .000050 NICKEL.
- 3 .000100-.00200 BRIGHT TIN OVER .000050 NICKEL, ENTIRE CONTACT.

SUPERSEDED BY 5-87278-1

3	5-87278-1	5-87269-1
3	87278-3	87269-3
2	87278-2	87269-2
1	87278-1	87269-1
BODY FINISH	PART NO. (LOOSE PIECE)	PART NO. (STRIP)

THIS DRAWING IS A CONTROLLED DOCUMENT.		DWN 11-19-73	Tyco Electronics Corporation	
DIMENSIONS: INCHES		CHK 2-19-74	Harrisburg, Pa 17105-3608	
TOLERANCES UNLESS OTHERWISE SPECIFIED:		APVD 2-19-74	NAME	
0 PLC ± -		PRODUCT SPEC	CONTACT - LOCKING CLIP	
1 PLC ± -		APPLICATION SPEC	(FOR .031 X .062 POST) LOOSE PIECE	
2 PLC ± -		SIZE	CAGE CODE	DRAWING NO
3 PLC ± -		WEIGHT	A2 00779	C=87278
4 PLC ± -		CUSTOMER DRAWING	SCALE 10:1	SHEET 1 OF 1
ANGLES ± -		REV J		
FINISH SEE CHART				