

THIS DRAWING IS UNPUBLISHED. RELEASED FOR PUBLICATION  
 © COPYRIGHT BY TYCO ELECTRONICS CORPORATION. ALL RIGHTS RESERVED.

LOC	DIST	REVISIONS			
P	LTR	DESCRIPTION	DATE	DWN	APVD
AJ	16	B	REVISED PER ECO 07-018383	08AUG2007	DW MS

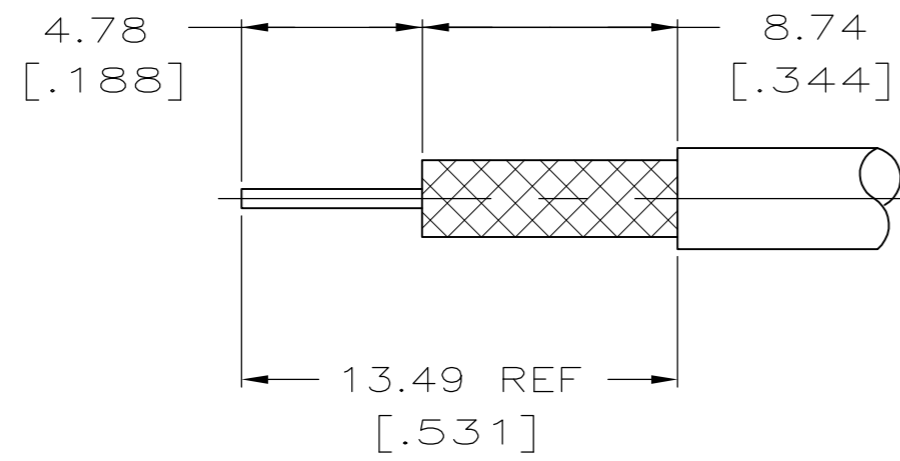
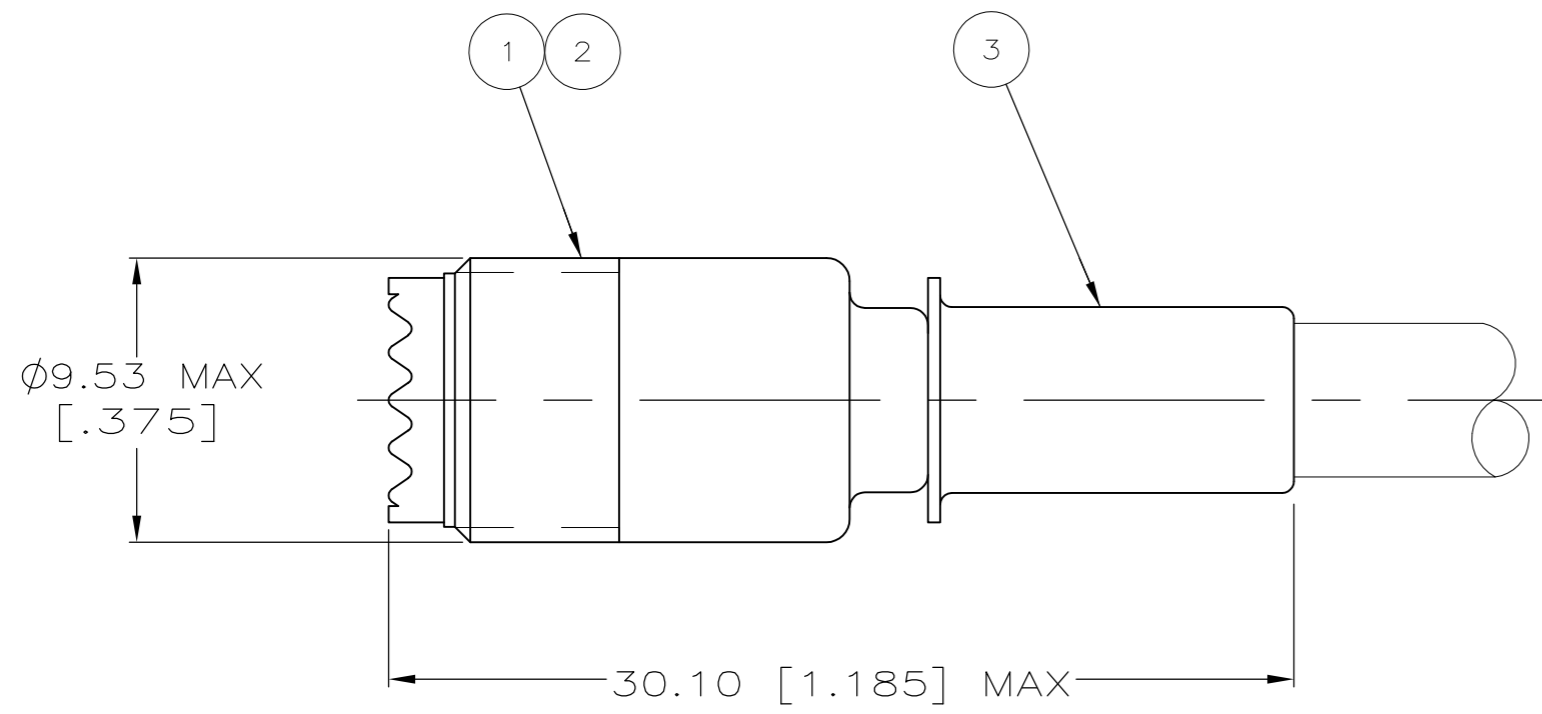

RECOMMENDED STRIP LENGTH

1. PARTS PACKAGED UNASSEMBLED

- ② CRIMP WITH TOOL: 69710-1 USING DIE 58158-1
- ③ CRIMP WITH TOOL: 220149-1 OR 58124-1
- ④ CRIMP WITH TOOL: AMP-O-ELECTRIC 220152-1 USING DIE 220162-1

②③④	RG-58/U,58A/U,58B/U & 58C/U	226599-2	226610-2	9-226850-0	5226602-1
CRIMP TOOL	FOR USE WITH:	③ FERRULE QTY=1	② CONTACT QTY=1	① JACK ASSY QTY=1	PART NO

THIS DRAWING IS A CONTROLLED DOCUMENT.		DWN J. ALCORTA - DOCK5 25APR2005	Tyco Electronics Corporation Harrisburg, PA 17105-3608																				
DIMENSIONS: mm [INCHES]		CHK J. HAVENER 25APR2005	NAME -																				
TOLERANCES UNLESS OTHERWISE SPECIFIED:		APVD G. MICHAEL 25APR2005	PRODUCT SPEC -																				
<table border="1"> <tr><td>0 PLC</td><td>±</td><td>-</td></tr> <tr><td>1 PLC</td><td>±</td><td>-</td></tr> <tr><td>2 PLC</td><td>±</td><td>0.41 [.016]</td></tr> <tr><td>3 PLC</td><td>±</td><td>-</td></tr> <tr><td>4 PLC</td><td>±</td><td>-</td></tr> <tr><td>ANGLES</td><td>±</td><td>-</td></tr> </table>		0 PLC	±	-	1 PLC	±	-	2 PLC	±	0.41 [.016]	3 PLC	±	-	4 PLC	±	-	ANGLES	±	-	APPLICATION SPEC -	SIZE A2	CAGE CODE 00779	DRAWING NO C=5226602
0 PLC	±	-																					
1 PLC	±	-																					
2 PLC	±	0.41 [.016]																					
3 PLC	±	-																					
4 PLC	±	-																					
ANGLES	±	-																					
MATERIAL -	FINISH -	WEIGHT -	RESTRICTED TO -																				
CUSTOMER DRAWING			SCALE 4:1	SHEET 1 of 1	REV B																		