

# ADSP-H5x1/H5x3

## 0.52" Single Digit PCB Based LED Display



### Datasheet

#### Description

This is 0.52" height single digit display. It utilizes AllnGaP Red, Orange, Yellow, Green and Deep Red chips. This device is halogenated.

All devices are categorized for luminous intensity. The orange, yellow and green devices are categorized for color. Use of similar device categories will yield a uniform display.

#### Features

- High reliability
- Excellent characters appearance
- Available in CA and CC
- RoHS Compliant
- Gray top surface with white diffused segments.

#### Ordering Information

Red	Green	Yellow	Orange	Deep Red	Description
ADSP-H5E1	ADSP-H5G1	ADSP-H5Y1	ADSP-H5L1	ADSP-H5A1	Common Anode, Right Hand Decimal
ADSP-H5E3	ADSP-H5G3	ADSP-H5Y3	ADSP-H5L3	ADSP-H5A3	Common Cathode, Right Hand Decimal

#### Package Dimensions

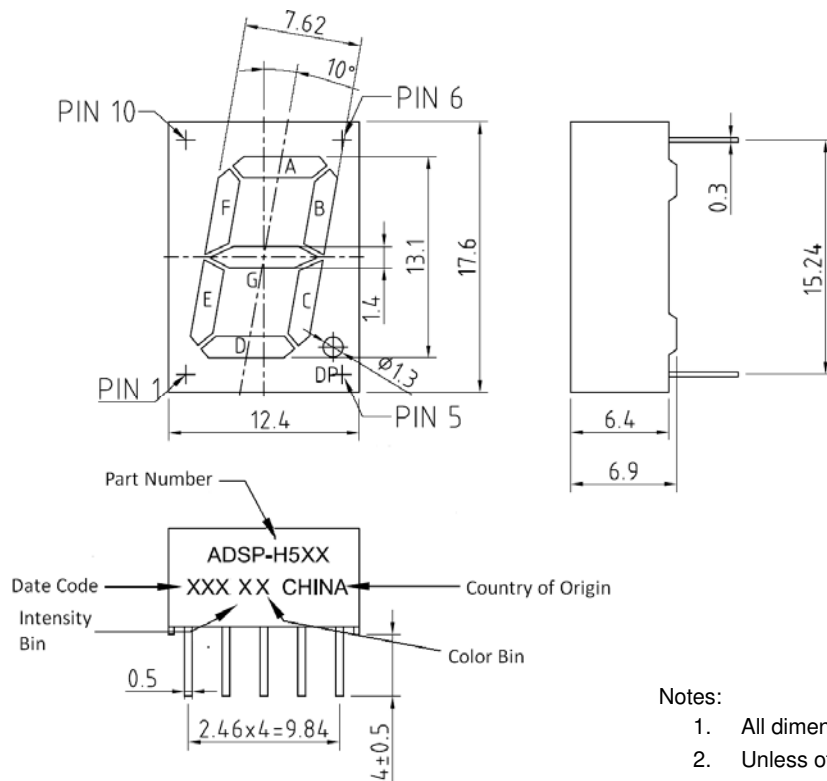

- Notes:
1. All dimensions are in millimeter.
  2. Unless otherwise stated, the tolerance is  $\pm 0.25$ mm.

For product information and a complete list of distributors, please go to our web site: [www.avagotech.com](http://www.avagotech.com)

## Circuit Diagram

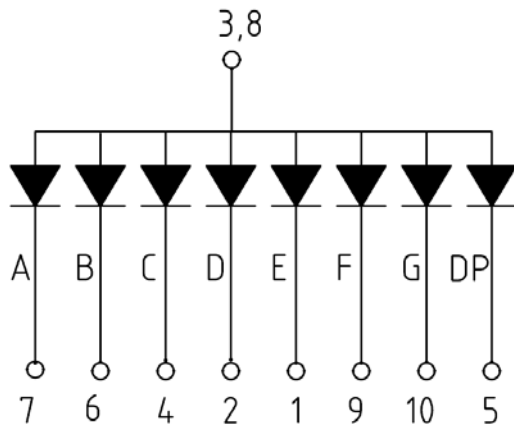

Common Anode

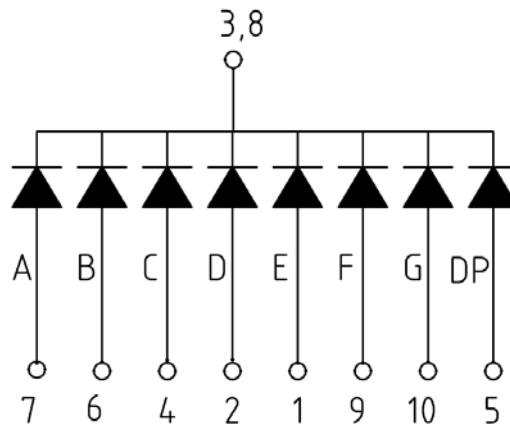

Common Cathode

## Absolute Maximum Ratings at $T_A = 25^\circ\text{C}$

Parameter	Symbol	Red/Yellow/ Orange/ Green/ Deep Red	Units
Power Dissipation per segment or Dot Point (DP)	$P_D$	52	mW
Continuous Forward Current per segment	$I_F$	20	mA
Peak Forward Current per segment (1/10 Duty Cycle, 0.1m sec pulse width)		100	mA
Derating Linearly from $25^\circ\text{C}$ per segment		0.21	mA/ $^\circ\text{C}$
Reverse Voltage per segment or DP	$V_R$	5	V
Operating Temperature	$T_O$	-40 to 85	$^\circ\text{C}$
Storage Temperature	$T_S$	-40 to 85	$^\circ\text{C}$
Wave solder Condition 1.6mm below body		260 $^\circ\text{C}$ peak for 3 secs max	

For product information and a complete list of distributors, please go to our web site: [www.avagotech.com](http://www.avagotech.com)

Avago, Avago Technologies, and the A logo are trademarks of Avago Technologies, Pte. in the United States and other countries.  
 Data subject to change. Copyright © 2005 Avago Technologies Pte. All rights reserved. Obsoletes Pub No.  
 Pub Number - Date (10/10/2012)

**Electrical / Optical Characteristic at  $T_A = 25^\circ\text{C}$** **Red**

Parameter	Symbol	Min	Typ	Max	Units	Test Conditions
Average Luminous Intensity (Digit Average)	$I_V$	–	40	–	mcd	$I_F = 10\text{mA}$
Peak Wavelength	$\lambda_p$	–	634	–	nm	$I_F = 20\text{mA}$
Dominant Wavelength	$\lambda_d$	–	625	–	nm	$I_F = 20\text{mA}$
Forward Voltage per segment / DP	$V_F$	–	2.0	2.6	V	$I_F = 20\text{mA}$
Reverse Current per segment / DP	$I_R$	–	–	100	$\mu\text{A}$	$V_R = 5\text{V}$
Luminous Intensity Matching Ratio (Segment to Segment)	$I_{V-M}$		2:1			$I_F = 10\text{mA}$

**Green**

Parameter	Symbol	Min	Typ	Max	Units	Test Conditions
Average Luminous Intensity (Digit Average)	$I_V$	–	15	–	mcd	$I_F = 10\text{mA}$
Peak Wavelength	$\lambda_p$	–	570	–	nm	$I_F = 20\text{mA}$
Dominant Wavelength	$\lambda_d$	–	571	–	nm	$I_F = 20\text{mA}$
Forward Voltage per segment / DP	$V_F$	–	2.0	2.6	V	$I_F = 20\text{mA}$
Reverse Current per segment / DP	$I_R$	–	–	100	$\mu\text{A}$	$V_R = 5\text{V}$
Luminous Intensity Matching Ratio (Segment to Segment)	$I_{V-M}$		2:1			$I_F = 10\text{mA}$

**Yellow**

Parameter	Symbol	Min	Typ	Max	Units	Test Conditions
Average Luminous Intensity (Digit Average)	$I_V$	–	33	–	mcd	$I_F = 10\text{mA}$
Peak Wavelength	$\lambda_p$	–	592	–	nm	$I_F = 20\text{mA}$
Dominant Wavelength	$\lambda_d$	–	587	–	nm	$I_F = 20\text{mA}$
Forward Voltage per segment / DP	$V_F$	–	2.0	2.6	V	$I_F = 20\text{mA}$
Reverse Current per segment / DP	$I_R$	–	–	100	$\mu\text{A}$	$V_R = 5\text{V}$
Luminous Intensity Matching Ratio (Segment to Segment)	$I_{V-M}$		2:1			$I_F = 10\text{mA}$

For product information and a complete list of distributors, please go to our web site: [www.avagotech.com](http://www.avagotech.com)

## Orange

Parameter	Symbol	Min	Typ	Max	Units	Test Conditions
Average Luminous Intensity (Digit Average)	$I_V$	–	40	–	mcd	$I_F = 10\text{mA}$
Peak Wavelength	$\lambda_P$	–	610	–	nm	$I_F = 20\text{mA}$
Dominant Wavelength	$\lambda_D$	–	605	–	nm	$I_F = 20\text{mA}$
Forward Voltage per segment / DP	$V_F$	–	2.0	2.6	V	$I_F = 20\text{mA}$
Reverse Current per segment / DP	$I_R$	–	–	100	$\mu\text{A}$	$V_R = 5\text{V}$
Luminous Intensity Matching Ratio (Segment to Segment)	$I_{V-M}$		2:1			$I_F = 10\text{mA}$

## Deep Red

Parameter	Symbol	Min	Typ	Max	Units	Test Conditions
Average Luminous Intensity (Digit Average)	$I_V$	–	35	–	mcd	$I_F = 10\text{mA}$
Peak Wavelength	$\lambda_P$	–	644	–	nm	$I_F = 20\text{mA}$
Dominant Wavelength	$\lambda_D$	–	635	–	nm	$I_F = 20\text{mA}$
Forward Voltage per segment / DP	$V_F$	–	2.0	2.6	V	$I_F = 20\text{mA}$
Reverse Current per segment / DP	$I_R$	–	–	100	$\mu\text{A}$	$V_R = 5\text{V}$
Luminous Intensity Matching Ratio (Segment to Segment)	$I_{V-M}$		2:1			$I_F = 10\text{mA}$

For product information and a complete list of distributors, please go to our web site: [www.avagotech.com](http://www.avagotech.com)

Avago, Avago Technologies, and the A logo are trademarks of Avago Technologies, Pte. in the United States and other countries.  
Data subject to change. Copyright © 2005 Avago Technologies Pte. All rights reserved. Obsoletes Pub No.  
Pub Number - Date (10/10/2012)

Red

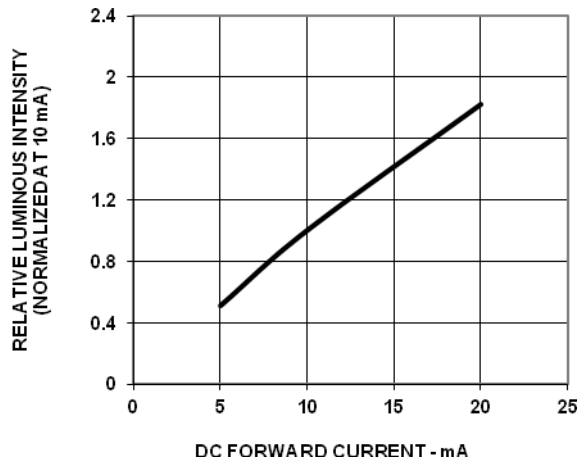

Fig 1: Relative Luminous Intensity Vs Forward Current

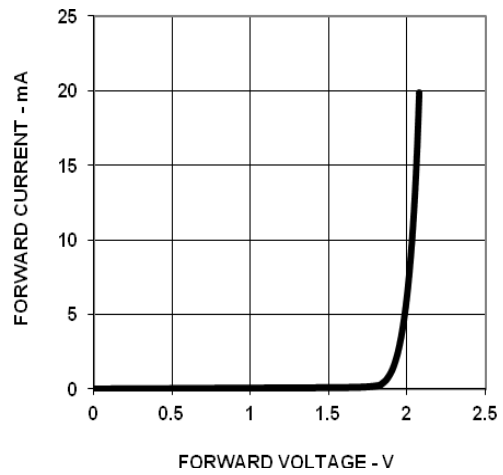

Fig 2: Forward Voltage Vs Current

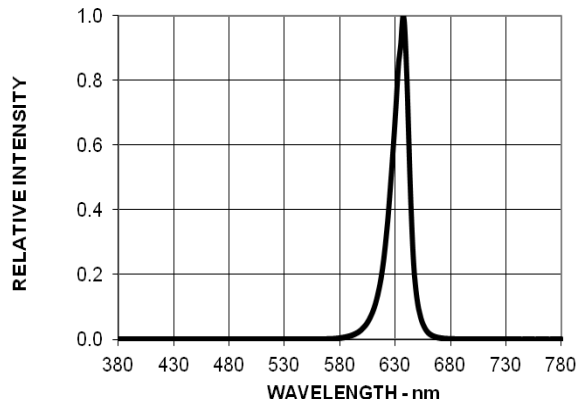

Fig 3: Relative Luminous Intensity Vs Wavelength

For product information and a complete list of distributors, please go to our web site: [www.avagotech.com](http://www.avagotech.com)

Avago, Avago Technologies, and the A logo are trademarks of Avago Technologies, Pte. in the United States and other countries. Data subject to change. Copyright © 2005 Avago Technologies Pte. All rights reserved. Obsoletes Pub No. Pub Number - Date (10/10/2012)

**AVAGO**  
TECHNOLOGIES

Green

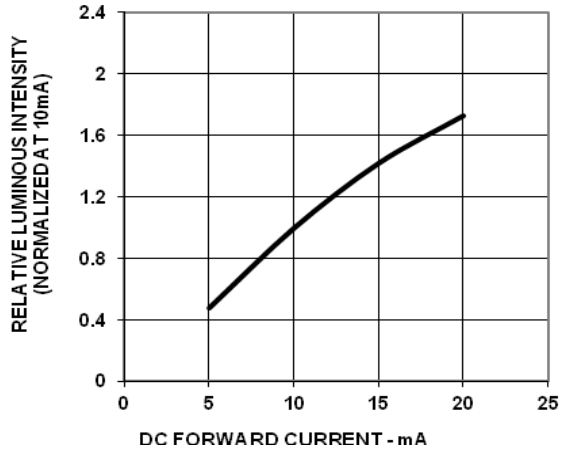

Fig 1: Relative Luminous Intensity Vs Forward Current

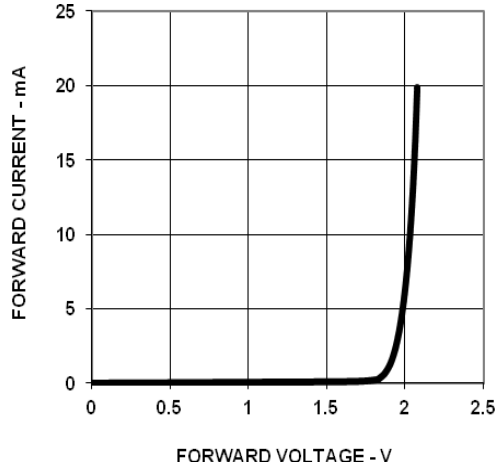

Fig 2: Forward Voltage Vs Current

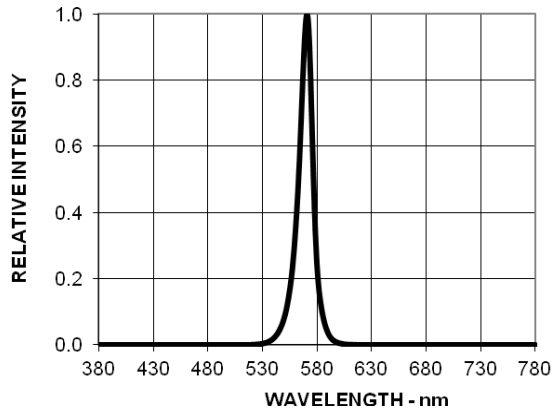

Fig 3: Relative Luminous Intensity Vs Wavelength

For product information and a complete list of distributors, please go to our web site: [www.avagotech.com](http://www.avagotech.com)

Avago, Avago Technologies, and the A logo are trademarks of Avago Technologies, Pte. in the United States and other countries. Data subject to change. Copyright © 2005 Avago Technologies Pte. All rights reserved. Obsoletes Pub No. Pub Number - Date (10/10/2012)



Yellow

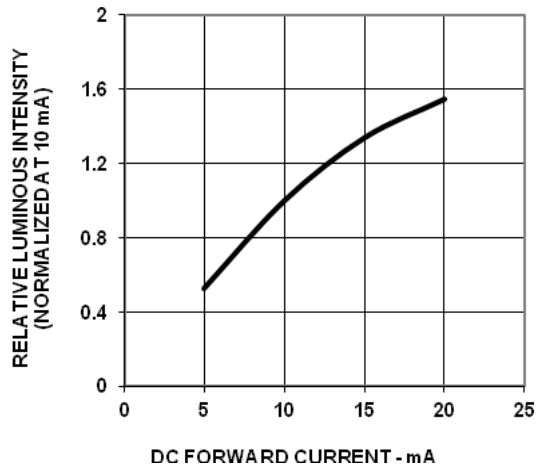

Fig 1: Relative Luminous Intensity Vs Forward Current

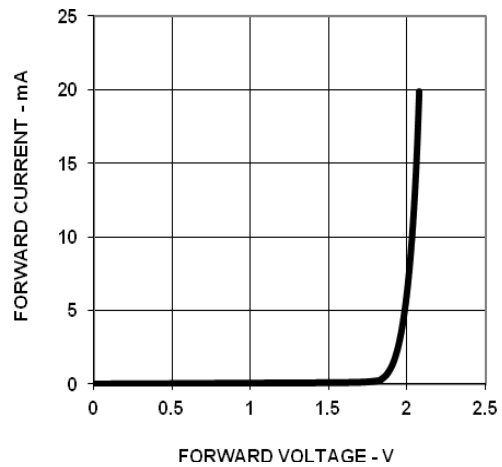

Fig 2: Forward Voltage Vs Current

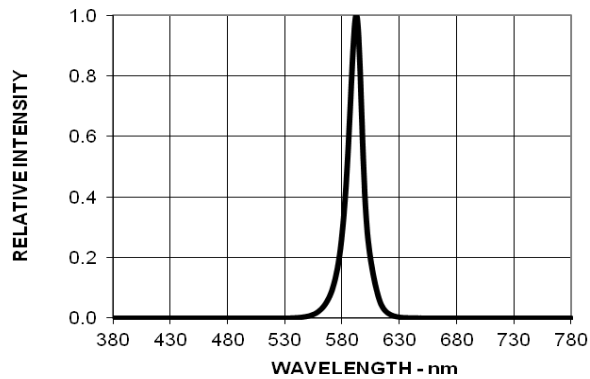

Fig 3: Relative Luminous Intensity Vs Wavelength

For product information and a complete list of distributors, please go to our web site: [www.avagotech.com](http://www.avagotech.com)

Avago, Avago Technologies, and the A logo are trademarks of Avago Technologies, Pte. in the United States and other countries. Data subject to change. Copyright © 2005 Avago Technologies Pte. All rights reserved. Obsoletes Pub No. Pub Number - Date (10/10/2012)

**AVAGO**  
TECHNOLOGIES

Orange

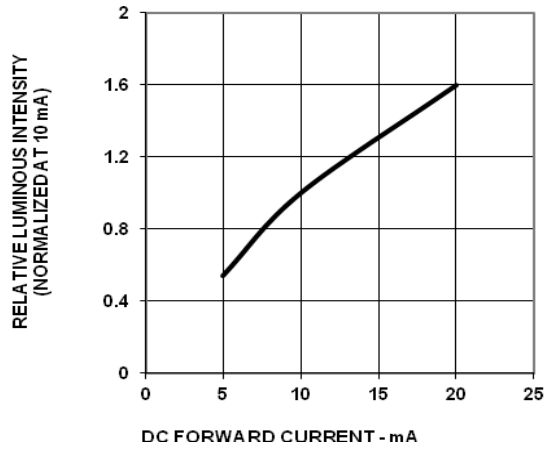

Fig 1: Relative Luminous Intensity Vs Forward Current

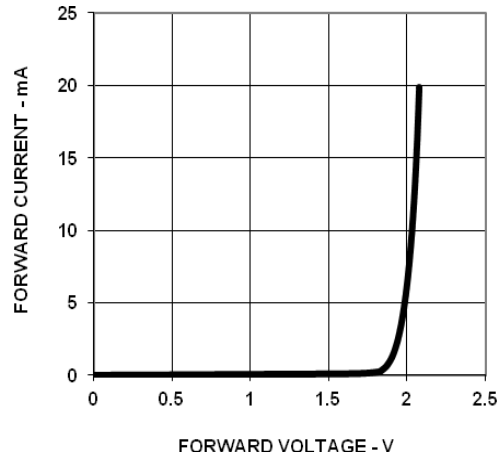

Fig 2: Forward Voltage Vs Current

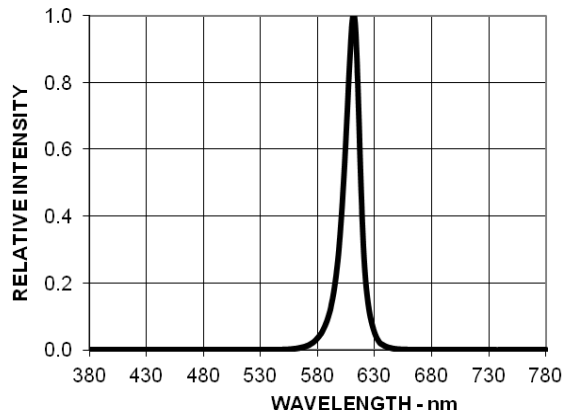

Fig 3: Relative Luminous Intensity Vs Wavelength

For product information and a complete list of distributors, please go to our web site: [www.avagotech.com](http://www.avagotech.com)

Avago, Avago Technologies, and the A logo are trademarks of Avago Technologies, Pte. in the United States and other countries. Data subject to change. Copyright © 2005 Avago Technologies Pte. All rights reserved. Obsoletes Pub No. Pub Number - Date (10/10/2012)

**AVAGO**  
TECHNOLOGIES



Deep Red

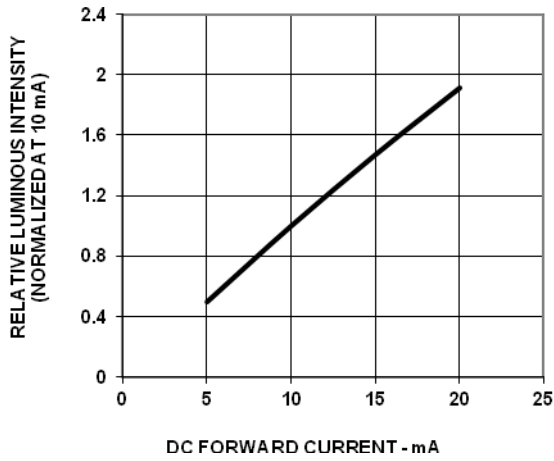

Fig 1: Relative Luminous Intensity Vs Forward Current

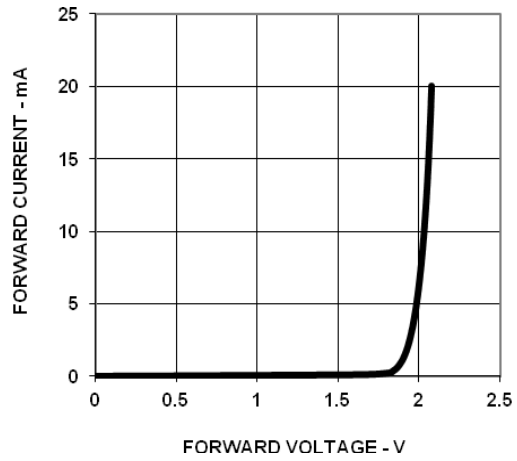

Fig 2: Forward Voltage Vs Current

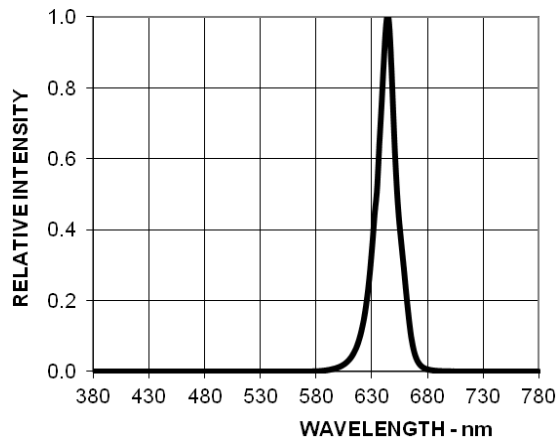

Fig3 : Relative Luminous Intensity Vs Wavelength

For product information and a complete list of distributors, please go to our web site: [www.avagotech.com](http://www.avagotech.com)

Avago, Avago Technologies, and the A logo are trademarks of Avago Technologies, Pte. in the United States and other countries. Data subject to change. Copyright © 2005 Avago Technologies Pte. All rights reserved. Obsoletes Pub No. Pub Number - Date (10/10/2012)

**AVAGO**  
TECHNOLOGIES

## Packing Tube Specifications:

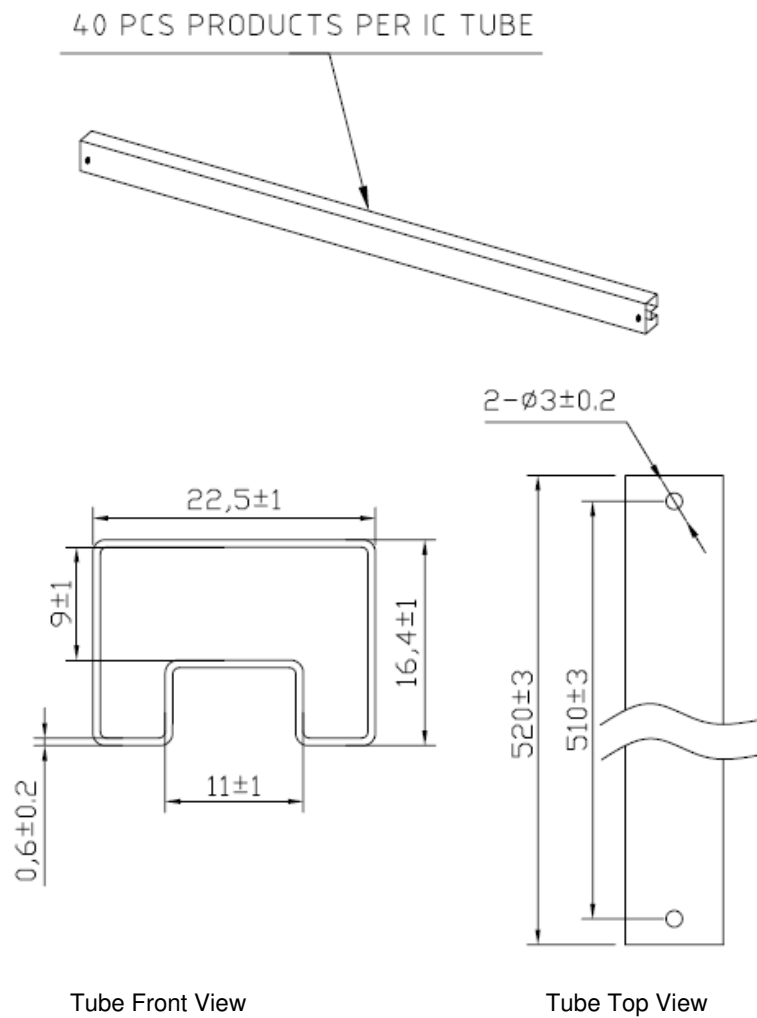

## Reference

For further information on soldering LEDs, please refer to Avago Technologies Application Note 1027.

For product information and a complete list of distributors, please go to our web site: [www.avagotech.com](http://www.avagotech.com)

Avago, Avago Technologies, and the A logo are trademarks of Avago Technologies, Pte. in the United States and other countries. Data subject to change. Copyright © 2005 Avago Technologies Pte. All rights reserved. Obsoletes Pub No. Pub Number - Date (10/10/2012)

**AVAGO**  
TECHNOLOGIES