

# ***ADS5240/5242 Evaluation Module***

## *User's Guide*

## IMPORTANT NOTICE

Texas Instruments Incorporated and its subsidiaries (TI) reserve the right to make corrections, modifications, enhancements, improvements, and other changes to its products and services at any time and to discontinue any product or service without notice. Customers should obtain the latest relevant information before placing orders and should verify that such information is current and complete. All products are sold subject to TI's terms and conditions of sale supplied at the time of order acknowledgment.

TI warrants performance of its hardware products to the specifications applicable at the time of sale in accordance with TI's standard warranty. Testing and other quality control techniques are used to the extent TI deems necessary to support this warranty. Except where mandated by government requirements, testing of all parameters of each product is not necessarily performed.

TI assumes no liability for applications assistance or customer product design. Customers are responsible for their products and applications using TI components. To minimize the risks associated with customer products and applications, customers should provide adequate design and operating safeguards.

TI does not warrant or represent that any license, either express or implied, is granted under any TI patent right, copyright, mask work right, or other TI intellectual property right relating to any combination, machine, or process in which TI products or services are used. Information published by TI regarding third-party products or services does not constitute a license from TI to use such products or services or a warranty or endorsement thereof. Use of such information may require a license from a third party under the patents or other intellectual property of the third party, or a license from TI under the patents or other intellectual property of TI.

Reproduction of information in TI data books or data sheets is permissible only if reproduction is without alteration and is accompanied by all associated warranties, conditions, limitations, and notices. Reproduction of this information with alteration is an unfair and deceptive business practice. TI is not responsible or liable for such altered documentation.

Resale of TI products or services with statements different from or beyond the parameters stated by TI for that product or service voids all express and any implied warranties for the associated TI product or service and is an unfair and deceptive business practice. TI is not responsible or liable for any such statements.

Following are URLs where you can obtain information on other Texas Instruments products and application solutions:

<b>Products</b>		<b>Applications</b>	
Amplifiers	<a href="http://amplifier.ti.com">amplifier.ti.com</a>	Audio	<a href="http://www.ti.com/audio">www.ti.com/audio</a>
Data Converters	<a href="http://dataconverter.ti.com">dataconverter.ti.com</a>	Automotive	<a href="http://www.ti.com/automotive">www.ti.com/automotive</a>
DSP	<a href="http://dsp.ti.com">dsp.ti.com</a>	Broadband	<a href="http://www.ti.com/broadband">www.ti.com/broadband</a>
Interface	<a href="http://interface.ti.com">interface.ti.com</a>	Digital Control	<a href="http://www.ti.com/digitalcontrol">www.ti.com/digitalcontrol</a>
Logic	<a href="http://logic.ti.com">logic.ti.com</a>	Military	<a href="http://www.ti.com/military">www.ti.com/military</a>
Power Mgmt	<a href="http://power.ti.com">power.ti.com</a>	Optical Networking	<a href="http://www.ti.com/opticalnetwork">www.ti.com/opticalnetwork</a>
Microcontrollers	<a href="http://microcontroller.ti.com">microcontroller.ti.com</a>	Security	<a href="http://www.ti.com/security">www.ti.com/security</a>
		Telephony	<a href="http://www.ti.com/telephony">www.ti.com/telephony</a>
		Video & Imaging	<a href="http://www.ti.com/video">www.ti.com/video</a>
		Wireless	<a href="http://www.ti.com/wireless">www.ti.com/wireless</a>

Mailing Address: Texas Instruments  
Post Office Box 655303 Dallas, Texas 75265

# Contents

---

---

---

<b>1</b>	<b>Features</b> .....	<b>5</b>
<b>2</b>	<b>Description</b> .....	<b>5</b>
<b>3</b>	<b>Power Supplies</b> .....	<b>5</b>
<b>4</b>	<b>Signals</b> .....	<b>5</b>
	4.1 External Reference .....	5
	4.2 Input Signals.....	5
	4.3 Output Signals.....	5
	4.4 Clock Signal .....	5
<b>5</b>	<b>Operation</b> .....	<b>6</b>
	5.1 Pushbuttons and Indicator LEDs .....	6
	5.2 Serial Data In .....	6
	5.3 Accessing the Internal Registers .....	6
	5.4 Installing the Software.....	7
	5.5 Using the Software .....	7
	5.6 Custom Pattern Generation .....	9
	5.7 LSB/MSB First Mode .....	9
<b>6</b>	<b>Bill of Materials</b> .....	<b>9</b>
<b>7</b>	<b>Schematic and PCB</b> .....	<b>11</b>

---

## List of Figures

1	Evaluation Board Overview.....	6
2	Initial Setup Screen .....	7
3	Register Access Program Screen .....	8
4	Register Access Program Screen – Custom Pattern Option.....	9
5	ADS5240/42EVM PCB – Top Layer .....	11
6	ADS5240/42EVM PCB – Ground Layer.....	12
7	ADS5240/42EVM PCB – Power Layer .....	12
8	ADS5240/42EVM PCB – Bottom Layer .....	13

## List of Tables

1	Component List.....	10
---	---------------------	----

---

---

## 1 Features

- Easy testing of the ADS5240/42 family of 12-bit data converters
- Single-ended, transformer coupled inputs.
- PC interface to control internal registers.

## 2 Description

The ADS5240/42EVM is designed to provide ease of use in evaluating the performance of the ADS5240/42 family of 12-bit analog to digital converters with LVDS outputs. When combined with the ADSDeSer-50EVM, a complete evaluation of the ADS5240/42 family can be performed.

## 3 Power Supplies

The ADS5240/42 EVM requires three supplies located on P3:

- AVDD – 3.3V DUT analog supply
- DVDD – 3.3V Digital supply for the microcontroller and RS232 level shifter
- LVDD – 1.8V to 3.3V LVDS output driver supply

By default AVDD, DVDD, and LVDD are tied together using a ferrite bead for ease of use. To separate the supplies, remove FB1, and FB2.

## 4 Signals

### 4.1 External Reference

By default, the ADS5240/42 EVM defaults to an internally generated reference. However, by asserting SW3, the ADS5240/42 will use the REFT and REFB supplied on P2 as its references.

### 4.2 Input Signals

The input signals are applied to SMA connectors J2, J4, J7 and J9. The input signals are transformer coupled to the inputs of the ADC.

### 4.3 Output Signals

The LVDS outputs from the ADC are sent to P6. P6 is used to connect the ADS5240/42EVM to the ADSDeSer-50EVM to provide a means to deserialize the data for external processing.

### 4.4 Clock Signal

Enter a clean, low jitter, 3Vpp clock on J1. The maximum clock frequency should be with the aid of the device data sheet. Either a sinusoidal or square-wave clock input can be accepted.

## 5 Operation

When power is applied to the board, the EVM performs an initialization sequence that sets the initial operation of the ADS5240/42. The Ref LED lights up to signify that the Int/Ext (bar over Ext) reference is set to internal. The RST LED is illuminated while a reset pulse is provided to the ADS5240/42 to reset the device for proper operation. The EVM is now operational and if connected to the ADSDESer-50EVM and reset pushbutton is pressed on the deserializer board, parallel data should be available on each channel output and a clock should be present on the clock output.

### 5.1 Pushbuttons and Indicator LEDs

The ADS5240/42EVM has three pushbuttons and four indicator LEDs. The pushbuttons and their corresponding LEDs are defined as follows:

- **SW1 - RST** - Reset of the ADS5240/42 device. (Resets only the ADS517x device)
- **SW2 – PD**– Power Down of the device. (LED on signifies complete device in power down)
- **SW3 – Ref**– Internal / External (bar over External) Reference Selection. (LED on signifies Internal)

The fourth LED, SDI, when illuminated signifies that data has been received from the PC through the serial link.

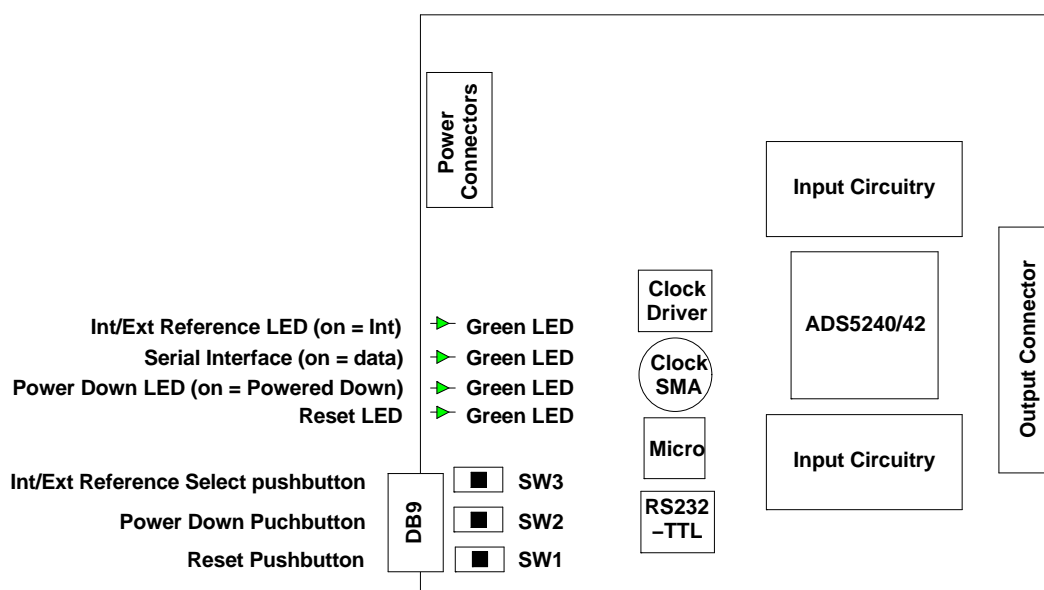

Figure 1. Evaluation Board Overview

### 5.2 Serial Data In

The Serial Data In (DB-9) connector is used to connect the EVM to a PC for accessing the internal registers of the ADS5240/42 device. This allows extended flexibility of the device beyond the simple power-up mode.

### 5.3 Accessing the Internal Registers

The ADS5240/42 family has internal registers that offer flexibility to the end user. In order to facilitate the ease of accessing these registers, the evaluation program is used. With the combination of a serial port on a PC, a serial link cable (provided), and the ADS5240/42EVM, the user has the ability to access the internal registers on the ADS5240/42 family of data converters.

## 5.4 Installing the Software

Installation of the software is straightforward. Insert the included CD or download the installation files from the Texas Instruments web site and double click on the Setup.exe file. This will install the program and all necessary files to the PC. Once the installation process is complete go to the *START > Programs > Texas Instruments > ADS524XEVM Software* icon to start the program.

**Note:** The installation files are also available for download from the TI web site at [www.ti.com](http://www.ti.com).

## 5.5 Using the Software

After clicking on the ADS5240/42EVM\_Software icon an initial startup screen will be displayed. The "Please select a Com port." Dialog box will appear on top of the above screen.



Figure 2. Inital Setup Screen

Select OK and then select the proper COM port from the drop-down list. The program lists all available COM ports to choose from. Once a COM port is selected the main program window will open.

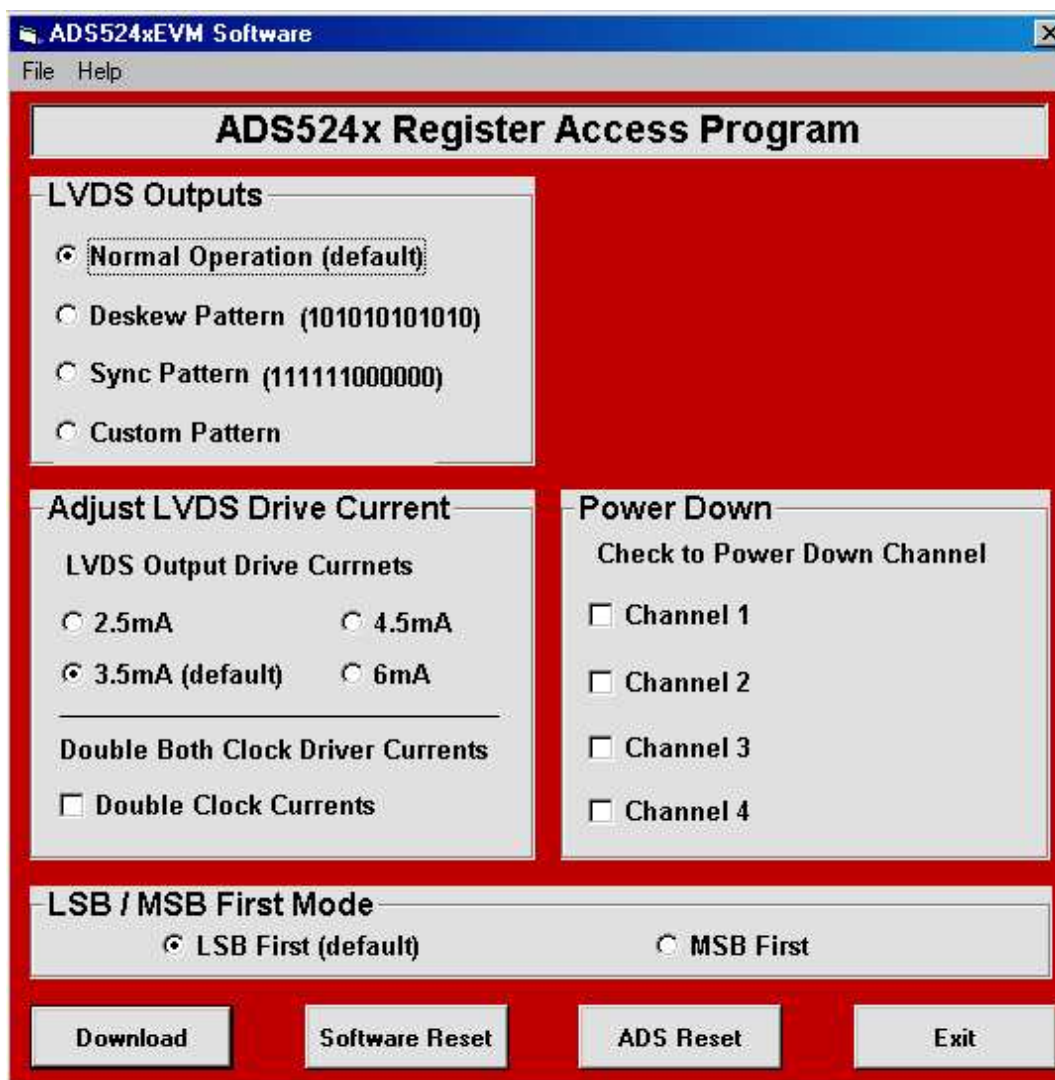

**Figure 3. Register Access Program Screen**

The main program window allows the user access to the registers of the ADS5240/42 family. With this program it is easy to change operating characteristics, send out test patterns, or power down any of the four channels of the ADS5240/42 converter. The software also contains the ability to reset the ADS remotely from the PC in addition to the pushbutton on the EVM board itself.

Once again, the operation of the program is straightforward. Make your selection and press the Download button. The proper codes are then sent from the PC to the ADS5240/42EVM board. A software reset is provided to reset all choices to their default values. To exit the program, selecting the Exit command button or go to File menu and select Exit.



## 5.6 Custom Pattern Generation

When using the custom pattern option all of the values are entered in a binary format (ie. 101011001111).

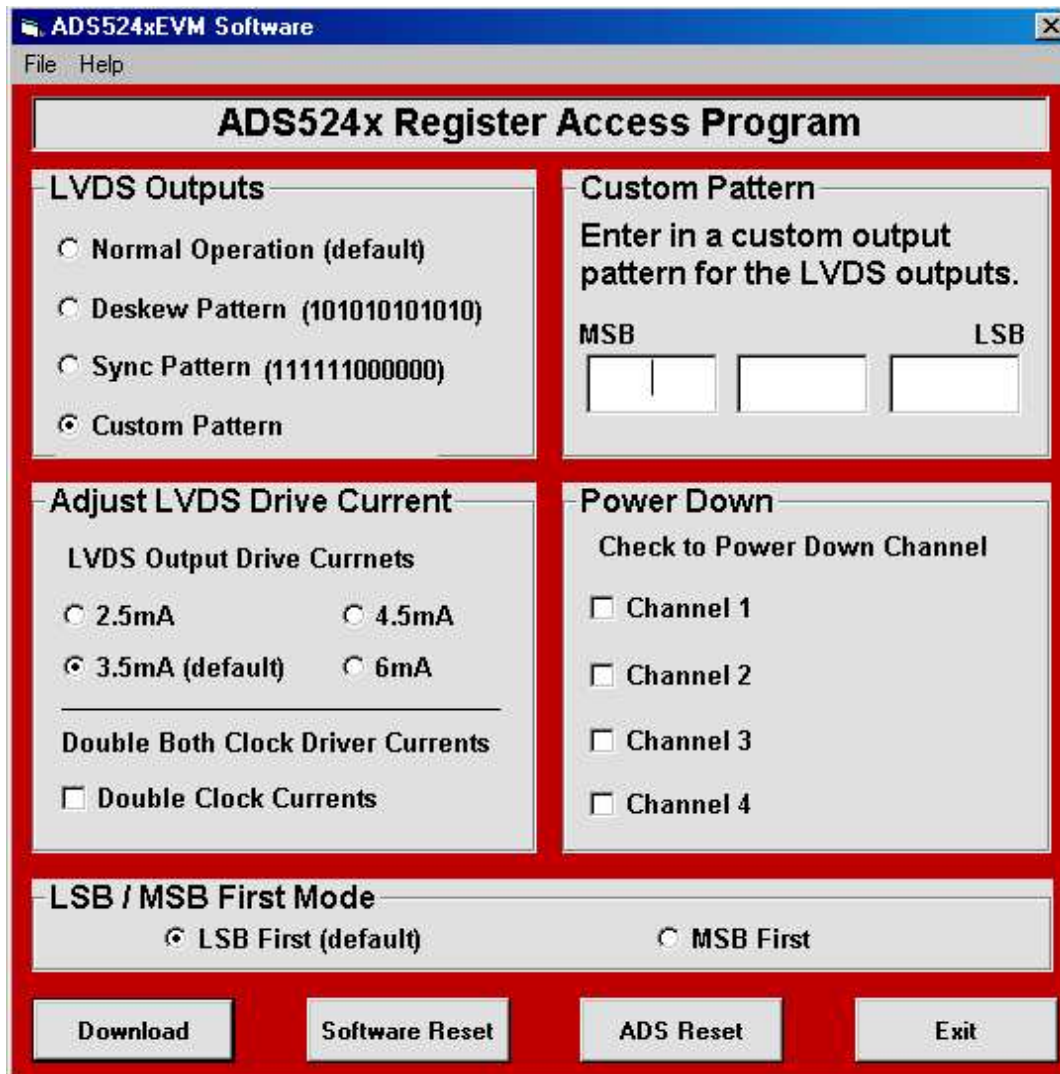

Figure 4. Register Access Program Screen – Custom Pattern Option

## 5.7 LSB/MSB First Mode

The default mode of data out of the ADS5240/42 device is LSB first. This mode can be changed by selecting the MSB First option in the software. This option increases the flexibility of the device.

---

**Note:** Changing to MSB First also reverses the internally generated test patterns and the custom pattern. This will show up on the Register Access screen as blue text.

---

## 6 Bill of Materials

**Table 1. Component List**

DESIGNATOR	QTY	PART NUMBER	VENDOR	PCB FOOTPRINT	NOTES
C1 C3 C4 C14 C15 C16 C18 C20 C22 C26 C27 C28 C31 C34 C36 C39 C40 C41 C42 C43 C44 C45 C46 C47 C49 C50 C51 C53 C54 C55 C57 C58 C59	29	ECJ0EB1A104K	Panasonic	0402	Do Not Install C45, C50, C54, C58
C2 C5	2	T491B225K016AS	KEMET	TANT_B	
C6 C9 C13	3	T491B475K016AS	KEMET	TANT_B	
C7 C8 C12	3	ECJ1VB1C104K	Panasonic	0603	
C17 C19 C21 C23 C24 C25 C29 C30 C32 C33	10	ECJ0EB1H102K	Panasonic	0402	
C37 C38 C61	3	ECJ0EB1C103K	Panasonic	0402	
C48 C52 C56 C60	4	ECJ0EC1H220J	Panasonic	0402	
CR1 CR2 CR3 CR4	4	SML-LX1206GC-TR	LUMEX	LED_1206	
FB1 FB2	2	RXC-ML32A680U	Panasonic	1206	
J1 J2 J3 J4 J5 J6 J7 J8 J9	5	142-0701-201	Johnson Components	SMA_THVT_320x320	Do Not Install J3, J5, J6, J8
P1	1	102203-3	Tyco/AMP	CON_THRT_1x6_100_M	
P2	1	AK550-3	ALTECH CORP	TERM_BLOCK_3_138	
P3	1	AK550-4	ALTECH CORP	TERM_BLOCK_4_138	
P5	1	DEKL-9SAT-F	CINCH	CON_THRT_DB_9_M_2	
P6	1	QTH-040-01-F-D-DP-A	SAMTEC		
R1 R4 R14 R15 R16 R19 R20 R22 R24 R25 R27 R29 R30 R32	6	CRCW0402000RF	Vishay/Dale	0402	Do Not Install R4, R15, R19, R20, R24, R25, R29, R30
R2	1	CRCW04025622F	Vishay/Dale	0402	
R5 R6	2	9C04021A2R00JGHF3	Yageo America	0402	
R7 R8 R9 R10	4	CRCW0402332RF	Vishay/Dale	0402	
R11 R12 R13	3	CRCW04024751F	Vishay/Dale	0402	
R17	1	ERJ-2RKF49R9X	Panasonic	0402	
R34	1	ERJ-2RKF54R9X	Panasonic	0402	
R35 R36 R37 R38 R39 R40 R41 R42 R43 R44 R45 R46 R47 R48 R49 R50	16	ERJ3EKF49R9V	Panasonic	0603	
R51 R52 R53	3	ERJ-2RKF4990X	Panasonic	0402	
SW1 SW2 SW3	3	EVQ-PJB04K	Panasonic	SW_THVT_SPST_2	
T1 T2 T3 T4	4	TRANS_SMVT_CD542_6	Minicircuits	ADT2-1T	
U1	1	SSOP_16_256x221_2_6	Maxim	MAX3221CDB	
U2	0	SSOP_20_289x212_2_6	CYPRESS	CY8C27243-24PVXI	See Note 2
U3	1	SSOP_8_124X114_26	ON SEMICONDUCTOR	MC100EPT21DT	
U4	0		Texas Instruments		See Note 1
NA	4		Richo Inc.	SRS4-8-01	1/2" Stand offs

## 7 Schematic and PCB

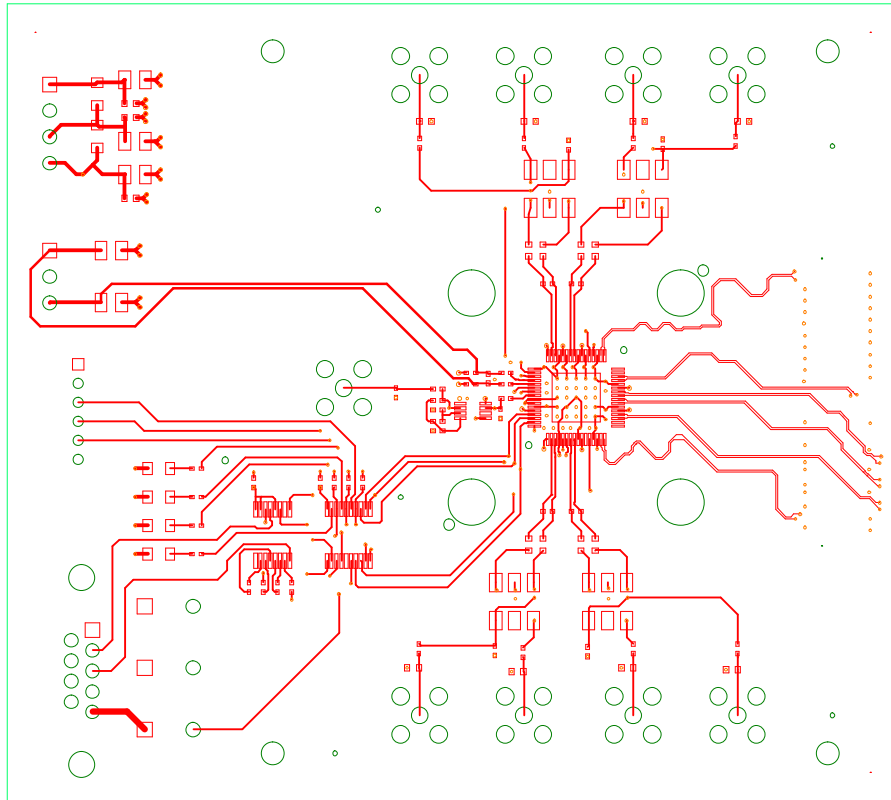

**Figure 5. ADS5240/42EVM PCB – Top Layer**

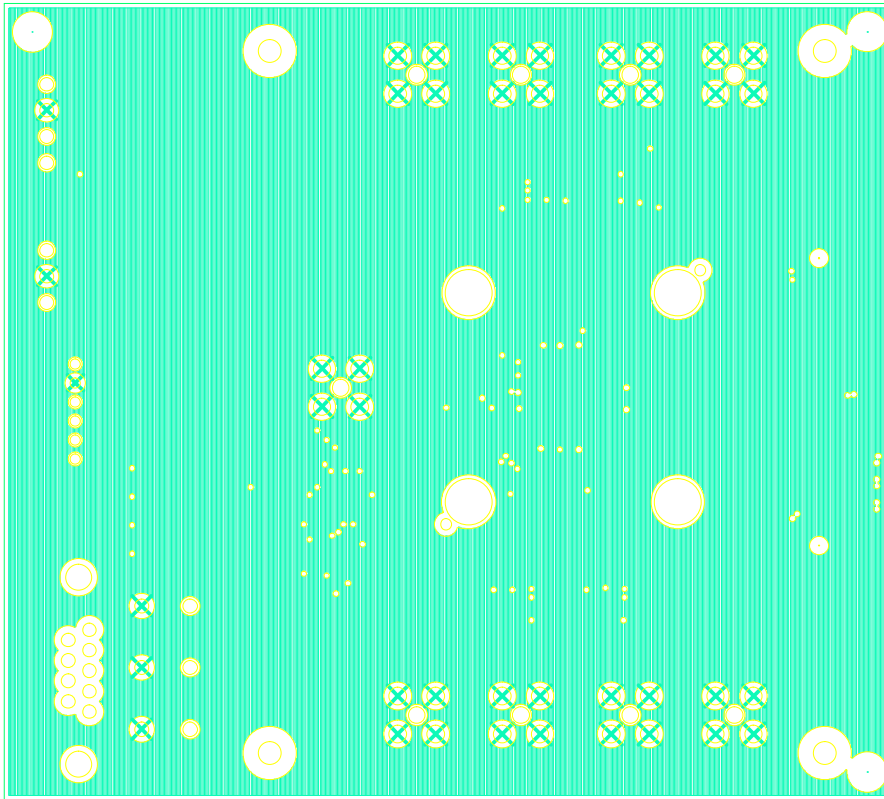

**Figure 6. ADS5240/42EVM PCB – Ground Layer**

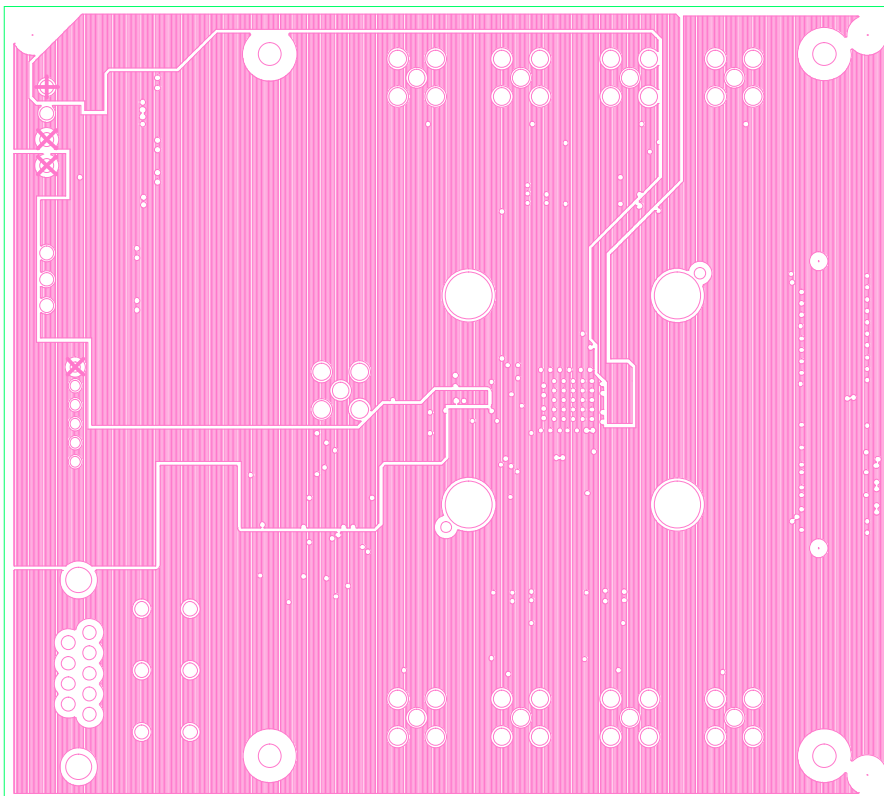

**Figure 7. ADS5240/42EVM PCB – Power Layer**

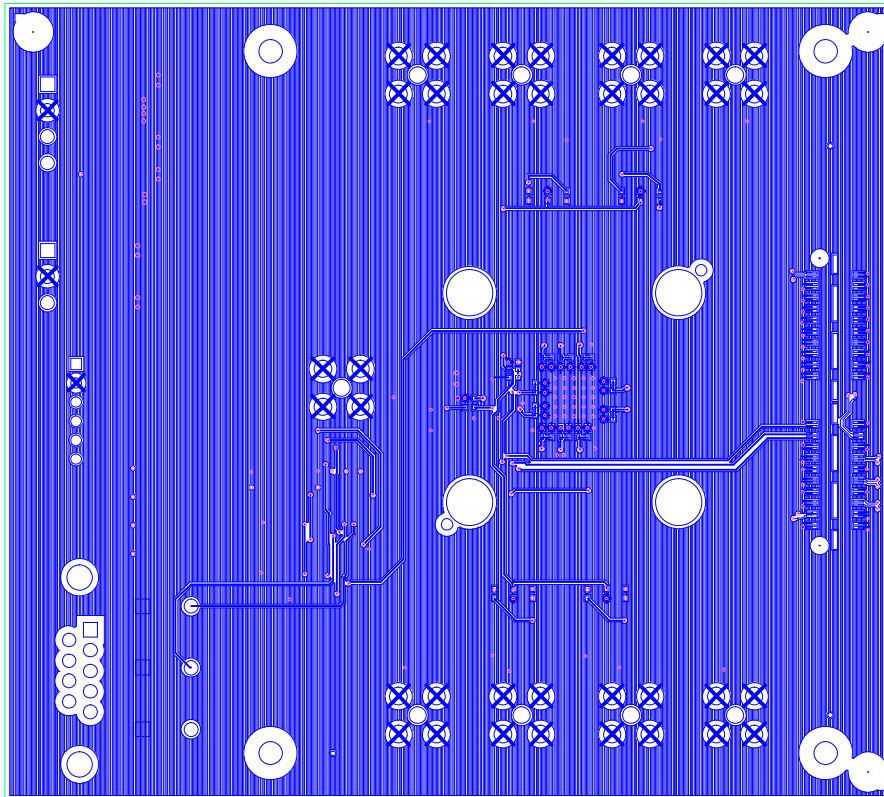
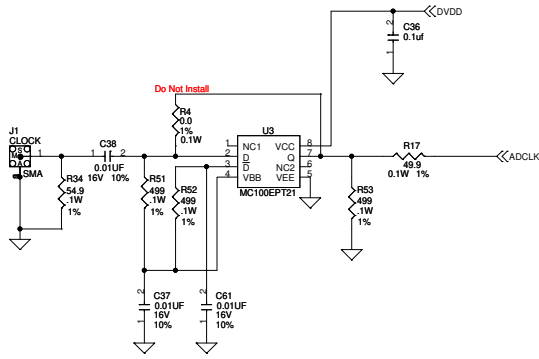
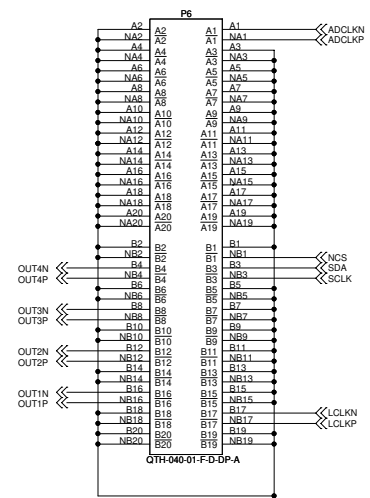
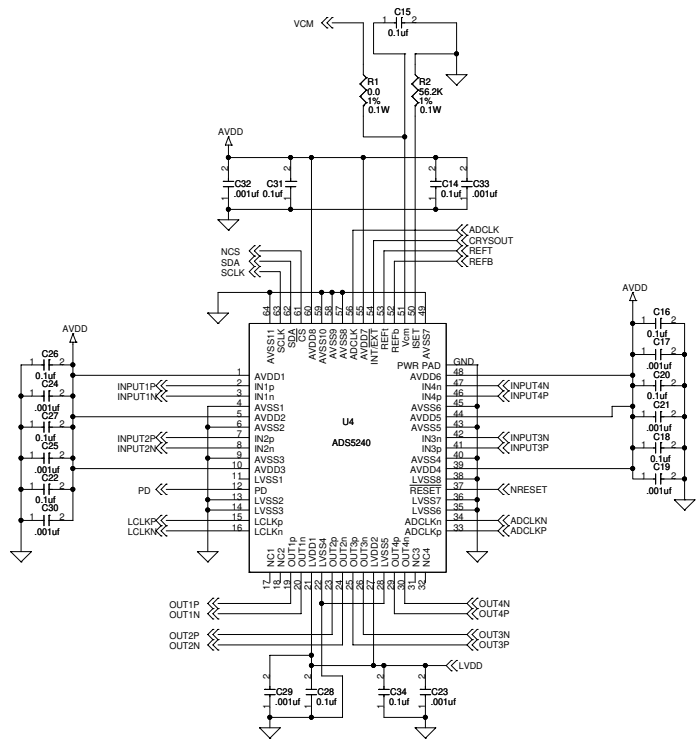
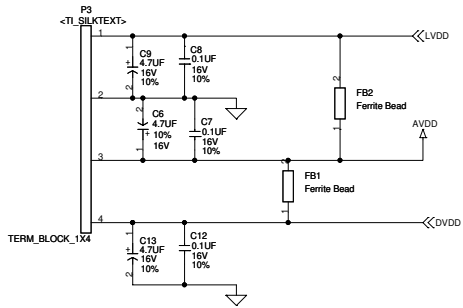
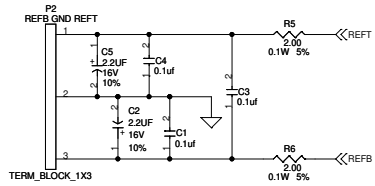

Figure 8. ADS5240/42EVM PCB – Bottom Layer



Texas Instruments 12500 TI Blvd Dallas, TX 75243		
Title ADSS24X EVM		
Size C	Document Number	Rev A
Date: Thursday, July 21, 2005	Sheet	1 of 2

