

# Crimping

---

<b>Crimping</b>	Introduction	D.2
	Overview contacts – tools	D.4
	Crimping tools for wire end ferrules	D.6
	Introduction – Crimping tools for other contacts	D.12
	Crimping tools for other contacts	D.14
	Pressing tools	D.24
	Crimping tools for connectors	D.26
	Crimping inserts	D.27
	Insertion tool for twisted-pair cables	D.29
	Crimp removal tools	D.30
	Tools for polymer optical fibre (POF)	D.31
	Cable tie tools	D.32

---

# Crimping

After stripping, appropriate contacts or wire end ferrules can be crimped to the cable end.

Crimping produces a reliable connection between conductor and contact, and has more or less completely replaced soldering.

Crimping describes the production of a uniform, nondetachable connection between conductor and connecting element.

This should be achieved exclusively by the use of a high-quality precision tool. The result is a safe, reliable connection in both electrical and mechanical terms.

Weidmüller offers a wide product range of mechanical crimping tools.

An integral ratchet mechanism with disengaging option guarantees optimum processing quality. Crimp connections produced with Weidmüller tools comply with international standards and specifications.

The DIN EN 60352-2 standard recommends that tools and contacts should come from the same manufacturer, since this is the only way to ensure consistently high quality. Otherwise, it is the user who is responsible for the quality. Weidmüller tools are designed to fit with Weidmüller contacts and thus are in full compliance with the DIN EN standard.

## Crimping of wire end ferrule: Optimum crimp of different cross-sections as an example

Examples for the visual inspection of a crimp connection with manual and automatic crimping tools by Weidmüller: The conductor insulation must be pushed into the plastic collar. The ferrule sleeve must be completely filled by the conductor. Depending on the cross-section, the conductor should protrude approx. 0 ... 0.5 mm from the ferrule sleeve.

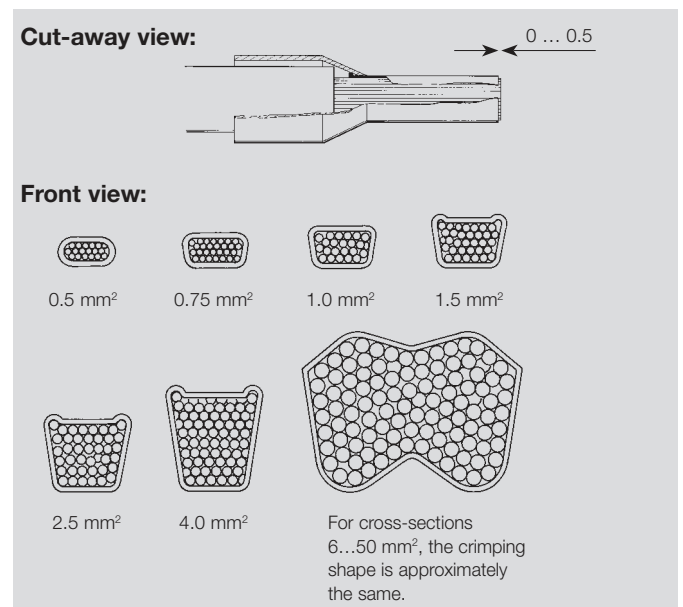

### Faulty crimping connections due to incorrect combination of cable and wire end ferrule

It is not possible for a tool to function reliably with every combination of conductor and crimping material.

It is possible that the standard requirements for the crimped product can't be achieved, although taken on their own, both conductor and crimping material comply with the corresponding standard. The individual production tolerances of conductor and crimping material do not allow every conductor to be combined with every contact.

The combination of conductors, crimping material and crimping tool must be coordinated: this procedure is all the more difficult given the large number of products on the market.

This means that the material must be defined and the crimping result tested, ensuring that the test, and later on the tool, satisfy the same conditions.

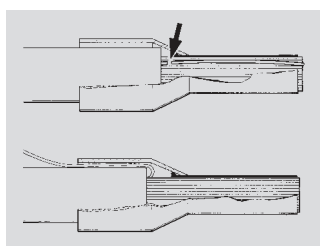

**Single conductor squeezed off**

**Single conductor pushed back**



### Faults which can occur during crimping:

- Cracks along the sides and die impressions
- Splitting of the ferrules
- Asymmetrical crimping shape
- Extreme burrs formed along the sides
- Ferrule not filled by the conductor
- Single conductors pushed back protruding from the collar
- Single conductors squeezed off
- Plastic collar damaged by the crimping jaw
- Conductor insulation not pushed into the plastic collar
- Ferrule bent longitudinally after crimping

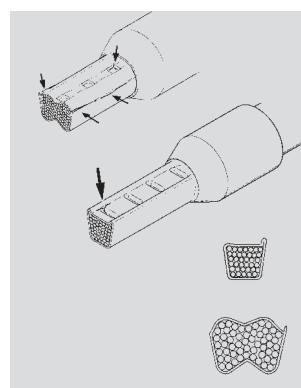

Formation of cracks at the sides.  
Sides split open

Formation of cracks at the  
impressions of the crimping jaw

Asymmetrical crimping shape  
Burr formation on one side

Asymmetrical crimping shape  
Burr formation on one side

#### Note:

The ferrule must not split open after it has been connected once in any Weidmüller terminal corresponding to the conductor cross-section (with a torque according to IEC 60947-1)

## Overview contacts – tools

Crimping

D

Crimp contact	Crimp type	Description	Conductor crossection in mm <sup>2</sup>	AWG	Crimping tool	Order No. tool	page	
Wire end ferrules		with plastic collar	0.5...2.5	20...14	Stripax Plus 2.5	9020000000	D.6	
		with / without plastic collar	0.14...6	26...10	PZ 6 roto	9014350000	D.9	
			0.25...1.5	24...16	PZ 1.5	9005990000	D.7	
			0.5...4	20...12	PZ 4	9012500000	D.8	
		with / without plastic collar	0.14...6	24...10	PZ 6 HEX	9013650000	D.7	
			0.25...6	24...10	PZ 6/5	9011460000	D.8	
		with / without plastic collar	0.5...6	20...10	PZ 3	0567300000	D.9	
				with / without plastic collar	6...16	10...6	PZ 16	9012600000
	25...50	3...1			PZ 50	9006450000	D.11	
	Twin wire end ferrules		Twin wire end ferrules	0.5...1	20...17	PZ 1.5	9005990000	D.7
				0.5...4	20...12	PZ 6 HEX	9013650000	D.7
				0.5...2.5	20...14	PZ 4	9012500000	D.8
0.5...4				20...12	PZ 6/5	9011460000	D.8	
0.5...4				20...12	PZ 3	0567300000	D.9	
0.5...4				20...12	PZ 6 roto	9014350000	D.9	
6...16				10...6	PZ ZH 16	9013600000	D.10	
Stamped contacts					Weidmüller DFF series	0.22...2.5	24...12	HTF DFF
	Weidmüller ZRV and MKF series	0.2...0.35 / 0.5...1	24...22 /		HTF ZRV	9014840000	D.23	
			20...17					
		Weidmüller FEKO ZRV series	0.2...2.5	24...12	HTF AFK 2.5	9201040000	D.23	
		Weidmüller RSV and DSTV-HD Systems	0.14...1.5	26...16	HTF RSV 16	9013560000	D.23	
	2.5	14...12	HTF RSV 12	9013550000	D.23			
Turned contacts		Turned HD and HE contacts	4...10	12...7	CTX CM 3.6	9018480000	D.18	
			0.14...4	26...12	CTX CM 1.6/2.5	9018490000	D.18	
		Turned HD, HE and HX contacts	0.14...6	26...10	CTIN CM 1.6/2.5	9205430000	D.18	
			1.5...10	16...7	CTIN CM 3.6	9205440000	D.18	

Crimp contact	Crimp type	Bezeichnung	Description in mm <sup>2</sup>	AWG	Crimping tool	Order No. tool	page	
coaxial connectors		coaxial connectors			HTG 58	9012000000	D.21	
					HTG 58/59	9012020000	D.21	
					HTG 59	9012010000	D.21	
					HTG 174	9012410000	D.21	
					HTX 138	9012400000	D.21	
		coaxial connectors			CTX 500	9006320000	D.22	
				CTX 501	9006370000	D.22		
				CTX 502	9006380000	D.22		
insulated / non-insulated connectors		insulated connectors	0.5...2.5	20...14	HTI 15	9014400000	D.16	
			0.5...6	20...10	CTI 6	9006120000	D.15	
			0.5...6	20...10	CTI 6 G	9202850000	D.15	
		non-insulated connectors	0.5...6	20...10	HTN 21	9014610000	D.16	
			0.5...6	20...10	HTN 21 with end stop	9014100000	D.16	
			10...25	7...3	CTN 25 D4	9006220000	D.17	
10...25			7...3	CTN 25 D5	9006230000	D.17		
modular plug connectors		WE-plug (4, 6 and 8-poles)	0.08...0.25	28...24	TT 864 RS WE	9008120000	D.25	
		WE-plug (4, 6 and 10-poles)	0.08...0.25	28...24	TT 1064 RS WE	9008190000	D.25	
		shielded WE-plug, system Hirose	0.08...0.25	28...24	TT 8 GH	9005640000	D.24	
			0.08...0.25	28...24	TT8 RS MP8	9202800000	D.24	
Other contacts and plugs		SUB-D contacts	0.08...0.5	28...20	HTF SUB-D	9013260000	D.22	
		flat blade connectors and receptacles	0.1...1 (connec. width 2.8)	27...17	HTF 28	9013090000	D.14	
			0.5...2.5 (connec. width 4.8)	20...14	HTF 48	9013080000	D.14	
			0.5...2.5 (connec. width 6.3)	20...14	HTF 63	9013400000	D.14	
			0.5...6 (connec. width 6.3)	20...10	CTF 63	9202860000	D.14	
		fibre optic connectors	Station 1 (hexagon crimp):			HTX LWL	9011360000	D.19
			3.15 / 6.0 H. → 3.9					
			Station 2 (round crimp):			HTX LWL	9011360000	D.19
			4.85 / 6.0 H. → 5.5					
	IP67 connector				IE-CT-SC-GOF	9205320000	D.20	
					IE-CT-LC-GOF	9205330000	D.20	
					IE-CT-SC-POF	9205340000	D.20	
					IE-CT-SC-GOF-P	9205350000	D.20	



## Crimping tools for wire end ferrules

### Crimping tools for wire end ferrules

#### Three functions:

- Cutting
- Stripping
- Crimping

- Wire-end ferrules with plastic collars, in compliance with DIN 46228-4
- Ratchet for precise crimping.
- Efficient operation: Change of tools not necessary, resulting in a significant time savings
- Automatic conveyance of wire-end ferrules
- Quick adjustment for differing cross-sections
- Easy handling of ferrule strips

**Only Weidmüller fifty-piece linked ferrule strips can be processed. The use of wire-end ferrules on reels can lead to damage.**

### stripax® plus 2.5

0,5...2,5 mm<sup>2</sup>



- For processing linked wire-end ferrules from Weidmüller 0.5...2.5 mm<sup>2</sup> (~AWG 20...14)



### Technical data

Description of contact	
Type of contact	
Crimping range	mm <sup>2</sup>
Crimping range 1 (with multiple crimping positions)	mm <sup>2</sup>
Crimping range 2 (with multiple crimping positions)	mm <sup>2</sup>
Crimping range 3 (with multiple crimping positions)	mm <sup>2</sup>
Crimping range 4 (with multiple crimping positions)	-
Crimping range 5 (with multiple crimping positions)	-
Tool data	
Length	mm
Weight	g
Note	

STRIPAX PLUS 2.5	
Strips of linked wire-end ferrules	
Crimping range	0.5...2.5
Crimping range 1 (with multiple crimping positions)	0.5...0.75
Crimping range 2 (with multiple crimping positions)	1...1.5
Crimping range 3 (with multiple crimping positions)	2.5
Crimping range 4 (with multiple crimping positions)	-
Crimping range 5 (with multiple crimping positions)	-
Tool data	
Length	210
Weight	260
Note	
Only strip-type products from Weidmüller can be processed. The use of wire-end ferrules on reels can lead to damage.	

### Ordering data

Version
Note

Type	Qty	Order No.
STRIPAX PLUS 2.5	1	9020000000
Spare cutting blade	1	9050340000

Additional accessories can be found in Chapter J.

**Crimping tools for wire end ferrules**

- For wire-end ferrules with and without plastic collars, according to DIN 46228 T.1 and T.4 (~ AWG 24...16)
- Ratchet for precise crimping.
- Release option in the event of incorrect operation

**PZ 1.5**

0.14...1.5 mm<sup>2</sup>



- Only one die for the whole cross-section range
- Crimp complies with Euro-Norm EN 60947-1
- Wire-end ferrule insertion from the front

**PZ 6 HEX**

0.14...6 mm<sup>2</sup>



- Only one die for the whole cross-section range
- Wire-end ferrule insertion from the side



**Technical data**

Description of contact	
Type of contact	
Crimping range	mm <sup>2</sup>
Crimping range 1 (with multiple crimping positions)	mm <sup>2</sup>
Crimping range 2 (with multiple crimping positions)	mm <sup>2</sup>
Crimping range 3 (with multiple crimping positions)	mm <sup>2</sup>
Crimping range 4 (with multiple crimping positions)	mm <sup>2</sup>
Crimping range 5 (with multiple crimping positions)	mm <sup>2</sup>
Tool data	
Length	mm
Weight	g
Note	

**Ordering data**

Version

Note

PZ 1.5		
Wire-end ferrules with/without plastic collars		
Crimping range		0.14...1.5
Crimping range 1 (with multiple crimping positions)		
Crimping range 2 (with multiple crimping positions)		
Crimping range 3 (with multiple crimping positions)		
Crimping range 4 (with multiple crimping positions)		
Crimping range 5 (with multiple crimping positions)		
Length	mm	170
Weight	g	170
Note		

Type	Qty	Order No.
PZ 1.5	1	9005990000

Additional accessories can be found in Chapter J.

PZ 6 HEX		
Wire-end ferrules with/without plastic collars		
Crimping range		0.14...6
Crimping range 1 (with multiple crimping positions)		
Crimping range 2 (with multiple crimping positions)		
Crimping range 3 (with multiple crimping positions)		
Crimping range 4 (with multiple crimping positions)		
Crimping range 5 (with multiple crimping positions)		
Length	mm	180
Weight	g	380
Note		

Type	Qty	Order No.
PZ 6 HEX	1	9013650000

Additional accessories can be found in Chapter J.

## Crimping tools for wire end ferrules

### Crimping tools for wire end ferrules

- For wire-end ferrules with and without plastic collars, according to DIN 46228 T.1 and T.4 (~ AWG 24...16)
- Ratchet for precise crimping.
- Release option in the event of incorrect operation

#### PZ 4

0.5...4 mm<sup>2</sup>



- Only one crimping station for the whole cross-section range
- Wire-end ferrule insertion from the side

#### PZ 6/5

0.25...6 mm<sup>2</sup>



- Crimp complies with Euro-Norm EN 60947-1
- Approval according to VG 95211 (military designation VG 95 236 T 14 B 002)
- Five crimping stations corresponding to the conductor cross-sections
- Wire-end ferrule insertion from the side



### Technical data

Description of contact	
Type of contact	
Crimping range	mm <sup>2</sup>
Crimping range 1 (with multiple crimping positions)	mm <sup>2</sup>
Crimping range 2 (with multiple crimping positions)	mm <sup>2</sup>
Crimping range 3 (with multiple crimping positions)	mm <sup>2</sup>
Crimping range 4 (with multiple crimping positions)	mm <sup>2</sup>
Crimping range 5 (with multiple crimping positions)	mm <sup>2</sup>
Tool data	
Length	mm
Weight	g
Note	

### Ordering data

Version
Note

PZ 4		
Wire-end ferrules with/without plastic collars		
Crimping range		0.5...4
Crimping range 1 (with multiple crimping positions)		
Crimping range 2 (with multiple crimping positions)		
Crimping range 3 (with multiple crimping positions)		
Crimping range 4 (with multiple crimping positions)		
Crimping range 5 (with multiple crimping positions)		
Tool data		
Length	mm	200
Weight	g	448
Note		

Type	Qty	Order No.
PZ 4	1	9012500000

Additional accessories can be found in Chapter J.

PZ 6/5		
Wire-end ferrules with/without plastic collars		
Crimping range		0.25...6
Crimping range 1 (with multiple crimping positions)		0.25...0.5
Crimping range 2 (with multiple crimping positions)		0.75...1.5
Crimping range 3 (with multiple crimping positions)		2.5
Crimping range 4 (with multiple crimping positions)		4
Crimping range 5 (with multiple crimping positions)		6
Tool data		
Length	mm	200
Weight	g	423
Note		

Type	Qty	Order No.
PZ 6/5	1	9011460000

Additional accessories can be found in Chapter J.



**Crimping tools for wire end ferrules**

- For wire-end ferrules with and without plastic collars, according to DIN 46228 T.1 and T.4 (~ AWG 24...16)
- Ratchet for precise crimping.
- Release option in the event of incorrect operation

**PZ 3**

0.5...6 mm<sup>2</sup>



- Only one die for the whole cross-section range
- Wire-end ferrule insertion from the front

**PZ 6 roto**

0.14...6 mm<sup>2</sup>



- Only one die for the whole cross-section range
- Rotating die enables wire-end ferrule insertion from the front or side



**Technical data**

Description of contact	
Type of contact	
Crimping range	mm <sup>2</sup>
Crimping range 1 (with multiple crimping positions)	mm <sup>2</sup>
Crimping range 2 (with multiple crimping positions)	mm <sup>2</sup>
Crimping range 3 (with multiple crimping positions)	mm <sup>2</sup>
Crimping range 4 (with multiple crimping positions)	mm <sup>2</sup>
Crimping range 5 (with multiple crimping positions)	mm <sup>2</sup>
Tool data	
Length	mm
Weight	g
Note	

**Ordering data**

Version
Note

PZ 3		
Wire-end ferrules with/without plastic collars		
Crimping range	mm <sup>2</sup>	0.5...6
Crimping range 1 (with multiple crimping positions)	mm <sup>2</sup>	
Crimping range 2 (with multiple crimping positions)	mm <sup>2</sup>	
Crimping range 3 (with multiple crimping positions)	mm <sup>2</sup>	
Crimping range 4 (with multiple crimping positions)	mm <sup>2</sup>	
Crimping range 5 (with multiple crimping positions)	mm <sup>2</sup>	
Tool data		
Length	mm	200
Weight	g	426
Note		
Additional accessories can be found in Chapter J.		

Type	Qty	Order No.
PZ 3	1	0567300000

PZ 6 Roto		
Wire-end ferrules with/without plastic collars		
Crimping range	mm <sup>2</sup>	0.14...6
Crimping range 1 (with multiple crimping positions)	mm <sup>2</sup>	
Crimping range 2 (with multiple crimping positions)	mm <sup>2</sup>	
Crimping range 3 (with multiple crimping positions)	mm <sup>2</sup>	
Crimping range 4 (with multiple crimping positions)	mm <sup>2</sup>	
Crimping range 5 (with multiple crimping positions)	mm <sup>2</sup>	
Tool data		
Length	mm	200
Weight	g	428
Note		
Additional accessories can be found in Chapter J.		

Type	Qty	Order No.
PZ 6 Roto	1	9014350000

Additional accessories can be found in Chapter J.

## Crimping tools for wire end ferrules

### Crimping tools for wire end ferrules

- For wire-end ferrules with and without plastic collars, according to DIN 46228 T.1 and T.4 (~ AWG 24...16)
- Ratchet for precise crimping.
- Release option in the event of incorrect operation

#### PZ 16

6...16 mm<sup>2</sup>



- Crimp complies with Euro-Norm EN 60947-1
- Approval according to VG 95211 (military designation VG 95 236 T 14 B 002)
- Three crimping stations corresponding to the conductor cross-sections
- Wire-end ferrule insertion from the side

#### PZ ZH 16

Twin wire-end ferrules from 6...16 mm<sup>2</sup>



- Three crimping stations corresponding to the conductor cross-sections
- Wire-end ferrule insertion from the side



### Technical data

Description of contact	
Type of contact	
Crimping range	mm <sup>2</sup>
Crimping range 1 (with multiple crimping positions)	mm <sup>2</sup>
Crimping range 2 (with multiple crimping positions)	mm <sup>2</sup>
Crimping range 3 (with multiple crimping positions)	mm <sup>2</sup>
Crimping range 4 (with multiple crimping positions)	mm <sup>2</sup>
Crimping range 5 (with multiple crimping positions)	mm <sup>2</sup>
Tool data	
Length	mm
Weight	g
Note	

### Ordering data

Version
Note

PZ 16		
Wire-end ferrules with/without plastic collars		
Crimping range	mm <sup>2</sup>	
	6...16	
Crimping range 1 (with multiple crimping positions)	mm <sup>2</sup>	6
Crimping range 2 (with multiple crimping positions)	mm <sup>2</sup>	10
Crimping range 3 (with multiple crimping positions)	mm <sup>2</sup>	16
Crimping range 4 (with multiple crimping positions)	mm <sup>2</sup>	
Crimping range 5 (with multiple crimping positions)	mm <sup>2</sup>	
Tool data		
Length	mm	200
Weight	g	418
Note		

Type	Qty	Order No.
PZ 16	1	9012600000

Additional accessories can be found in Chapter J.

PZ ZH 16		
Twin wire-end ferrules		
Crimping range	mm <sup>2</sup>	
	6...16	
Crimping range 1 (with multiple crimping positions)	mm <sup>2</sup>	6
Crimping range 2 (with multiple crimping positions)	mm <sup>2</sup>	10
Crimping range 3 (with multiple crimping positions)	mm <sup>2</sup>	16
Crimping range 4 (with multiple crimping positions)	mm <sup>2</sup>	
Crimping range 5 (with multiple crimping positions)	mm <sup>2</sup>	
Tool data		
Length	mm	250
Weight	g	730
Note		

Type	Qty	Order No.
PZ ZH 16	1	9013600000

Additional accessories can be found in Chapter J.

## Crimping tools for wire end ferrules

- For wire-end ferrules with and without plastic collars, according to DIN 46228 T.1 and T.4 (~ AWG 24...16)
- Ratchet for precise crimping.
- Release option in the event of incorrect operation

### PZ 50

25...50 mm<sup>2</sup>



- Crimp complies with Euro-Norm EN 60947-1
- Approval according to VG 95211 (military designation VG 95 236 T 14 B 002)
- Three crimping stations corresponding to the conductor cross-sections
- Wire-end ferrule insertion from the side



## Technical data

Description of contact	
Type of contact	
Crimping range	mm <sup>2</sup>
Crimping range 1 (with multiple crimping positions)	mm <sup>2</sup>
Crimping range 2 (with multiple crimping positions)	mm <sup>2</sup>
Crimping range 3 (with multiple crimping positions)	mm <sup>2</sup>
Crimping range 4 (with multiple crimping positions)	-
Crimping range 5 (with multiple crimping positions)	-
Tool data	
Length	mm
Weight	g
Note	

PZ 50	
Wire-end ferrules with/without plastic collars	
Crimping range	25...50
Crimping range 1	25
Crimping range 2	35
Crimping range 3	50
Crimping range 4	-
Crimping range 5	-
Length	250
Weight	730
Note	

## Ordering data

Version
Note

Type	Qty	Order No.
PZ 50	1	9006450000

Additional accessories can be found in Chapter J.

## Crimping tool for custom contacts

The crimping technique is one of the most reliable and most versatile connection methods. Extreme quality demands for a variety of different connections require that you use a wide variety of specialized crimping tools which are designed for specific contacts.

Weidmüller offers the right crimping tool for a wide variety of contacts. Regardless if you are using turned contacts, cable-lug connectors, insulated connectors or coaxial connectors.









## Crimping tools for other contacts

### Crimping tools for other contacts

- Ratchet for precise crimping.
- Release option in the event of incorrect operation
- With locator for exact positioning of the contacts.
- Contact and insulation are crimped in one step

#### HTF 28 / HTF 48 / HTF 63

0.1...2.5 mm<sup>2</sup>



For cable-lug sleeves and cable-lug (flat blade) connectors with pre-rolled crimping claw

#### HTF 28

Connector width: 2.8 mm, from 0.1...1.0 mm<sup>2</sup>

#### HTF 48

Connector width: 4.8 mm, from 0.5...2.5 mm<sup>2</sup>

#### HTF 63

Connector width: 6.3 mm, from 0.5...2.5 mm<sup>2</sup>



### Technical data

Description of contact	
Type of contact	
Crimping range	mm <sup>2</sup>
Crimping range 1 (with multiple crimping positions)	mm <sup>2</sup>
Crimping range 2 (with multiple crimping positions)	mm <sup>2</sup>
Crimping range 3 (with multiple crimping positions)	mm <sup>2</sup>
Plug width	mm
Tool data	
Length	mm
Weight	g
Note	

HTF 28	HTF 48	HTF 63
F-plug / -sleeve	F-plug / -sleeve	F-plug / -sleeve
0.1...1	0.5...2.5	0.5...2.5
0.1...0.25	0.5...1	0.5...1
0.25...0.5	1.5...2.5	1.5...2.5
0.6...1		
2.8	4.8	6.3
200	200	200
438	438	438
Note		

### Ordering data

Version
Note

Type	Qty	Order No.
HTF 28	1	9013090000
HTF 48	1	9013080000
HTF 63	1	9013400000
Note		

#### CTF 63

0.5...6 mm<sup>2</sup>



For cable-lug sleeves and cable-lug (flat blade) connectors with pre-rolled crimping claw

#### CTF 63

Connector width: 6.3 mm, from 0.5...6 mm<sup>2</sup>



CTF 63	
F-plug / -sleeve	
0.5...6	
0.5...1	
1.5...2.5	
2.6...6	
6.3	
250	
730	
Note	

Type	Qty	Order No.
CTF 63	1	9202860000
Note		

### Crimping tools for other contacts

- Ratchet for precise crimping.
- Release option in the event of incorrect operation
- With stop for exact positioning of the contacts.

#### CTI 6 G

0,5...6 mm<sup>2</sup>



For PVC, PC, and polyamide insulated connectors  
**0.5...6 mm<sup>2</sup>**  
 (~AWG 20 ... AWG 10)

- Parallel-crimp profile, for crimping contact and insulation in one step



#### CTI 6

0,5...6 mm<sup>2</sup>



For PVC, PC, and polyamide insulated connectors  
**0.5...6 mm<sup>2</sup>**  
 (~AWG 20 ... AWG 10)

- Double-crimp profile, for crimping contact and insulation in one step



### Technical data

Description of contact	
Type of contact	
Crimping range	mm <sup>2</sup>
Crimping range 1 (with multiple crimping positions)	mm <sup>2</sup>
Crimping range 2 (with multiple crimping positions)	mm <sup>2</sup>
Crimping range 3 (with multiple crimping positions)	mm <sup>2</sup>
Plug width	-
Tool data	
Length	mm
Weight	g
Note	

### Ordering data

Version
Note

CTI 6 G		
Insulated connector		
Crimping range	0.5...6	
Crimping range 1 (with multiple crimping positions)	0.5...1.5	
Crimping range 2 (with multiple crimping positions)	1.1...2.5	
Crimping range 3 (with multiple crimping positions)	2.6...6	
Length	250	
Weight	747	
Note		
Additional accessories can be found in Chapter J.		

Type	Qty	Order No.
CTI 6 G	1	9202850000

CTI 6		
Insulated connector		
Crimping range	0.5...6	
Crimping range 1 (with multiple crimping positions)	0.5...1.5	
Crimping range 2 (with multiple crimping positions)	1.1...2.5	
Crimping range 3 (with multiple crimping positions)	2.6...6	
Length	250	
Weight	730	
Note		
Additional accessories can be found in Chapter J.		

Type	Qty	Order No.
CTI 6	1	9006120000

## Crimping tools for other contacts

### Crimping tools for other contacts

- Ratchet for precise crimping.
- Release option in the event of incorrect operation
- With stop for exact positioning of the contacts.
- Tested according to DIN EN 60352 part 2

#### HTI 15

0.5...2.5 mm<sup>2</sup>



For PVC, PC, and polyamide insulated connectors  
**0.5...2.5 mm<sup>2</sup>**  
 (~AWG 20 ... AWG 14)

- Double-crimp profile, for crimping contact and insulation in one step



#### HTN 21

0.5...6 mm<sup>2</sup>



For uninsulated cable lugs and connectors  
**0.5...6 mm<sup>2</sup>**  
 (AWG 20...10)

- Rolled cable lugs, for example acc. to DIN 46234
- Tubular cable lugs
- Pin cable lugs
- Parallel and serial connectors
- Indent crimp
- Alternatively available with or without pivoting end stop



### Technical data

Description of contact	
Type of contact	
Crimping range	mm <sup>2</sup>
Crimping range 1 (with multiple crimping positions)	mm <sup>2</sup>
Crimping range 2 (with multiple crimping positions)	mm <sup>2</sup>
Crimping range 3 (with multiple crimping positions)	mm <sup>2</sup>
Plug width	-
Tool data	
Length	mm
Weight	g
Note	

### Ordering data

Version
Note

HTI 15		
Insulated connector		
Crimping range	mm <sup>2</sup>	0.5...2.5
Crimping range 1 (with multiple crimping positions)	mm <sup>2</sup>	0.5...1.5
Crimping range 2 (with multiple crimping positions)	mm <sup>2</sup>	1.1...2.5
Crimping range 3 (with multiple crimping positions)	mm <sup>2</sup>	
Plug width		
Length	mm	200
Weight	g	434
Note		

Type	Qty	Order No.
HTI 15	1	9014400000
Note		
Additional accessories can be found in Chapter J.		

HTN 21		HTN 21 M. AN	
Uninsulated connection		Uninsulated connection	
Crimping range	mm <sup>2</sup>	0.5...6	0.5...6
Crimping range 1 (with multiple crimping positions)	mm <sup>2</sup>	0.5...1.5	0.5...1.5
Crimping range 2 (with multiple crimping positions)	mm <sup>2</sup>	1.1...2.5	1.1...2.5
Crimping range 3 (with multiple crimping positions)	mm <sup>2</sup>	2.6...6	2.6...6
Length	mm	200	200
Weight	g	427	427
Note			
End stop for secure contact positioning in tool			

Type	Qty	Order No.
HTN 21	1	9014610000
HTN 21 with pivoting end stop	1	9014100000
Note		

**Crimping tools for other contacts**

- Ratchet for precise crimping.
- Release option in the event of incorrect operation

**CTN 25 D 4**

10...25 mm<sup>2</sup>



For uninsulated cable lugs and connectors

10...25 mm<sup>2</sup>

- Rolled cable lugs, acc. to DIN 46234
- Pin cable lugs
- Parallel and serial connectors
- Indent crimp form



**CTN 25 D 5**

10...25 mm<sup>2</sup>



For uninsulated cable lugs and connectors

10...25 mm<sup>2</sup>

- Rolled cable lugs, acc. to DIN 46235
- Pin cable lugs
- Parallel and serial connectors
- Hexagon crimp form



**Technical data**

Description of contact	
Type of contact	
Crimping range	mm <sup>2</sup>
Crimping range 1 (with multiple crimping positions)	mm <sup>2</sup>
Crimping range 2 (with multiple crimping positions)	mm <sup>2</sup>
Crimping range 3 (with multiple crimping positions)	mm <sup>2</sup>
Plug width	-
Tool data	
Length	mm
Weight	g
Note	

**Ordering data**

Version
Note

CTN 25 D4		
Uninsulated connection		
Crimping range	mm <sup>2</sup>	10...25
Crimping range 1 (with multiple crimping positions)	mm <sup>2</sup>	10
Crimping range 2 (with multiple crimping positions)	mm <sup>2</sup>	16
Crimping range 3 (with multiple crimping positions)	mm <sup>2</sup>	25
Tool data		
Length	mm	250
Weight	g	730
Note		

Type	Qty	Order No.
CTN 25 D4	1	9006220000
Note		
For rolled cable lugs		

CTN 25 D5		
Uninsulated connection		
Crimping range	mm <sup>2</sup>	10...25
Crimping range 1 (with multiple crimping positions)	mm <sup>2</sup>	10
Crimping range 2 (with multiple crimping positions)	mm <sup>2</sup>	16
Crimping range 3 (with multiple crimping positions)	mm <sup>2</sup>	25
Tool data		
Length	mm	250
Weight	g	730
Note		

Type	Qty	Order No.
CTN 25 D5	1	9006230000
Note		
For tubular cable lugs		

## Crimping tools for other contacts

## Crimping tools for other contacts

- Ratchet for precise crimping.
- Release option in the event of incorrect operation
- With stop for exact positioning of the contacts.

## CTX CM 1.6/2.5 / CTX CM 3.6

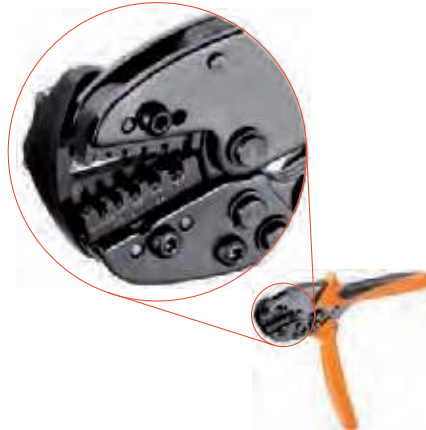
0.14...10 mm<sup>2</sup>

## CTX CM 1.6/2.5

- Turned HD contacts
- Turned HE contacts
- ConCept M10 and M5 contacts
- 0.14...4.0 mm<sup>2</sup>

## CTX CM 3.6

- Turned HD contacts
- ConCept M 3 contacts
- 4.0...10 mm<sup>2</sup>



## CTIN CM 1.6/2.5 / CTIN 3.6

0.14...10 mm<sup>2</sup>

## CTIN CM 1.6/2.5

- Turned HD and HE contacts
- Turned HX contacts
- ConCept M10, M5 and M3 contacts
- 4-indent crimp
- 0.14...6.0 mm<sup>2</sup>

## CTIN CM 3.6

- Turned HX contacts
- ConCept M 3 contacts
- 4-indent crimp
- 1.5...10.0 mm<sup>2</sup>



## Technical data

Description of contact	
Type of contact	
Crimping range	mm <sup>2</sup>
Crimping range 1 (with multiple crimping positions)	mm <sup>2</sup>
Crimping range 2 (with multiple crimping positions)	mm <sup>2</sup>
Crimping range 3 (with multiple crimping positions)	mm <sup>2</sup>
Crimping range 4 (with multiple crimping positions)	mm <sup>2</sup>
Crimping range 5 (with multiple crimping positions)	mm <sup>2</sup>
Tool data	
Length	mm
Weight	g
Note	

## Ordering data

Version
Note

CTX CM 1.6/2.5	CTX CM 3.6
Turned contacts	Turned contacts
0.14...4	4...10
0.14...0.5	4
0.75...1	6
1.5	10
2.5	
4	
250	250
730	730
Note	

Type	Qty	Order No.
CTX CM 1.6/2.5	1	9018490000
CTX CM 3.6	1	9018480000

A large selection of contacts can be found in our current Heavy-Duty Connectors Catalogue.

CTIN CM 1.6/2.5	CTIN CM 3.6
Turned HD, HE HX +Concept M10, M5, M3 HX turned and Concept M3 contacts	
0.14...6	1.5...10
0.14...6	1.5...10
230	230
1220	1220
Note	

Type	Qty	Order No.
CTIN CM 1.6/2.5	1	9205430000
CTIN CM 3.6	1	9205440000

A large selection of contacts can be found in our current Heavy-Duty Connectors Catalogue.



**Crimping tools for other contacts**

- Ratchet for precise crimping.
- Release option in the event of incorrect operation

**HTX LWL**



For fibre-optic cables with

- core diameter of 1 mm
- Crimping sleeve Ø 5.5 mm

**Station 1:** Hexagon crimp

**Station 2:** Round crimp (for HP connectors)



**Technical data**

Description of contact	
Type of contact	
Station 1: A / B	mm
Station 2: A / B	mm
Station 3: A / B	-
C	-
D	-
Tool data	
Length	mm
Weight	g
Note	

HTX LWL	
Fibre-optic connector	
Station 1: A / B	3.15 / 6
Station 2: A / B	4.85 / 6
C	-
D	-
Tool data	
Length	200
Weight	415
Note	
H.-ø: Sleeve diameter	

**Ordering data**

Version
Note

Type	Qty	Order No.
HTX LWL	1	9011360000

Note

## Crimping tools for other contacts

## Crimping tools for other contacts

- Ratchet for precise crimping.
- Release option in the event of incorrect operation

## IE-CT-SC-GOF / IE-CT-LC-GOF

## Crimping tools for IP 20 + 67 plugs



- For fibre-optic SC/ST, IP 20 and IP 67 connectors
- For fibre-optic LC and IP 67 connectors

## IE-CT-SC-POF / IE-CT-SC-GOF-P

## Crimping tools for IP 20 + 67 plugs



- For polymer fibre-optic SC/ST, IP 20 and IP 67 connectors
- For fibre-optic, ProfiNet, Mobil cable SC/ST and IP 67 connectors



## Technical data

Tool data
Length
Weight
Note

IE-CT-SC-GOF	IE-CT-LC-GOF
Length	250
Weight	730
Note	

IE-CT-SC-POF	IE-CT-SC-GOF-P
Length	250
Weight	730
Note	

## Ordering data

Version
Note

Type	Qty	Order No.
IE-CT-SC-GOF	1	9205320000
IE-CT-LC-GOF	1	9205330000

Type	Qty	Order No.
IE-CT-SC-POF	1	9205340000
IE-CT-SC-GOF-P	1	9205350000

## Accessories

Version
Note

Type	Qty	Order No.
IE-CTI-SC-GOF	1	9205280000
IE-CTI-LC-GOF	1	9205290000

A large selection of plugs and connectors can be found in our current Industrial Ethernet Catalogue.

Type	Qty	Order No.
IE-CTI-SC-POF	1	9205300000
IE-CTI-SC-GOF-P	1	9205310000

A large selection of plugs and connectors can be found in our current Industrial Ethernet Catalogue.

**Crimping tools for other contacts**

- Ratchet for precise crimping.
- Release option in the event of incorrect operation

**HTG174 / HTX138 / HTX188**



For coaxial connectors such as BNC, TNC and N plugs

- **HTX 138**  
for connectors on Twinax coaxial cable

**HTG 58 / HTG 59 / HTG 58/59**



For coaxial connectors such as BNC and TNC plugs

- With cables RG 58, RG 59, RG 62, RG 71....

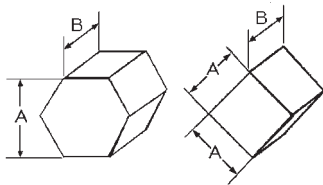

A = Width across flats  
 B = Crimping width  
 C = Ø Outer sleeve of the coaxial plug  
 D = Ø Centre contact



**Technical data**

Description of contact	
Type of contact	
Station 1: A / B	mm
Station 2: A / B	mm
Station 3: A / B	-
C	mm
D	mm
Tool data	
Length	mm
Weight	g
Note	

HTG 174	HTX 138	HTX 188
Coaxial connector	Coaxial connector	Coaxial connector
4.52 / 10	8.24 / 10	3.25 / 10
1.72 / 2.3	1.72 / 2.3	1.72 / 2.3
5.4	9.5	3.8
2	2	2
200	200	200
420	420	420
Note		

HTG 58	HTG 58/59	HTG 59
Coaxial connector	Coaxial connector	Coaxial connector
5.4 / 10	5.4 / 10	6.48 / 10
1.72 / 2.3	6.48 / 10	1.72 / 2.3
6.2	1.72 / 2.3	7.5
2	6.2/7.5	2
200	2	200
420	420	420
Note		

**Ordering data**

Version
Note

Type	Qty	Order No.
HTG 174	1	9012410000
HTX 138	1	9012400000
HTX 188	1	9011990000
Note		

Type	Qty	Order No.
HTG 58	1	9012000000
HTG 58/59	1	9012020000
HTG 59	1	9012010000
Note		







## Pressing tools

### Pressing tools

- Pressing tool for modular plug connectors of the WE system (Western Electric and DEC)
- Ratchet for precise crimping.
- Release option in the event of incorrect operation

#### Three functions:

- Pressing of plug connectors
- Pressing of enclosure shielding
- Crimping of cable shielding

### TT 8 GH



For 8-pole (RJ45) shielded plug (Hirose) for shielded data cables

AWG 28...24

### TT 8 RS MP 8



For 8-pole shielded RJ45 plug

AWG 27...24

Pressing of IDC contacts



Pressing of shielded enclosures



Crimping of shielded cable



### Technical data

Description of contact	
No. of poles	
Tool data	
Length	mm
Weight	g
Note	

TT 8GH		
No. of poles	8	
Length	260	
Weight	750	
Note		

TT 8 RS MP 8		
No. of poles	8	
Length	255	
Weight	1251	
Note		

### Ordering data

Version	
Note	

Type	Qty	Order No.
TT 8GH	1	9005640000
Note		

Type	Qty	Order No.
TT 8 RS MP 8	1	9202800000
Note		

A large selection of RJ 45 plugs can be found in our current Industrial Ethernet Catalogue.

### Pressing tools

- Pressing tool for the WE (Western Electric) and DEC modular connector systems
- Ratchet for precise crimping.
- Release option in the event of incorrect operation

#### 3 functions:

- Cutting
- Stripping
- Crimping

### TT 864 RS WE

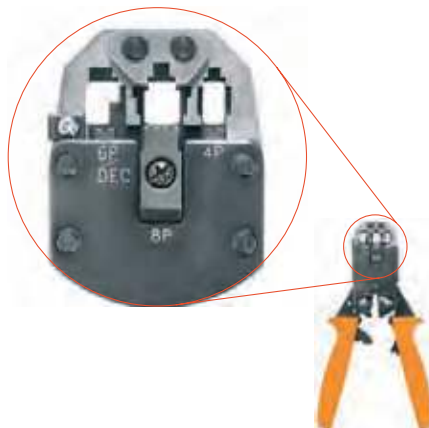

For up to 8-pole flat ribbon or flat-oval data cables

#### AWG 28...24

- For attachment of:
  - 4-pole WE plugs
  - 6-pole (RJ12) WE plugs
  - 6-pole (DEC) WE plugs
  - 8-pole (RJ45) WE plugs
- Triple crimping for RJ45
- For AMP plugs or versions with similar design
- Other versions on request

### TT 1064 RS WE

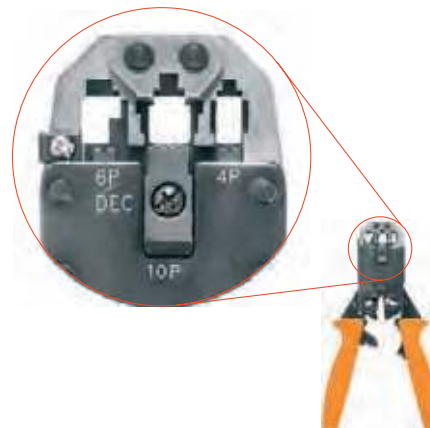

For up to 10-pole flat ribbon or flat-oval data cables

#### AWG 28...24

- For attachment of:
  - 4-pole WE plugs
  - 6-pole (RJ12) WE plugs
  - 6-pole (DEC) WE plugs
  - 10-pole (RJ45) WE plugs
- Triple crimping for RJ45
- For AMP plugs or versions with similar design
- Other versions on request

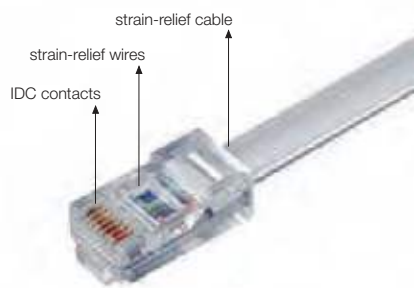

### Technical data

<b>Description of contact</b>	
No. of poles	
<b>Tool data</b>	
Length	mm
Weight	g
<b>Note</b>	

<b>TT 864 RS</b>		
4, 6 and 8		
205		
525		
<b>Note</b>		

<b>TT 1064RS</b>		
10, 6 and 4		
205		
531		
<b>Note</b>		

### Ordering data

<b>Version</b>		
<b>Note</b>		

Type	Qty	Order No.
TT 864 RS	1	9008120000

Type	Qty	Order No.
TT 1064RS	1	9008190000

### Accessories

<b>Note</b>		
-------------	--	--

Type	Qty	Order No.
Spare blade set TT 864	1	9008130000

Type	Qty	Order No.
Spare blade set TT 864	1	9008130000

## Crimping tools for connectors

### Crimping tools for connectors

- For insulated and uninsulated cable lugs and connectors
- Mechanical function ensures safe and manageable operations under different environmental conditions
- Precision engineering means high pressing force with little physical effort
- Fast feed helps pre-centering and extraction of the connecting parts
- Ratchet for proper trouble-free crimping
- Release option in the event of incorrect operation
- Comprehensive range of crimp inserts conforming with standards

### MTR 35 / MTR 110

6...120 mm<sup>2</sup>



- Tubular cable lugs ranging from 6...120 mm<sup>2</sup>
- Rolled CU-connectors ranging from 6...70 mm<sup>2</sup>
- Wire-end ferrules ranging from 25...95 mm<sup>2</sup>
- Retractable head for easy withdrawal of crimped connection

### MTR 160 / MTR 300

10...300 mm<sup>2</sup>



- Tubular cable lugs ranging from 10...300 mm<sup>2</sup>
- Rolled CU connectors ranging from 10...150 mm<sup>2</sup>
- Retractable head for easy withdrawal of crimped connection (only MTR 300)

### MTR 300

Turntable presses: 25...240 ms; 35...240 sec



### Technical data

Description of contact	
Pressing force / Deviation	kN/mm
Crimping range for copper connector (rolled)	mm <sup>2</sup>
Crimping range for copper tube connector	mm <sup>2</sup>
Crimping range for insulated connectors	mm <sup>2</sup>
Crimping range of wire end ferrule	mm <sup>2</sup>
Tool data	
Length / Weight	mm/kg
Note	

MTR 35	MTR 110
25 / 8	55 / 10
6...35	6...70
6...50	10...120
10...25	10...35
25...50	70...95
Tool data	
270 / 1.3	420 / 2
For more details see crimp inserts on the following pages	

MTR 160	MTR 300
100 / 16	100 / 16
10...150	10...150
10...240	10...300
	10...120
Tool data	
540 / 4	540 / 4
For more details see crimp inserts on the following pages sm: sector conductor stranded; se: sector single conductor	

### Ordering data

Version	
Note	

Type	Qty	Order No.
MTR 35	1	9017500000
MTR 110	1	9018020000
Note		

Type	Qty	Order No.
MTR 160	1	9021420000
MTR 300	1	9021390000
Note		

### Accessories

Carry cases	
Note	

Type	Qty	Order No.
MTR 35	1	9017840000
MTR 110	1	9018040000
Crimping inserts see on the following pages		

Type	Qty	Order No.
MTR 300	1	9021420000
MTR 160	1	9017270000
Crimping inserts see on the following pages		

**MTR 35**

	Cross-section [mm <sup>2</sup> ]	Code to DIN 48083	Crimping width [mm]	Order No.
Die sets for <b>copper tube</b> cable lugs and connectors <b>DIN 46235</b>				
	6	5	5.5	9017550000
	10	6	5.5	9017560000
	16	8	5.5	9017570000
	25	10	5.5	9017580000
	35	12	5.5	9017590000
	50	14	5.5	9017760000

	Cross-section [mm <sup>2</sup> ]	Code to DIN 48083	Crimping width [mm]	Order No.
Die sets for <b>aluminium tube</b> cable lugs and connectors <b>DIN 46329</b>				
	25	12	7.0	9017600000
	35	14	7.0	9017610000

	Cross-section [mm <sup>2</sup> ]	Crimping width [mm]	Order No.
Die sets for <b>copper tube</b> cable lugs and connectors <b>standard types</b>			
	6	6.0	9017770000
	10	6.0	9017620000
	16	6.0	9017630000
	25	6.0	9017640000
	35	6.0	9017650000
	50	6.0	9017660000

	Cross-section [mm <sup>2</sup> ]	Order No.
Stamp and dies for copper cable lugs and connectors, <b>DIN 46234, DIN 46230</b>		
	<b>Stamp</b>	
	6-35	9017670000
	<b>Die</b>	
	6	9017680000
	10	9017690000
	16	9017700000
	25	9017710000
	35	9017720000
with control mark		

	Cross-section [mm <sup>2</sup> ]	Order No.
Die sets for insulated cable lugs and connectors, <b>DIN 46231, 46237</b>		
	10	9017990000
	16	9018000000
	25	9018010000

	Cross-section [mm <sup>2</sup> ]	Order No.
Stamp and dies for wire end ferrules		
Stamp	25-50	9017970000
Die	25	9017740000
Die	35	9017750000
Die	50	9017540000

**MTR 110**

	Cross-section [mm <sup>2</sup> ]	Code to DIN 48083	Crimping width [mm]	Order No.
Die sets for <b>copper tube</b> cable lugs and connectors <b>DIN 46235</b>				
	10/70	6/16	5.5	9018100000
	16/35	8/12	5.5	9018110000
	25/50	10/14	5.5	9018120000
	95	18	5.5	9018130000
	120	20	5.5	9018140000

	Cross-section [mm <sup>2</sup> ]	Code to DIN 48083	Crimping width [mm]	Order No.
Die sets for <b>aluminium tube</b> cable lugs and connectors <b>DIN 46329</b>				
	16/35	10/14	7.0	9018800000
	25/50	12/16	7.0	9018810000
	70	18	7.0	9018820000

	Cross-section [mm <sup>2</sup> ]	Crimping width [mm]	Order No.
Die sets for <b>copper tube</b> cable lugs and connectors <b>standard types</b>			
	10/70	7.0	9018400000
	16/35	7.0	9018410000
	25/50	7.0	9018420000
	95	5.5	9018430000
	120	5.5	9018440000

	Cross-section [mm <sup>2</sup> ]	Order No.
Stamp and dies for copper cable lugs and connectors, <b>DIN 46234, DIN 46230</b>		
	<b>Stamp</b>	
	6-70	9018500000
	<b>4-way die</b>	
	10/16/25/35	9018600000
	16/25/35/50	9018610000
	<b>2-way die</b>	
	6/50	9018620000
	10/70	9018630000
	<b>Single die</b>	
	70	9018640000
with control mark		

	Cross-section [mm <sup>2</sup> ]	Crimping width [mm]	Order No.
Die sets for insulated cable lugs and connectors, <b>DIN 46231, 46237</b>			
	10	7.0	9018700000
	16	8.0	9018710000
	25	9.0	9018720000
	35	9.5	9018730000
<b>Oval crimp with control mark</b>			
Crimping insert with spring-mounted locator			

	Cross-section [mm <sup>2</sup> ]	Crimping width [mm]	Order No.
<b>Prerounding die sets Cu/Al for sectored cable</b>			
	25/50	12	9018450000
	35/70	12	9018460000
	95	12	9018470000

	Cross-section [mm <sup>2</sup> ]	Order No.
Die sets for wire end ferrules		
	<b>Pair of dies</b>	
	70	9023360000
	95	9023370000

**MTR 160**

	Cross-section [mm <sup>2</sup> ]	Code to DIN 48083	Crimping width [mm]	Order No.
Die sets for <b>copper tube</b> cable lugs and connectors <b>DIN 46235</b>				
	10	6	7.0	9020900000
	16	8	7.0	9020910000
	25	10	7.0	9020920000
	35	12	7.0	9020930000
	50	14	7.0	9020940000
	70	16	7.0	9020950000
	95	18	7.0	9020960000
	120	20	7.0	9020970000
	150	22	7.0	9020980000
	185	25	7.0	9020990000
	240	28	7.0	9021000000

**MTR 300**

	Cross-section [mm <sup>2</sup> ]	Code to DIN 48083	Crimping width [mm]	Order No.
Die sets for <b>copper tube</b> cable lugs and connectors <b>DIN 46235</b>				
	10	6	7.0	9021430000
	16	8	7.0	9021440000
	25	10	7.0	9021450000
	35	12	7.0	9021460000
	50	14	7.0	9021470000
	70	16	7.0	9021480000
	95	18	7.0	9022290000
	120	20	7.0	9022300000
	150	22	7.0	9022310000
	185	25	7.0	9022320000
	240	28	7.0	9022330000
	300	32	7.0	9022340000

**D**

	Cross-section [mm <sup>2</sup> ]	Crimping width [mm]	Order No.
Die sets for <b>copper tube</b> cable lugs and connectors <b>standard types</b>			
	10/25	9.8	9021750000
	16/35	9.8	9021760000
	50	8.0	9021770000
	70	8.0	9021780000
	95	8.0	9021790000
	120	8.0	9021800000
	150	8.0	9021810000
	185	8.0	9021820000
240	8.0	9021830000	

	Cross-section [mm <sup>2</sup> ]	Crimping width [mm]	Order No.
Die sets for <b>copper tube</b> cable lugs and connectors <b>standard types</b>			
	10/25	9.8	9024010000
	16/35	9.8	9024400000
	50	8.0	9024410000
	70	8.0	9024420000
	95	8.0	9024430000
	120	8.0	9025210000
	150	8.0	9025220000
	185	8.0	9025230000
240	8.0	9028020000	

	Cross-section [mm <sup>2</sup> ]	Order No.
Die sets for copper cable lugs and connectors, <b>DIN 46234, DIN 46230</b>		
	10	9021300000
	16	9021310000
	25	9021320000
	35	9021330000
	50	9021340000
	70	9021350000
	95	9021360000
	120	9021370000
	150	9021380000
with control mark		

	Cross-section [mm <sup>2</sup> ]	Order No.
Die sets for copper cable lugs and connectors, <b>DIN 46234, DIN 46230</b>		
	<b>2-way die</b>	
	16/35	9022360000
	10/70	9022350000
	<b>Stamp</b>	
	25/50	9022370000
	<b>Single die</b>	
	10 - 70	9022990000
	<b>Stamp</b>	
	95	9022380000
	120	9022390000
	<b>Stamp</b>	
	150	9022400000
	<b>Stamp</b>	
	95-150	9023110000

	Cross-section [mm <sup>2</sup> ]	Order No.
Die sets for insulated copper cable lugs and connectors, <b>DIN 46231, 46237</b>		
	10	9016180000
	16	9016190000
	25	9016200000
	35	9016210000
	50	9016220000
	70	9016230000
	95	9016240000
	120	9016250000

	Cross-section [mm <sup>2</sup> ]	Order No.
Prerounding die sets Cu/Al for sectored cable		
	25 sm/35 se	9016260000
	35 sm/50 se	9016270000
	50 sm/70 se	9016280000
	70 sm/95 se	9016290000
	95 sm/120 se	9016370000
	120 sm/150 se	9016380000
	150 sm/185 se	9016390000
	185 sm/240 se	9016440000
240 sm	9016500000	

### Insertion tool for twisted-pair cable

For connecting twisted-pair cable to terminal rails with IDC contacts e. g. in main and floor distributors, and in modular wall junction boxes for structured building cabling.

### PDT



The punch-down tool has the following features:

- Mechanics made from metal components
- Adjustable pressing force for conductor sizes AWG 20 to AWG 28
- Different blades for connector blocks of type 110 from AT&T, type 66, type LSA Plus from Krone (Standard and scissors cutting function) as well as for telephone outlets 630A6
- Incision blades with 2 functions: incision or incision with cutting off of remaining conductor
- Storage compartment for one blade



- A = PD blade 110
- B = PD blade 66
- C = PD blade 630
- D = PD blade Krone LSA (standard)
- E = PD blade Krone LSA (scissor)

### Technical data

Length / Width / Height	mm
Weight	g
<b>Note</b>	

<b>PUNCH DOWN TOOL PDT</b>		
Length / Width / Height	160 / 37 / 29	
Weight	142	
<b>Note</b>		

### Ordering data

<b>Version</b>
<b>Note</b>

Type	Qty	Order No.
PUNCH DOWN TOOL PDT	1	9013970000
<b>Note</b>		
(without blade)		

### Accessories

<b>Note</b>
-------------

Type	Qty	Order No.
PD blade Krone LSA Plus (scissor)	1	9014050000
PD blade 110	1	9013960000
PD blade 630	1	9013990000
PD blade 66	1	9013980000
PD blade Krone LSA Plus (standard)	1	9014000000
<b>Note</b>		



## Crimp removal tools

### Removal Tool CM3, CM5, HD

#### CM3 Removal Tool

Contact release tool for freeing crimp contacts in the Concept CM3 module

#### CM5 Removal Tool

Contact release tool for freeing crimp contacts in the Concept CM5 module

#### HD Removal Tool

Contact release tool for freeing crimp contacts in the Concept CM10 module

#### Ordering data

Type	Qty	Order No.
Removal Tool CM 3	1	1866710000
Removal Tool CM 5	1	1866720000
Removal Tool HD	1	1866730000



### Removal Tool M20

Contact release tool for releasing crimp contacts in ConCept CM20 modules

#### Ordering data

Type	Qty	Order No.
Removal Tool CM 20	1	1866740000



## D

### Removal Tool HE

Contact release tool for ConCept HE modules, and for releasing crimp contacts in ConCept CM4 modules

#### Ordering data

Type	Qty	Order No.
Removal Tool HE	1	1866750000



### HDC-DW RSV 1.6

Contact release tool for ConCept modules, or for dismantling stamped HD pin and socket contacts of type CB/CS and GB/GS

#### Ordering data

Type	Qty	Order No.
DW RSV 1.6	1	9004530000



### DFF-C

Disengaging tool for removing crimp contacts clipped in BLAC enclosures

#### Ordering data

Type	Qty	Order No.
DFF-C ENTRIEGELUNGSWZ.	1	9014210000



### Removal Tool AFK

Contact release tool for removing FEKO ZRV contacts.

#### Ordering data

Type	Qty	Order No.
REMOVAL TOOL AFK	1	1866760000



**HTX-HDC/POF****POF crimping**

Crimping of fibre optic contacts „polymer optical fibre“ (POF).

- For plug and socket
- Ratchet for precise crimping.
- Unlocks in case of incorrect operation
- Locator for precise contact positioning

**Contacts:**

- Fibre-optic HD-contact socket for  $\varnothing$  1.0mm POF
- Fibre-optic HD-contact pin for  $\varnothing$  1.0mm POF

**Ordering data**

Type	Qty	Order No.
HTX-HDC/POF	1	9010950000

**Technical data**

Length	200 mm
Weight	438 g

**PB LWL/POF / PS LWL/POF****POF polishing**

For processing the cut surface of fibre-optic cables with polymer optical fibre (POF).

- Buffing disc (PS LWL/POF)
- Buffing sheet (PB LWL/POF)

**Ordering data**

Type	Qty	Order No.
PS LWL/POF	1	9020390000
PB LWL/POF	1	9020400000

**AM LWL/POF****POF stripping**

Stripping fibre-optic cables. Fibre-optic cables with polymer optical fibre (POF).

- Longitudinal stop with scale is built into the tool
- Stripping direction is lengthwise to the fibre
- No damage to the optical fibre

**Ordering data**

Type	Qty	Order No.
AM LWL/POF	1	9020360000

**LWL-stripax**

Stripping and cutting tool for plastic fibre-optic cables with 1-mm diameter inner conductor

- Stripping length adjustable via end stop
- Automatic opening of the clamping jaws after stripping

**Ordering data**

Type	Qty	Order No.
M-D-STRIPAX LWL	1	9003750000

**Accessories**

Type	Qty	Order No.
Spare stripping blades LWL-Stripax	1	9003760000

**Technical data**

Max. stripping performance	
Cable type	
Conductor diameter	-
Stripping length, max.	-
Tool data	
Length	mm
Weight	g
Note	

M-D-STRIPAX LWL	
POF conductor with an inner conductor of 1 mm $\varnothing$	
...	1
...	7.5
...	135
...	110
POF: polymer optical fibre	



## Cable tie tools

## Cable tie tools

## RT 1



For plastic cable ties of 2.5...4.8 mm width and with a thickness of max. 1.6 mm.

- Tensioning and separating of cable ties in one step
- The tensioning force can be adjusted over a wide range to cover small to standard cable ties.
- For cable bundles of 1.6 mm to 100 mm diameter



## Technical data

Length	mm
Weight	g
<b>Note</b>	

<b>CABLE TIE TOOL RT-1</b>		
Length	mm	160
Weight	g	260
<b>Note</b>		

## Ordering data

<b>Version</b>	
<b>Note</b>	

Type	Qty	Order No.
CABLE TIE TOOL RT-1	1	1296000000
<b>Note</b>		

## WSM tool automatic



For steel cable ties with a width of 4.6 mm

- Tensioning and automatic separation of leftover cable tie in one step
- For steel cable ties, e.g., Weidsteel from Weidmüller



<b>WSM TOOL AUTOMATIC</b>		
Length	mm	275
Weight	g	579
<b>Note</b>		

Type	Qty	Order No.
WSM TOOL AUTOMATIK	1	1774470000
<b>Note</b>		

Cable tie tools

WSM tool manual



For steel cable ties with a width of 4.6 mm

- For tensioning steel cable ties. The surplus end is then broken off by twisting it 90°.



Technical data

Length	mm
Weight	g
<b>Note</b>	

<b>WSM TOOL MANUAL</b>		
Length	mm	220
Weight	g	633
<b>Note</b>		

Ordering data

<b>Version</b>
<b>Note</b>

Type	Qty	Order No.
WSM TOOL MANUELL	1	1774480000

<b>Note</b>
-------------

