

LOC		DIST		REVISIONS				DATE	APPD
ZONE	LTR	DESCRIPTION	DATE	APPD					
CE	16			G	REV PER	0A00-0318-96	7-8-96	DDE	

1 CONNECTOR ASSY: AL, CERAMIC
 BOOT: THERMOPLASTIC ELASTOMER
 STEPPED SLEEVE: BRASS/COPPER
 PLUNGER: AL

2 STEPPED SLEEVE: Ni

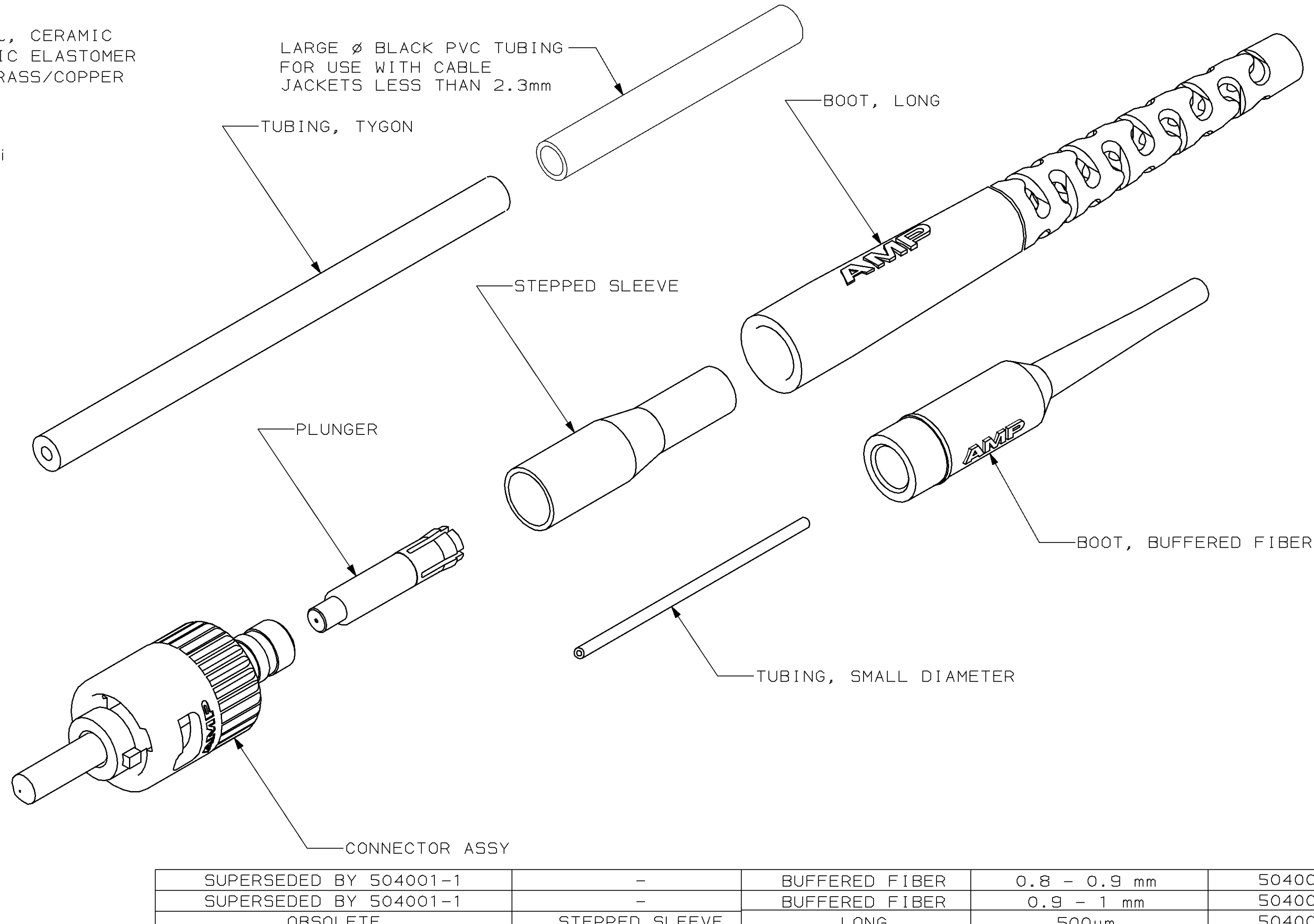

SUPERSEDED BY 504001-1	-	BUFFERED FIBER	0.8 - 0.9 mm	504001-6
SUPERSEDED BY 504001-1	-	BUFFERED FIBER	0.9 - 1 mm	504001-5
OBSOLETE	STEPPED SLEEVE	LONG	500µm	504001-4
SUPERSEDED BY 504001-1	-	BUFFERED FIBER	250µm	504001-3
SUPERSEDED BY 504001-1	STEPPED SLEEVE	LONG	0.8 - 0.9 mm	504001-2
SUPERSEDED BY 504001-1	STEPPED SLEEVE	LONG/ BUFFERED	250µm/ 0.8 - 1 mm	504001-1
	CRIMP SLEEVE	BOOT TYPE	BUFFER SIZE	PART NO

DO NOT SCALE PRINT. UNLESS SPECIFIED DIMENSIONS IN mm [INCHES] TOLERANCES ON : 2 PLC DEC ± - 3 PLC DEC ± - ANGLES ± -	DR 8-29-92 D ERDMAN	AMP AMP Incorporated Harrisburg, PA 17105-3608		
MATERIAL	CHK 8-29-92 B EDWARDS			
FINISH	APPD 9-21-92 S GRINDERSLEV	NAME KIT, CONNECTOR, 125µm 2.5mm BAYONET, XTC MULTIMODE		
	APPD 8-29-92 K MONROE	SIZE	CAGE CODE	DRAWING NO
	PRODUCT SPEC	C	00779	G=504001
	APPLICATION SPEC	SCALE	-	SHEET 1 OF 1
	WEIGHT	-	-	-

THIS DRAWING IS A CONTROLLED DOCUMENT FOR AMP INCORPORATED. IT IS SUBJECT TO CHANGE AND THE CONTROLLING ENGINEERING ORGANIZATION SHOULD BE CONTACTED FOR THE LATEST REVISION.