

**iPass+™
HSC
Stack Dual-Port
Removal Tool**

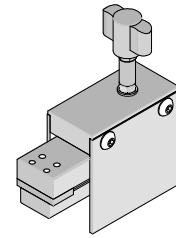

**Application Tooling
Specification Sheet**



Order No. 62203-0430

FEATURES

- Lightweight tool used to remove the iPass+™ CXP (short) connector assembly from a PCB
- Removes connector from in a PCB without damage to the board
- Use tool 62203-0420 for inserting connectors

SCOPE

Products: iPass+™ HSC Stack Dual-Port Integrated Cage and Connector Assembly, 168 Circuit, Press-Fit. See Product List below for specific part numbers.

Product List

The following is a partial list of the product order numbers and their specifications this tool is designed to run. Updates to this list are available on www.molex.com.

Connector Series No.	Assembly Order No.	
76024	76024-0568	76024-0569

Tool Setup

The tooling arrangement in this removal tool is determined by the module and component placement on the PCB. There is a “Keep-Out Zone” that needs to be clear of the other components when using the extraction tool. See the shaded area in Figure 1.

Note: Be sure that all parts of the removal tool will clear any components on the printed circuit board during use. Tape may be placed over circuit traces or on the bottom of the side plates for added protection of the printed circuit board.

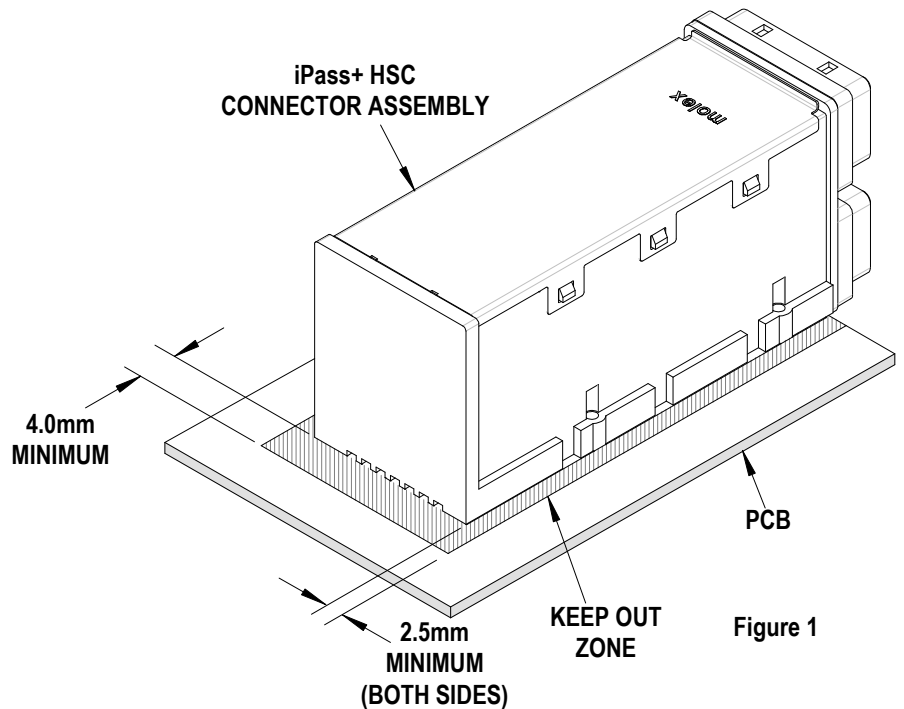
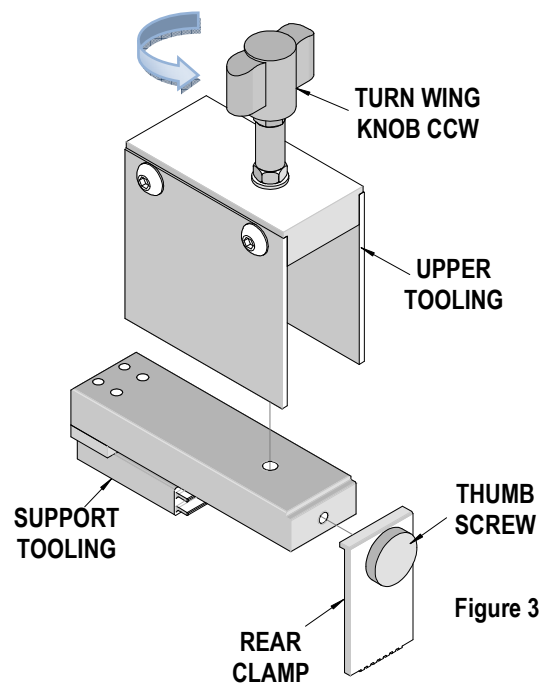
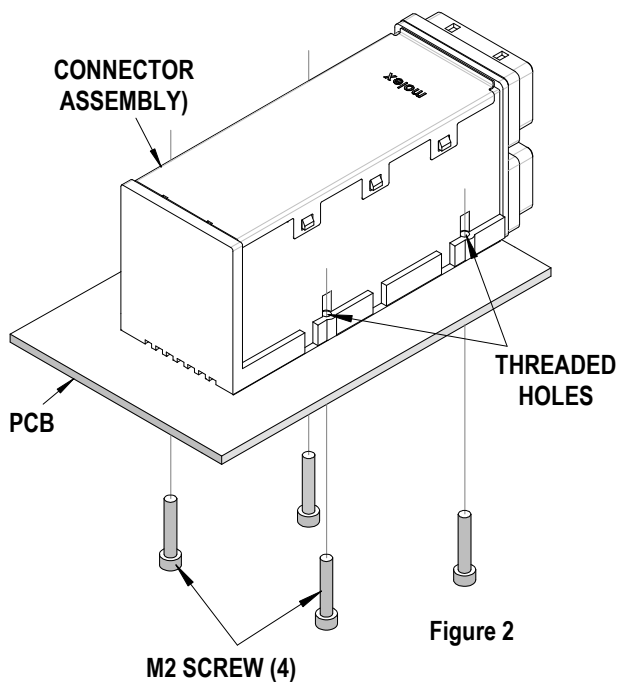

Figure 1

Note: M2 screws must be removed before removing the connector.

The connector assembly is held to the printed circuit board with (4) M2 screws. Before any removal operation is done, these M2 screws must be removed. See Figure 2.



Operation

1. Disassemble the upper tooling from the support tooling by turning the wing knob counterclockwise (CCW) until the halves separate.
2. Remove the rear clamp by turning the thumb screw counterclockwise (CCW). See Figure 3.
Note: the thumb screw is captive in the rear clamp to prevent loss.
3. Insert the support tooling into the connector assembly until it is fully seated. See Figure 4. The tooling will “snap” into the connector when fully seated.

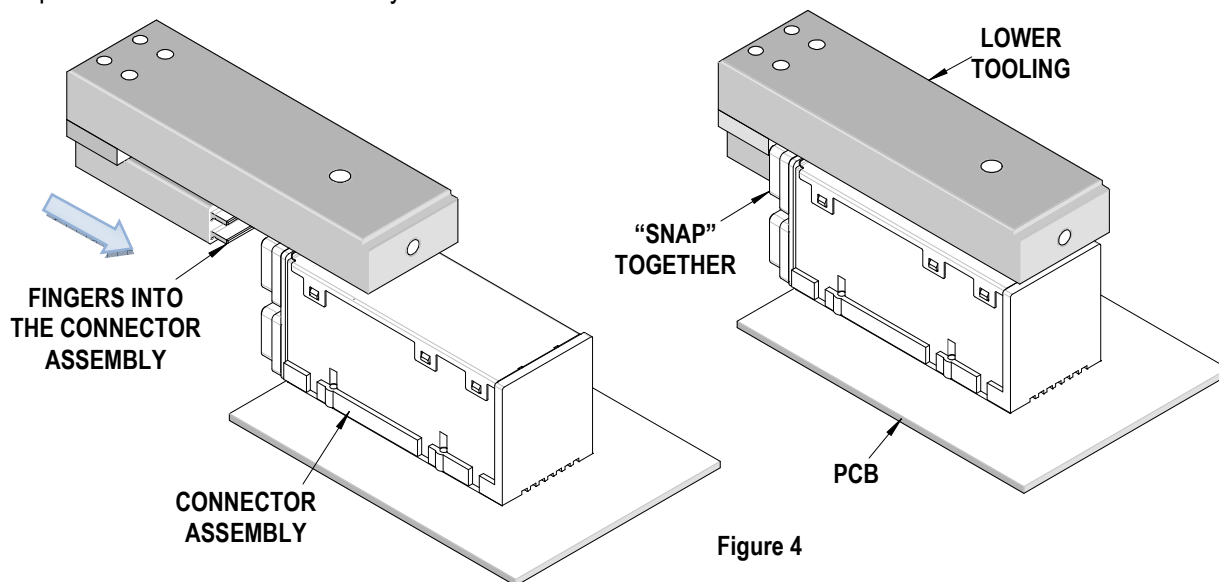

4. Place the rear clamp on the support tooling and tighten the thumb screw. The teeth of the rear clamp must engage the edge of the connector. See Figure 5.
5. Place the upper tooling over the support tooling, so the lift screw is in line with the threaded hole in the support tooling. See Figure 5.

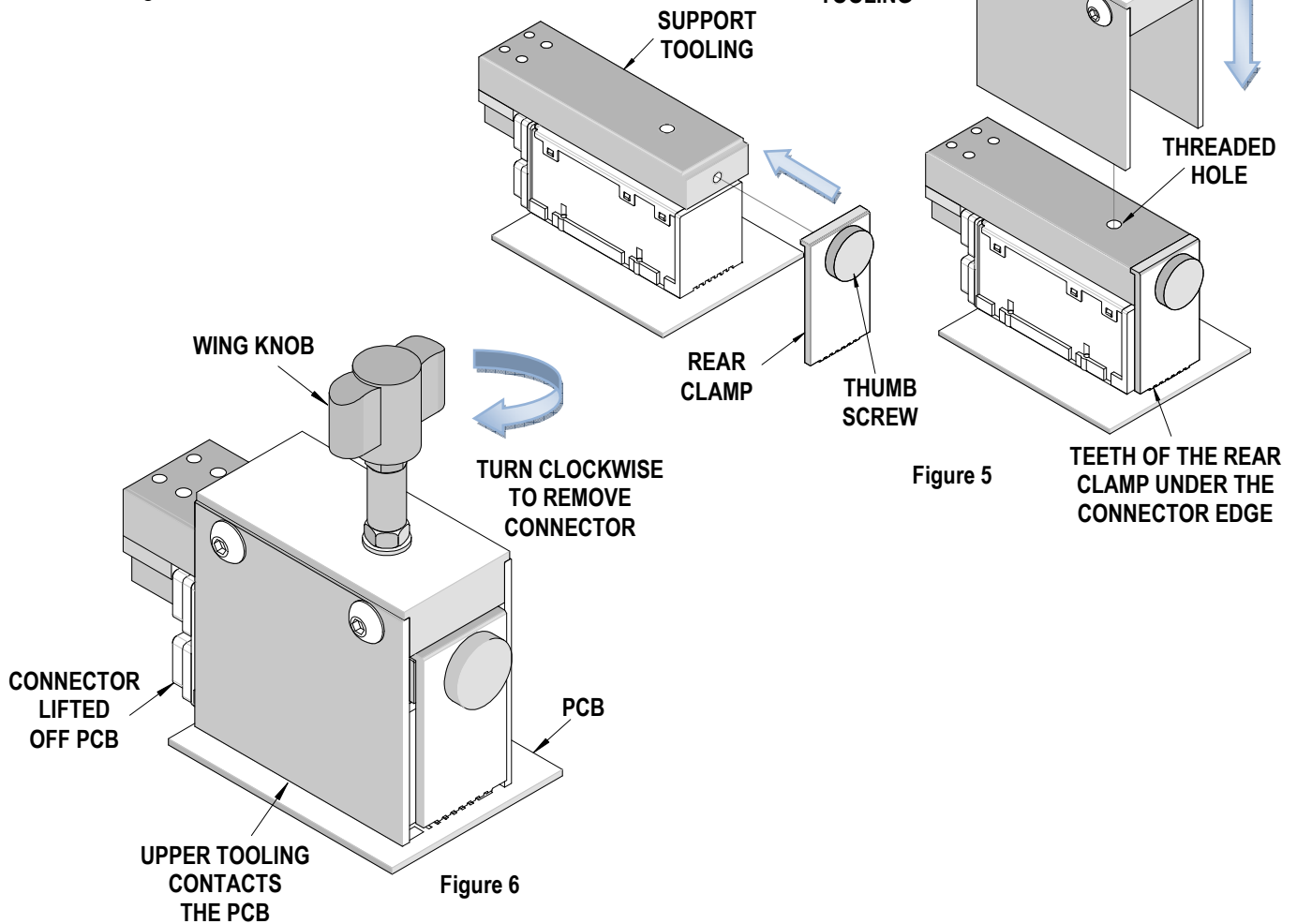

6. Turn the wing knob clockwise until the sides of the upper tooling contact the PCB. Continue turning until the connector is removed from the PCB. See Figure 6.

CAUTION: Molex application tooling specifications are valid only when used with Molex connectors and tooling.

Contact Information

For more information on Molex application tooling please contact Molex at 1-800-786-6539.

<http://www.molex.com>