

HIGH PRESSURE CONNECTORS

 SERIES



 **LEMO**[®]

Precision modular connectors to suit your application

Since its creation in Switzerland in 1946 the LEMO Group has been recognized as a global leader of circular Push-Pull connectors and connector solutions. Today LEMO and its affiliated companies, REDEL and COELVER, are active in more than 80 countries with the help of over 40 subsidiaries and distributors.

Over 50'000 connectors

The modular design of the LEMO range provides over 50'000 connectors from miniature \varnothing 3 mm to \varnothing 50 mm, capable of handling cable diameters up to 30 mm and for up to 106 contacts.

This vast portfolio enables you to select the ideal connector configuration to suit almost any specific requirement in most markets, including medical devices, test and measurement instruments, machinery, audio video broadcast, telecommunications and military.

LEMO's Push-Pull Self-Latching Connection System (not shown in this catalogue)

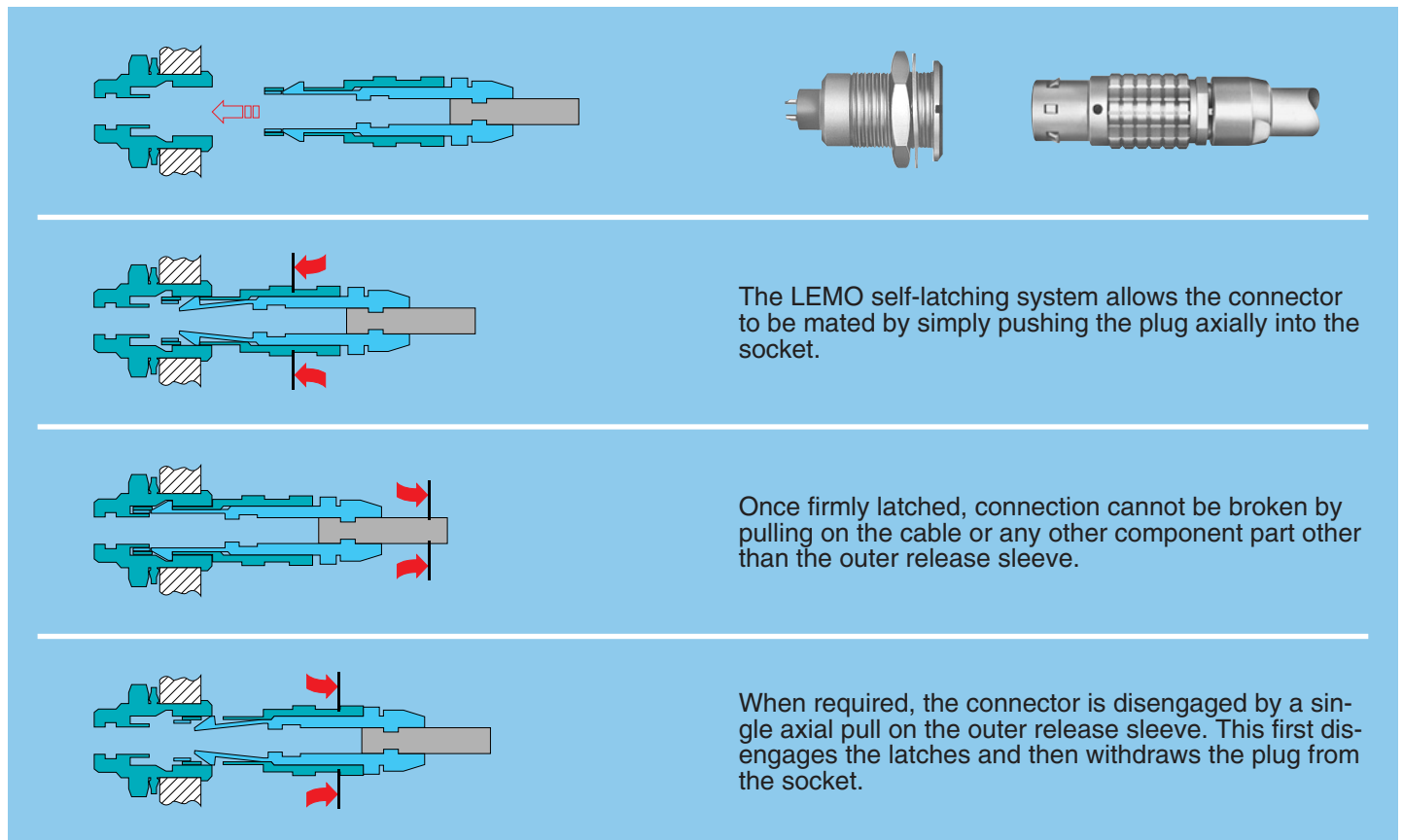

This self-latching system is renowned worldwide for its easy and quick mating and unmating features. It provides absolute security against vibration, shock or pull on the cable, and facilitates operation in a very limited space.



UL Recognition

LEMO connectors are recognized by the Underwriters Laboratories (UL). The approval of the complete system (LEMO connector, cable and your equipment) will be easier because LEMO connectors are approved.

CE marking

CE marking  means that the appliance or equipment bearing it complies with the protection requirements of one or several European safety directives. CE marking  applies to complete products or equipment, **but not to electromechanical components, such as connectors.**

RoHS

LEMO connector specifications exceed the requirements of the RoHS directives (2002/95/EC) of the European Parliament and the latest amendments. This directive specifies the restrictions of the use of hazardous substances in electrical and electronic equipment marketed in Europe. LEMO guarantees that its connectors are free of mercury, cadmium, lead, hexavalent chromium and polybromide biphenyl (PBB), polybromide diphenyl ether (PBDE), or DecaBDE.

03 Series

This series of connectors stems from the series 00 and has been specifically developed for applications where the connection must be guaranteed under very high pressure. The push-pull latching system has been replaced by a screw coupling system with watertightness maintained by compression of an O-ring in FPM (Viton®) according to the triangular shaped cavity principle. There are multiple application possibilities, from aerospace to the petroleum industry.

After cable assembly, the rear part must be covered with an adhesive heatshrink boot in order to ensure watertightness on the cable side. 03 series connectors provide the following main features:

- coaxial 50 Ω type
- multipole with 2, 3 or 4 contacts
- 360° screening for full EMC shielding
- rugged housing for extreme working conditions
- working pressure that can exceed 60 bars in mated conditions

Multipole Type (302, 303, 304)

Models (page 3)

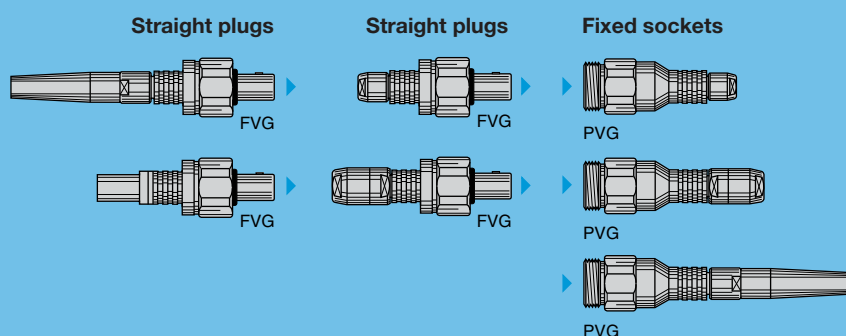

Vacuumtight models (page 5)

Fixed sockets Free sockets

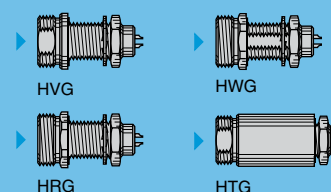

Coaxial Type (50 Ω)

Models (page 6)

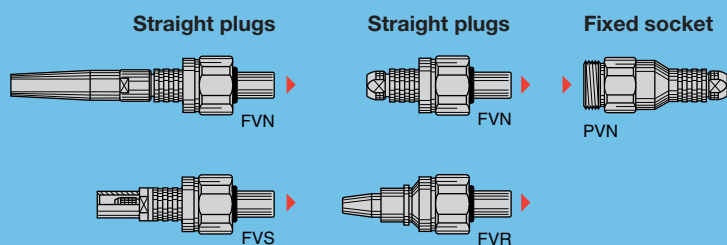

Vacuumtight models (page 8)

Fixed sockets Free sockets

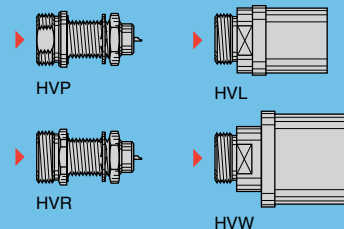

Part Numbering System

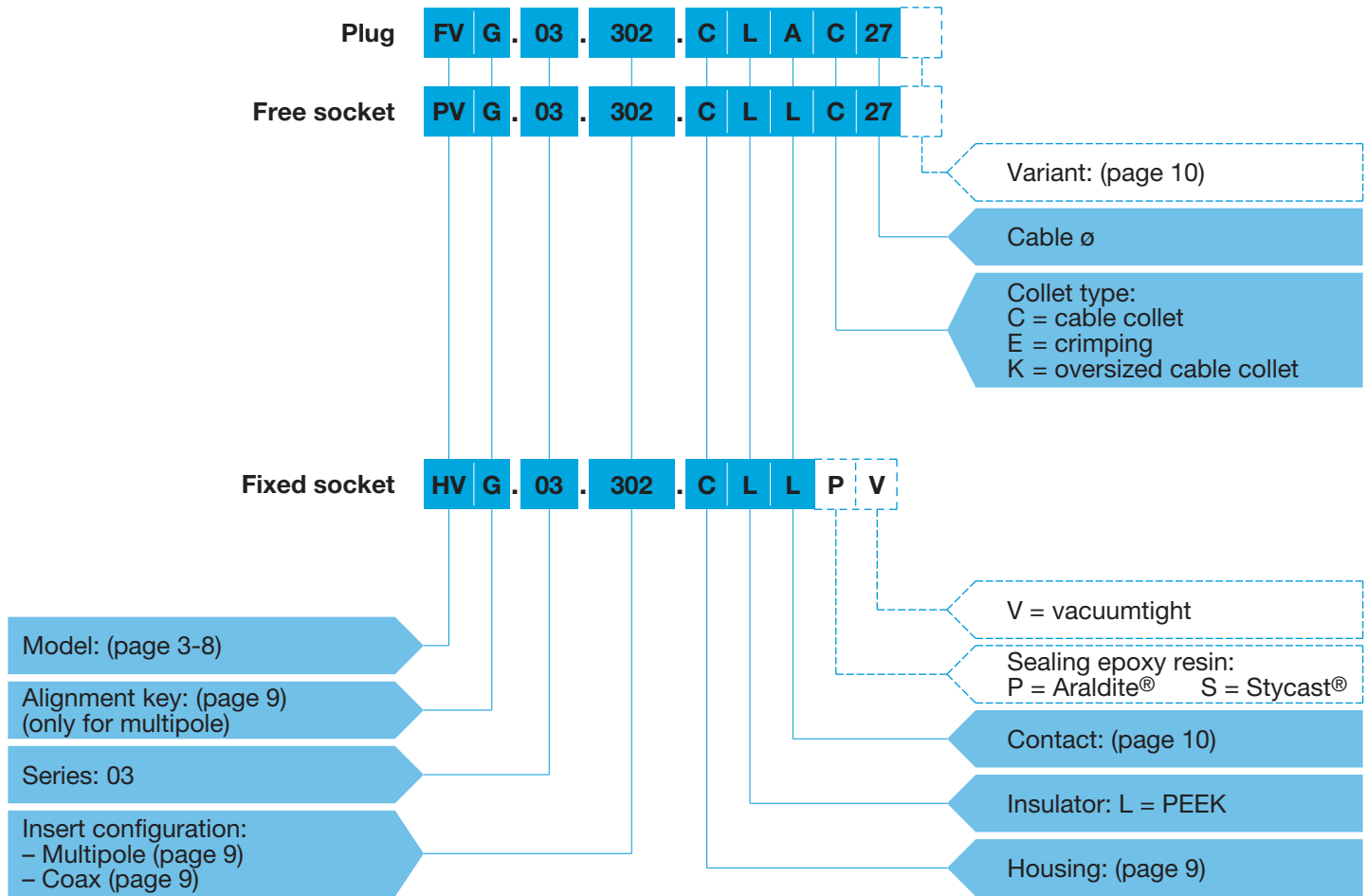

Part Number Example

Straight plug with cable collet:

FVG.03.302.CLAC27 = straight plug with key (G) and cable collet, 03 series, multipole type with 2 contacts, outer shell in chrome-plated brass, PEEK insulator, male solder contacts, C type collet for 2.7 mm diameter cable.

Free socket:

PVG.03.302.CLLC27 = free socket with key (G) and cable collet, 03 series, multipole type with 2 contacts, outer shell in chrome-plated brass, PEEK insulator, female solder contacts, C type collet for 2.7 mm diameter cable.

Fixed socket:

HVG.03.302.CLLPV = fixed socket, nut fixing, with key (G), 03 series, multipole type with 2 contacts, outer shell in chrome-plated brass, PEEK insulator, female solder contacts, sealed with Araldite® epoxy resin.

Part Section Showing Internal Components (multipole)

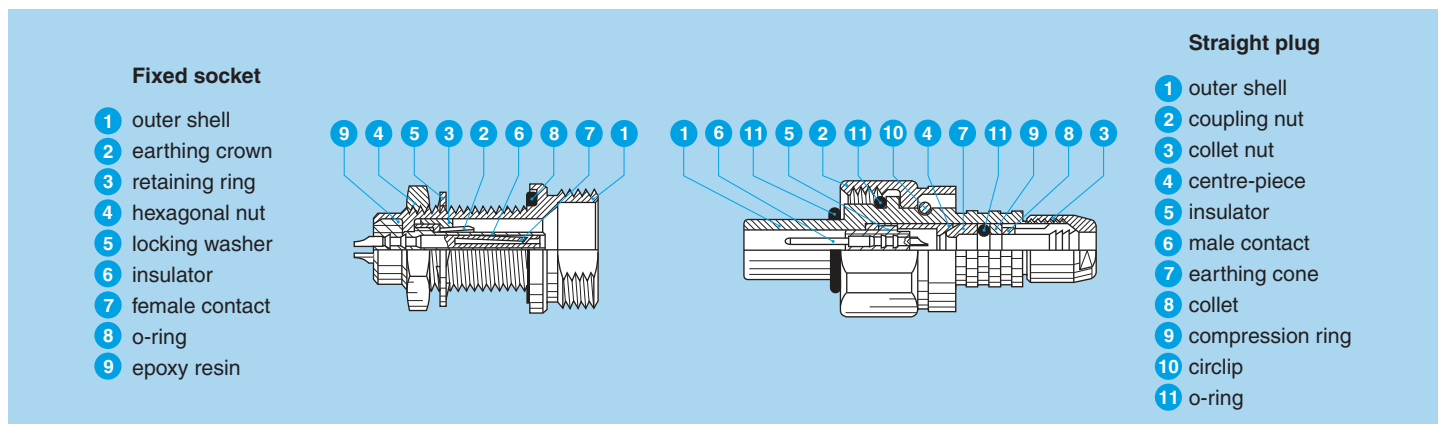

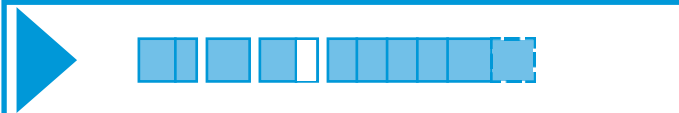

Models (multipole type)

Technical Characteristics

Mechanical and Climatical

Characteristics	Value	Standard
Endurance	> 1000 cycles	IEC 60512-5 test 9a
Humidity	up to 95% at 60° C	
Temperature range	-20° C, +200° C	
Salt spray corrosion test	> 144 h	IEC 60512-6 test 11f
Protection index ²⁾	> IP68	IEC 60529
Resistance to hydrostatic pressure ²⁾	~ 60 bars ¹⁾	IEC 60512-7 test 14d
Climatical category	20/200/21	IEC 60068-1

Note:

¹⁾ in order to perform correctly and withstand the pressure, cable assembly shall be made according to instruction we recommend. See page 11.
²⁾ For mated plug and socket.

Electrical

Characteristics	Value	Standard	Section
Insulation resistance (new)	> 10 ¹² Ω	IEC 60512-2	test 3a
Insulation resistance ³⁾	> 10 ¹⁰ Ω	IEC 60512-2	test 3a
Shell electrical continuity	5.0 mΩ	IEC 60512-2	test 2f
Shielding efficiency	at 10 MHz	> 100 dB	IEC 60169-1-3
	at 1 GHz	> 80 dB	IEC 60169-1-3
Contact resist. ⁴⁾	∅ A = 0.5 mm	≤ 8.7 mΩ	test 2a
Contact resist. ⁴⁾	∅ A = 0.7 mm	≤ 6.1 mΩ	test 2a

Note:

³⁾ after humidity test: 21 days at 95% RH according to IEC 60068-2.
⁴⁾ after 5000 mating cycles and the salt spray test according to IEC 60512-6 test 11 f.

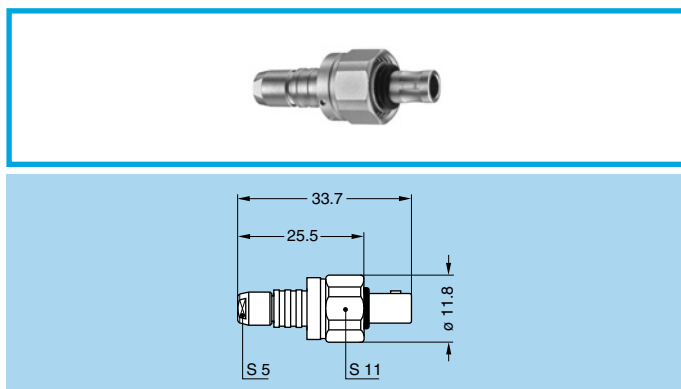

FVG Straight plug, key (G) or key (B), cable collet

Part number	Cable ∅ (mm)	
	min.	max.
FVG.03.30●.CLAC27	2.4	2.6
FVG.03.30●.SLAC27	2.4	2.6
FVG.03.30●.CLAC31	2.7	3.0
FVG.03.30●.SLAC31	2.7	3.0

Note: ● = insert configuration (page 9)

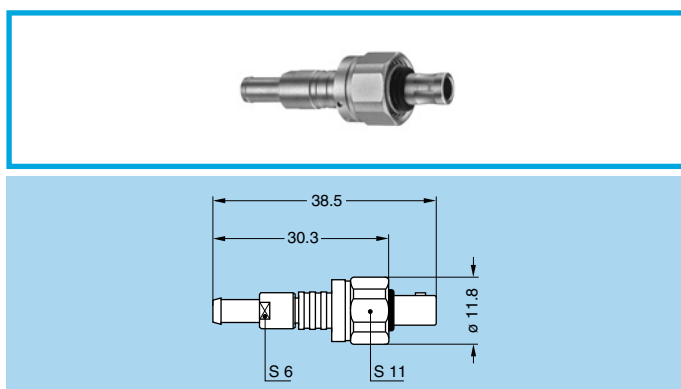

FVG Straight plug, key (G) or key (B), cable collet and nut for fitting a bend relief

Part number	Cable ∅ (mm)	
	min.	max.
FVG.03.30●.CLAC27Z	2.4	2.6
FVG.03.30●.SLAC27Z	2.4	2.6
FVG.03.30●.CLAC31Z	2.7	3.0
FVG.03.30●.SLAC31Z	2.7	3.0

Note: ● = insert configuration (page 9).
 The bend relief must be ordered separately (page 10)

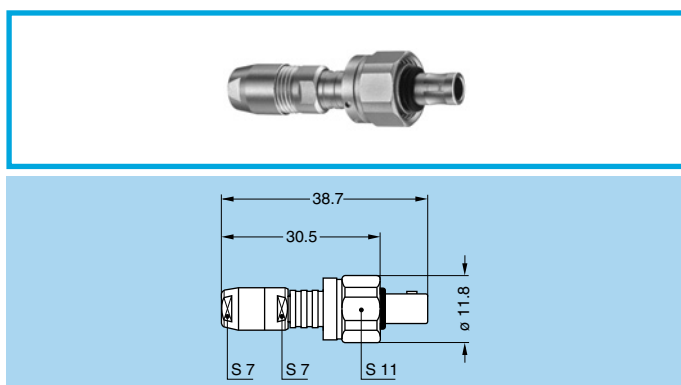

FVG Straight plug, key (G) or key (B) and oversized cable collet

Part number	Cable ∅ (mm)	
	min.	max.
FVG.03.30●.CLAK35	3.1	3.5
FVG.03.30●.CLAK40	3.6	4.0
FVG.03.30●.CLAK45	4.1	4.5
FVG.03.30●.CLAK50	4.6	5.0

Note: ● = insert configuration (page 9)
 Correspond to K type of collet.
 Also available with nut for fitting a bend relief.

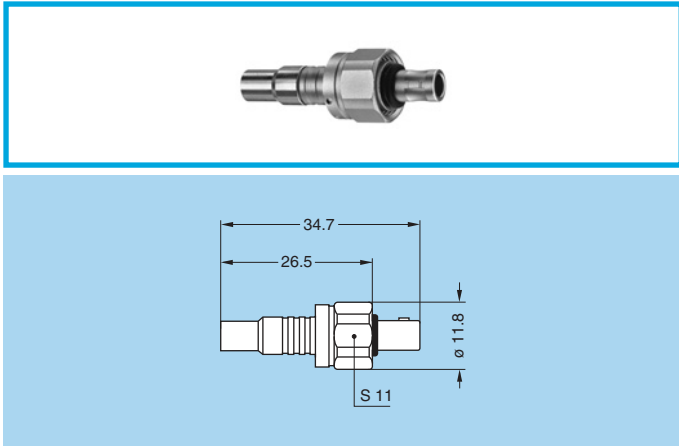

FVG Straight plug, key (G) for cable crimping

Part number	Cable ϕ (mm)	
	max.	
FVG.03.30●.CLAE44	4.3	
FVG.03.30●.SLAE44	4.3	
FVG.03.30●.CLAE52	5.1	
FVG.03.30●.SLAE52	5.1	

Note: ● = insert configuration (page 9)

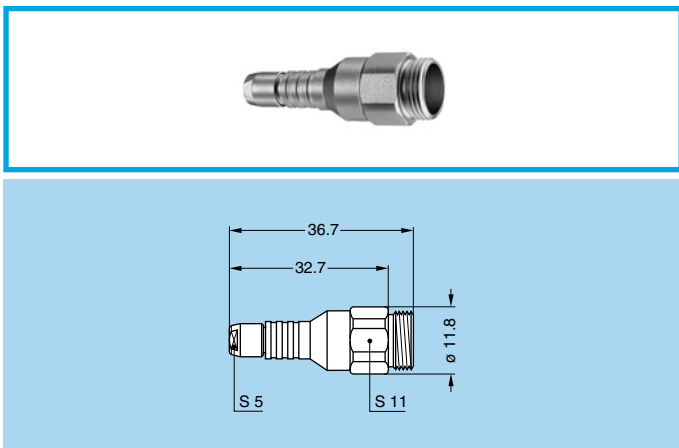

PVG Free socket, key (G) and cable collet

Part number	Cable ϕ (mm)	
	min.	max.
PVG.03.30●.CLLC27	2.4	2.6
PVG.03.30●.CLLC31	2.7	3.0

Note: ● = insert configuration (page 9)

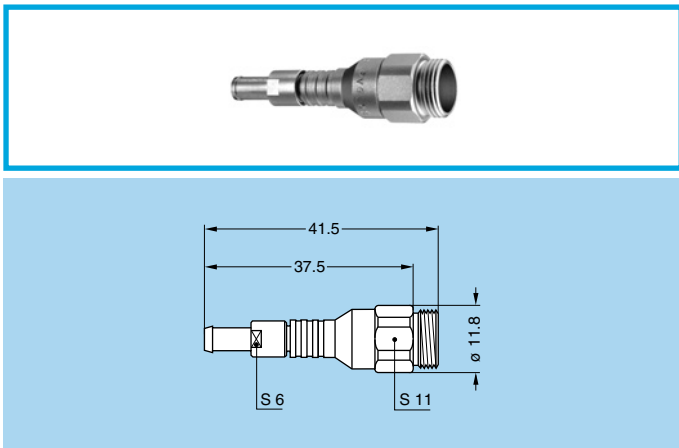

PVG Free socket, key (G), cable collet and nut for fitting a bend relief

Part number	Cable ϕ (mm)	
	min.	max.
PVG.03.30●.CLLC27Z	2.4	2.6
PVG.03.30●.CLLC31Z	2.7	3.0

Note: ● = insert configuration (page 9).
The bend relief must be ordered separately (page 10)

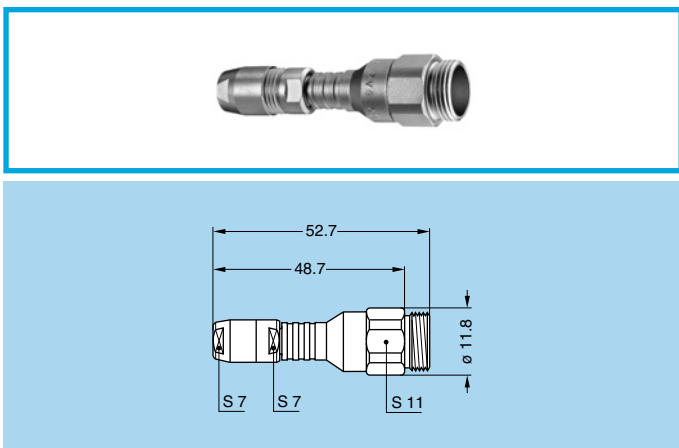

PVG Free socket, key (G) and oversize cable collet

Part number	Cable ϕ (mm)	
	min.	max.
PVG.03.30●.CLLK35	3.1	3.5
PVG.03.30●.CLLK40	3.6	4.0
PVG.03.30●.CLLK45	4.1	4.5
PVG.03.30●.CLLK50	4.6	5.0

Note: ● = insert configuration (page 9)
Correspond to K type of collet.
Also available with nut for fitting a bend relief.

Vacuumtight models (multipole type)

These sockets models allow the device on which they are fitted to reach a protection index of IP68 as per IEC 60529. They are fully compatible with plugs of the same series and are widely used for portable radios, military, laboratory equipment, aviation, etc.

These models are identified by a letter «P» or «S» at the last but one character of the reference. The Stycast® sealant can be used over a larger temperature range than the Araldite® sealant.

All these models are available in a watertight or vacuumtight version. Vacuumtight models are identified by an additional letter «V» at the end of the part number (certificate on request). Epoxy resin is used to seal these models.

Technical Characteristics

Mechanical and Climatical

Characteristics	Value	Standard
Endurance	> 1000 cycles	IEC 60512-5 test 9a
Humidity	up to 95% at 60° C	
Temperature range	-20° C, +100° C	
Salt spray corrosion test	> 144h	IEC 60512-6 test 11f

Characteristics	Value	Standard
Climatical category	20/80/21	IEC 60068-1
Leakage rate (He) ¹⁾	< 10 ⁻⁷ mbar.l.s ⁻¹	IEC 60512-7 test 14b
Max. operating pressure ²⁾	60 bars	IEC 60512-7 test 14d

Note: ¹⁾ only for vacuumtight models. ²⁾ this value corresponds to the maximum allowed pressure difference for the assembled socket.

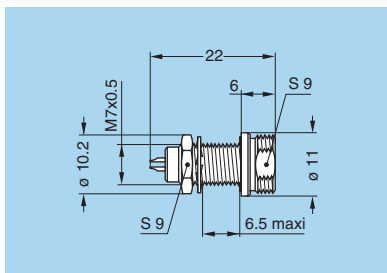
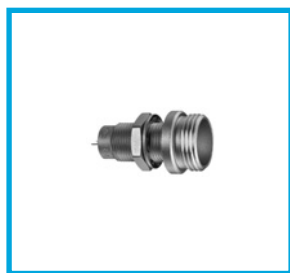

HVG Fixed socket, key (G) or key (B), round flange, nut fixing, vacuumtight

Part number	Sealing resin
HVG.03.30●.CLLPV	Araldite®
HVG.03.30●.SLLPV	Araldite®
HVG.03.30●.CLLSV	Stycast®
HVG.03.30●.SLLSV	Stycast®

Panel cut-out (page 11)
Note: ● = insert configuration (page 9)

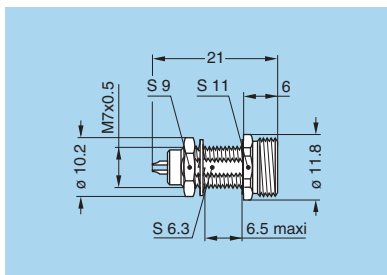

HWG Fixed socket, key (G), hexagonal flange, nut fixing, vacuumtight

Part number	Sealing resin
HWG.03.30●.CLLPV	Araldite®
HWG.03.30●.CLLSV	Stycast®

Panel cut-out (page 11)
Note: ● = insert configuration (page 9)

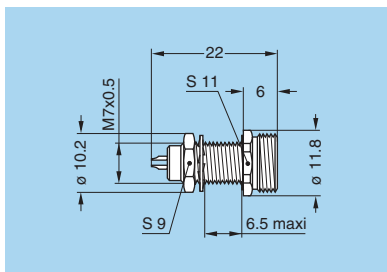
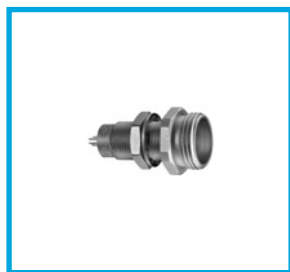

HRG Fixed socket, key (G), hexagonal flange, nut fixing, no flats on fixing thread, vacuumtight

Part number	Sealing resin
HRG.03.30●.CLLPV	Araldite®
HRG.03.30●.SLLPV	Araldite®
HRG.03.30●.CLLSV	Stycast®
HRG.03.30●.SLLSV	Stycast®

Panel cut-out (page 11)
Note: ● = insert configuration (page 9)

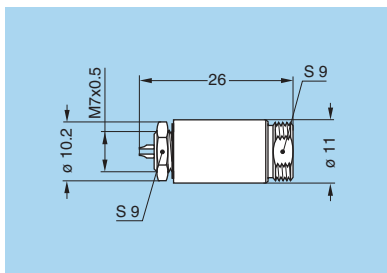

HTG Fixed socket, key (G), nut fixing, long shell

Part number	Sealing resin
HTG.03.30●.CLLSV	Stycast®

Panel cut-out (page 11)
Note: ● = insert configuration (page 9)



Models (coaxial type)

Technical Characteristics

Mechanical and Climatical

Characteristics	Value	Standard
Endurance	> 1000 cycles	IEC 60512-5 test 9a
Humidity	up to 95% at 60° C	
Temperature range	-20° C, +200° C	
Salt spray corrosion test	> 144 h	IEC 60512-6 test 11f
Protection index ²⁾	> IP68	IEC 60529
Resistance to hydrostatic pressure ²⁾	~ 60 bars ¹⁾	IEC 60512-7 test 14d
Climatical category	20/200/21	IEC 60068-1

Note:

¹⁾ in order to perform correctly and withstand the pressure, cable assembly shall be made according to instruction we recommend. See page 11.

²⁾ For mated plug and socket.

Electrical

Characteristics	Value	Standard	Section
Insulation resistance (new)	> 10 ¹² Ω	IEC 60512-2	test 3a
Insulation resistance ³⁾	> 10 ¹⁰ Ω	IEC 60512-2	test 3a
Shell electrical continuity	5.0 mΩ	IEC 60512-2	test 2f
Shielding efficiency	at 10 MHz	> 100 dB	IEC 60169-1-3
	at 1 GHz	> 80 dB	IEC 60169-1-3
Contact resist. ⁴⁾	∅ A = 0.5 mm	≤ 8.7 mΩ	IEC 60512-2 test 2a
Contact resist. ⁴⁾	∅ A = 0.7 mm	≤ 6.1 mΩ	IEC 60512-2 test 2a
Max. working frequency	500 MHz	For coaxial type	

Note:

³⁾ after humidity test: 21 days at 95% RH according to IEC 60068-2.

⁴⁾ after 5000 mating cycles and the salt spray test according to IEC 60512-6 test 11 f.

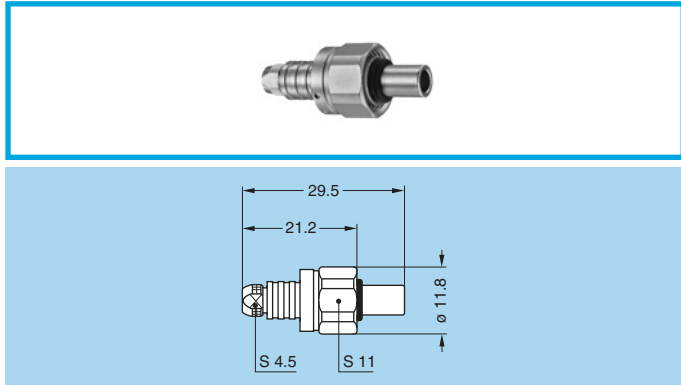

FVN Straight plug, cable collet

Part number	Cable group
FVN.03.250.CLAC27	4
FVN.03.250.SLAC27	4
FVN.03.250.CLAC31	3
FVN.03.250.SLAC31	3

Cable assembly (page 11)

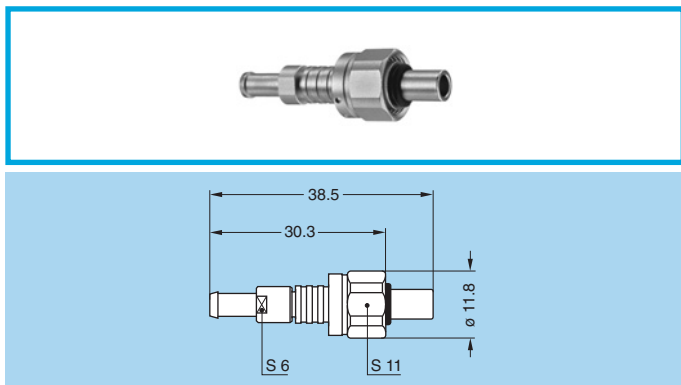

FVN Straight plug, cable collet and nut for fitting a bend relief

Part number	Cable group
FVN.03.250.CLAC27Z	4
FVN.03.250.SLAC27Z	4
FVN.03.250.CLAC31Z	3
FVN.03.250.SLAC31Z	3

Cable assembly (page 11)

Note: The bend relief must be ordered separately (page 10)

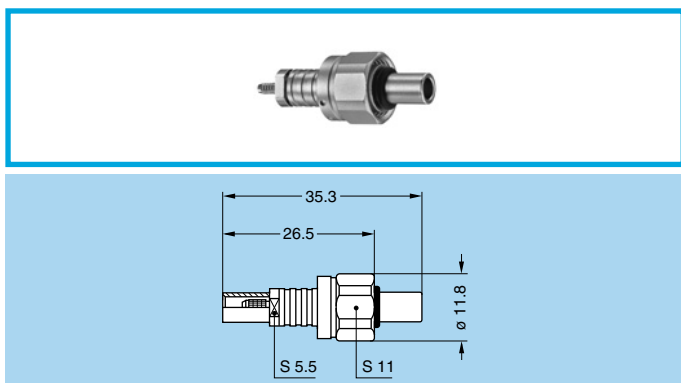

FVS Straight plug for cable crimping

Part number	Cable group
FVS.03.250.CLAE24	1
FVS.03.250.CLCE24	1
FVS.03.250.CLCE31	3-4

Cable assembly (page 11)

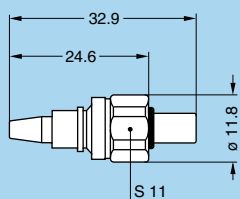

FVR Straight plug with brazing ferrule

Part number	Cable \varnothing (mm) max.
FVR.03.250.SLAV16B	1.55
FVR.03.250.SLAV20B	1.95

Cable assembly (page 11)

Note: The shell of the connector is in stainless steel AISI 316L.

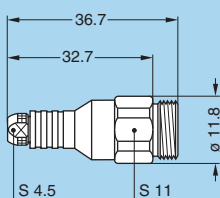

PVN Free socket and cable collet

Part number	Cable group
PVN.03.250.CLCC27	4
PVN.03.250.CLCC31	3

Cable assembly (page 11)

Note: Also available with nut for fitting a bend relief (page 10).

Vacuumtight models (coaxial type)

These sockets models allow the device on which they are fitted to reach a protection index of IP68 as per IEC 60529. They are fully compatible with plugs of the same series and are widely used for portable radios, military, laboratory equipment, aviation, etc.

These models are identified by a letter «P» or «S» at the last but one character of the reference. The Stycast® sealant can be used over a larger temperature range than the Araldite® sealant.

All these models are available in a watertight or vacuumtight version. Vacuumtight models are identified by an additional letter «V» at the end of the part number (certificate on request). Epoxy resin is used to seal these models.

Technical Characteristics

Mechanical and Climatical

Characteristics	Value	Standard
Endurance	> 1000 cycles	IEC 60512-5 test 9a
Humidity	up to 95% at 60° C	
Temperature range	-20° C, +100° C	
Salt spray corrosion test	> 144h	IEC 60512-6 test 11f

Characteristics	Value	Standard
Climatical category	20/80/21	IEC 60068-1
Leakage rate (He) ¹⁾	< 10 ⁻⁷ mbar.l.s ⁻¹	IEC 60512-7 test 14b
Max. operating pressure ²⁾	60 bars	IEC 60512-7 test 14d

Note: ¹⁾ only for vacuumtight models. ²⁾ this value corresponds to the maximum allowed pressure difference for the assembled socket.

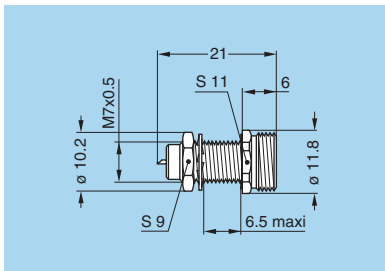

HVR Fixed socket, hexagonal flange, nut fixing, vacuumtight

Part number	Sealing resin
HVR.03.250.CLLPV	Araldite®
HVR.03.250.SLLPV	Araldite®
HVR.03.250.CLLSV	Stycast®
HVR.03.250.SLLSV	Stycast®

Panel cut-out (page 11)

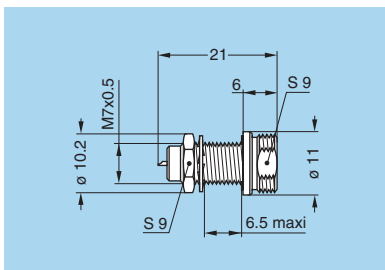

HVP Fixed socket, round flange, nut fixing, vacuumtight

Part number	Sealing resin
HVP.03.250.CLLPV	Araldite®
HVP.03.250.CLLSV	Stycast®

Panel cut-out (page 11)

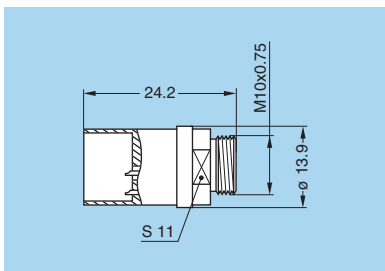

HVL Free socket, for device overmolding

Part number
HVL.03.250.NLL

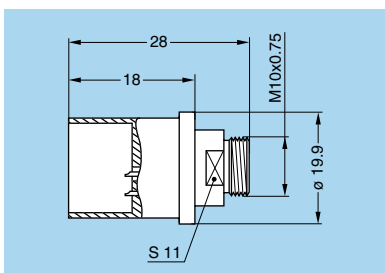
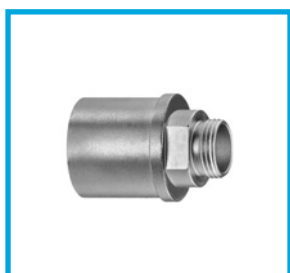

HWW Free socket, for device overmolding, large shell

Part number
HWW.03.250.NLL

Note: Vacuumtightness is achieved after customer overmolding.

Alignment Key

Alignment Key and Polarized Keying System for Multipole Types

03 series connector model part numbers are composed of three letters. The LAST LETTER indicates the key position and the contact type (male or female).

Front view of a socket 	Model	Nb of keys	Angles	Series	Contact type	
				03	Plug	Socket
	G	1		0°	male	female
B	2	α	60°	male	female	

Insert configuration

Coaxial, multipole

		Male solder contacts	Female solder contacts	Reference	Number of contacts	ϕ A (mm)	Cable group	AWG max.	Impedance (Ω)	Test voltage (kV rms) ¹⁾ Contact-contact	Test voltage (kV rms) ¹⁾ Contact-shell	Rated current (A) ¹⁾
03	Coaxial			250	1	0.7	1-3-4	-	50	2.1	2.10	4.0
	Multipole			302	2	0.5	-	30	-	1.0	0.95	5.0
				303	3	0.5	-	30	-	0.8	0.95	3.0
				304	4	0.5	-	30	-	0.8	0.95	2.0

Note: ¹⁾ Test voltage measured according to IEC 60512-2 test 4a standard.

Housings

Ref.	Outer shell and collet nut		Latch sleeve + earthing crown		Other metallic components		Remarks	Note
	Material	Surf. treatment	Material	Surf. treatment	Material	Surf. treatment		
C	Brass	chrome	brass/bronze	nickel	brass	nickel	For multipole and coaxial	●
S	Stainless steel	-	brass/bronze	nickel	brass	nickel	For multipole and coaxial	○

Note: detailed characteristics of these materials and treatments are presented in the Unipole-Multipole catalogue.

- First choice alternative
- Special order alternative

Contacts

Ref.	Contact type	Remarks
A	Male solder	For multipole and coaxial
C	Male crimp	For coaxial
L	Female solder	For multipole or coaxial type sockets

Variant

Bend relief for models with collet

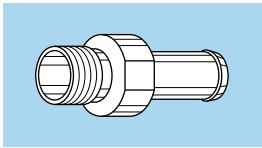

Need to be ordered

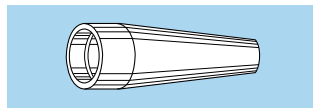

03	Ref.	Collet		Need to be ordered separately	Dim. (mm)	
		Type	Code		Cable ø	max.
Z	Z	C	27	GMB.00.025.DG	2.8	2.5
		C	31	GMB.00.028.DG	3.1	2.8
		C	27	GMD.00.025.DG	2.8	2.5
		C	31	GMD.00.028.DG	3.1	2.8
Z	Z	K	35	GMA.0B.030.DG	3.4	3.0
		K	40	GMA.0B.035.DG	3.9	3.5
		K	45	GMA.0B.040.DG	4.4	4.0
		K	50	GMA.0B.045.DG	5.2	4.5

Note: The «GMD» are thin bend reliefs (for very flexible cables).
The last letter «G» of the part number indicates the grey colour of the bend relief.

Accessories and Tooling

For accessories and tooling, please contact us.

Panel cut-outs

Panel Cut-outs

HWG

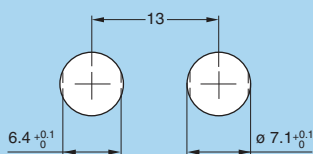

HRG, HTG, HVG,
HVP, HVR

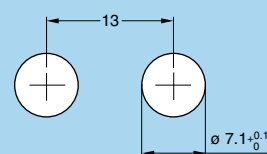

Mounting nuts torque

Component	Torque (Nm)
Retaining nut	0.25
Hexagonal nut	2.00
Coupling nut	2.00

1N = 0.102 kg

Cable assembly

Assembly instructions

In order to ensure the sealing of plugs and sockets on the cable side, it is imperatively necessary to complete their assembly by realizing it with an adapted technique.

We recommend the fitting of an heatshrink boot with inner melting coating of type ATUM (manufactured by the RAY-CHEM company) or similar.

This heatshrink boot is not provided with the connector. Please consult us.

Cable stripping lengths

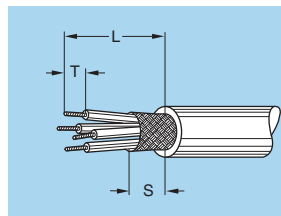

Connector		ø contact A (mm)	Cable stripping lengths (mm)		
Series	Type		L	S	T
03	250	0.7	6	2.5	3
	302/303/304	0.5	6	2.5	3
	302/303/304 ¹⁾	0.5	13.5	-	2.5

Note:
the tolerances on these dimensions are:
L: ± 0.5 mm; S: ± 0.5 mm; T: ± 0.2 mm.
¹⁾ for FVG model with cable crimping.

Recommended coaxial cables

Recommended cables for coaxial types

Cable group	Standard			Reference	Imp. (Ω)
	MIL-C-17	IEC 96-2	CCTU 10-01A		
3	RG.174 A/U	50.2.1	KX 3A	CCX.50.RG1.74AU27N	50 ± 2 Ω
			KX 38	CCX.50.RG1.74U25N	50 ± 2 Ω
1	RG.178 B/U	50.1.1	KX 21A	CCX.50.RG1.78BU18M	50 ± 2 Ω
4	RG.188 A/U	50.2.3		CCX.50.RG1.88AU24B	50 ± 2 Ω
1	RG.196 A/U	50.1.2		CCX.50.RG1.96AU20B	50 ± 2 Ω
4	RG.316 /U	50.2.2	KX 22A	CCX.50.RG3.16BU26M	50 ± 2 Ω

Product safety notice

PLEASE READ AND FOLLOW ALL INSTRUCTIONS CAREFULLY AND CONSULT ALL RELEVANT NATIONAL AND INTERNATIONAL SAFETY REGULATIONS FOR YOUR APPLICATION. IMPROPER HANDLING, CABLE ASSEMBLY, OR WRONG USE OF CONNECTORS CAN RESULT IN HAZARDOUS SITUATIONS.

1. SHOCK AND FIRE HAZARD

Incorrect wiring, the use of damaged components, presence of foreign objects (such as metal debris), and / or residue (such as cleaning fluids), can result in short circuits, overheating, and / or risk of electric shock. Mated components should never be disconnected while live as this may result in an exposed electric arc and local overheating, resulting in possible damage to components.

2. HANDLING

Connectors and their components should be visually inspected for damage prior to installation and assembly. Suspect components should be rejected or returned to the factory for verification. Connector assembly and installation should only be carried out by properly trained personnel. Proper tools must be used during installation and / or assembly in order to obtain safe and reliable performance.

3. USE

Connectors with exposed contacts should never be live (or on the current supply side of a circuit). Under general conditions voltages above 30 VAC and 42 VDC are considered hazardous and proper measures should be taken to eliminate all risk of transmission of such voltages to any exposed metal part of the connector.

4. TEST AND OPERATING VOLTAGES

The maximum admissible operating voltage depends upon the national or international standards in force for the application in question. Air and creepage distances impact the operating voltage; reference values are indicated in the catalog however these may be influenced by PC board design and / or wiring harnesses. The test voltage indicated in the catalog is 75% of the mean breakdown voltage; the test is applied at 500 V/s and the test duration is 1 minute.

5. CE MARKING

CE marking  means that the appliance or equipment bearing it complies with the protection requirements of one or several European safety directives.

CE marking  applies to complete products or equipment, **but not to electromechanical components, such as connectors.**

6. PRODUCT IMPROVEMENTS

The LEMO Group reserves the right to modify and improve to our products or specifications without providing prior notification.

LEMO complete product range

	B	S	K	E	F	00	01	0A	3T	4A	4M	3K.93C	1D	Y	05	5G	2G	2C	L	H	R	N	03	V	W	U	F	P	D	K/S	01	DIN		
Unipole		•		•																														
Multipole	•	•	•	•													•	•	•															
Coaxial 50 Ω																																		
Coaxial 75 Ω																																		
Multi Coaxial																																		
Mixed Coax + LV																																		
Triaxial 50 Ω																																		
Triaxial 75 Ω																																		
Mixed Triax + LV																																		
Quadrax																																		
High Voltage																																		
Multi High Voltage																																		
Mixed HV + LV																																		
Fibre Optic																																		
Multi Fibre Optic																																		
Mixed FO + LV																																		
Thermocouple																																		
Fluidic																																		
Multi Fluidic																																		
Mixed Fluidic + LV																																		

Most frequently used in darker colour

• included in this catalogue

B Series <small>Keyed</small>	S Series	K Series <small>Keyed</small>	E Series	F Series <small>Keyed</small>	00 Series	01 Series
0A Series	3T Series	4A Series	4M Series <small>Keyed</small>	3K.93C Series <small>Keyed</small>	1D Series	Y Series
05 Series	5G Series <small>Keyed</small>	2G Series <small>Keyed</small>	2C Series	L Series <small>Keyed</small>	H Series	R Series <small>Keyed</small>
N Series <small>Keyed</small>	03 Series <small>Keyed</small>	V Series	W Series <small>Keyed</small>	U Series <small>Keyed</small>	Cable assembly	K/S Series <small>Keyed</small>
REDEL F Series	REDEL P Series <small>Keyed</small>	REDEL D Series	01 Series <small>Keyed</small>	VAA Series	SAA Series	TAA Series

No reproduction or use without express permission of editorial or pictorial content, in any manner.
LEMO SA reserves the right to modify and improve specifications, at all times, without any notification.

LEMO HEADQUARTERS

SWITZERLAND

LEMO SA

Chemin des Champs-Courbes 28 - P.O. Box 194 - CH-1024 Ecublens
Tel. (+41 21) 695 16 00 - Fax (+41 21) 695 16 02 - e-mail: info@lemo.com

LEMO SUBSIDIARIES

AUSTRIA

LEMO Elektronik GesmbH

Lemböckgasse 49/E6-3
1230 Wien
Tel: (+43 1) 914 23 20 0
Fax: (+43 1) 914 23 20 11
sales@lemo.at

CHINA

LEMO Trading (Shanghai) Co., Ltd

LEMO Electronics (Shanghai) Co., Ltd

5th Floor, Block 6, City of ELITE,
1000 Jinhai Road, Pudong
Shanghai, China 201206
Tel: (+86 21) 5899 7721
Fax: (+86 21) 5899 7727
cn.sales@lemo.com

DENMARK

LEMO Denmark A/S

Gammel Mosevej 46
2820 Gentofte
Tel: (+45) 45 20 44 00
Fax: (+45) 45 20 44 01
info-dk@lemo.com

FRANCE

LEMO France Sàrl

24/28 Avenue Graham Bell
Bâtiment Balthus 4
Bussy Saint Georges
77607 Marne la Vallée Cedex 3
Tel: (+33 1) 60 94 60 94
Fax: (+33 1) 60 94 60 90
info-fr@lemo.com

GERMANY

LEMO Elektronik GmbH

Hanns-Schwindt-Str. 6
81829 München
Tel: (+49 89) 42 77 03
Fax: (+49 89) 420 21 92
info@lemo.de

HONG KONG

LEMO Hong Kong Ltd

Unit 1207, 12/F, Corporation Square,
8 Lam Lok Street, Kowloon Bay,
Kowloon - Hong Kong
Tel: (+852) 2174 0468
Fax: (+852) 2174 0492
hk.sales@lemo.com

HUNGARY

REDEL Elektronika Kft

Nagysándor József u. 6-12
1201 Budapest
Tel: (+36 1) 421 47 10
Fax: (+36 1) 421 47 57
redelemo@lemo.hu

ITALY

LEMO Italia srl

Viale Lunigiana 25
20125 Milano
Tel: (+39 02) 66 71 10 46
Fax: (+39 02) 66 71 10 66
sales.it@lemo.com

JAPAN

LEMO Japan Ltd

4-10-3, Takaido Higashi,
Suginami-ku, Tokyo, 168-0072
Tel: (+81 3) 53 44 39 33
Fax: (+81 3) 53 44 39 35
lemoinfo@lemo.co.jp

NETHERLANDS / BELGIUM

LEMO Connectors Benelux

De Trompet 2108
1967 DC Heemskerk
Tel. (+31) 251 25 78 20
Fax (+31) 251 25 78 21
info@lemo.nl

NORWAY / ICELAND

LEMO Norway A/S

Stanseveien 6B
0975 Oslo
Tel: (+47) 22 91 70 40
Fax: (+47) 22 91 70 41
info-no@lemo.com

SINGAPORE

LEMO Asia Pte Ltd

4 Leng Kee Road,
#06-09 SiS Building
Singapore 159088
Tel: (+65) 6476 0672
Fax: (+65) 6474 0672
sg.sales@lemo.com

SPAIN / PORTUGAL

IBERLEMO S.A.

Brasil, 45, 08402 Granollers
Barcelona
Tel: (+34 93) 860 44 20
Fax: (+34 93) 879 10 77
info-es@lemo.com

Madrid Office
Antonio López, 96, 28019 Madrid
Tel: (+34 91) 469 99 19
Fax: (+34 91) 469 99 59

SWEDEN / FINLAND

LEMO Nordic AB

Mariehällsvägen 39A
168 65 Bromma
Tel: (+46 8) 635 60 60
Fax: (+46 8) 635 60 61
info-se@lemo.com

SWITZERLAND

LEMO Verkauf AG

Grundstrasse 22 B
6343 Rotkreuz
Tel: (+41 41) 790 49 40
Fax: (+41 41) 790 49 43
ch.sales@lemo.com

UNITED KINGDOM

LEMO UK Ltd

12-20 North Street
Worthing
West Sussex, BN11 1DU
Tel: (+44 1903) 23 45 43
Fax: (+44 1903) 20 62 31
lemouk@lemo.com

USA

LEMO USA Inc

P.O. Box 2408
Rohnert Park, CA 94927-2408
Tel: (+1 707) 578 88 11
(+1 800) 444 53 66
Fax: (+1 707) 578 08 69
info@lemousa.com

LEMO DISTRIBUTORS

AUSTRALIA, BRAZIL, CANADA, CZECH REPUBLIC, GREECE, INDIA, ISRAEL,
NEW ZEALAND, PAKISTAN, POLAND, RUSSIA, SOUTH AFRICA, SOUTH KOREA,
TAIWAN, TURKEY, UKRAINE

www.lemo.com