

NOTES:

1. MATERIAL:  
-BODY - HIGH COPPER CONTENT ALLOY, TIN PLATED  
-HARDWARE - REFERENCE CHART
2. PARTS ARE cULus LISTED TO UL467/CSA 22.2 NO 41.
3. CONNECTORS ACCOMMODATE EITHER ONE OR TWO COPPER CONDUCTORS IN THE RANGE SPECIFIED.
4. TO PREVENT BOLT ROTATION, DRIVE RIBBED SECTION OF BOLT INTO 0.44 [11.2] DIA HOLE.
5. DIMENSIONS IN PARENTHESIS ARE MILLIMETERS
6. PACKAGE QUANTITIES"  
L = 50

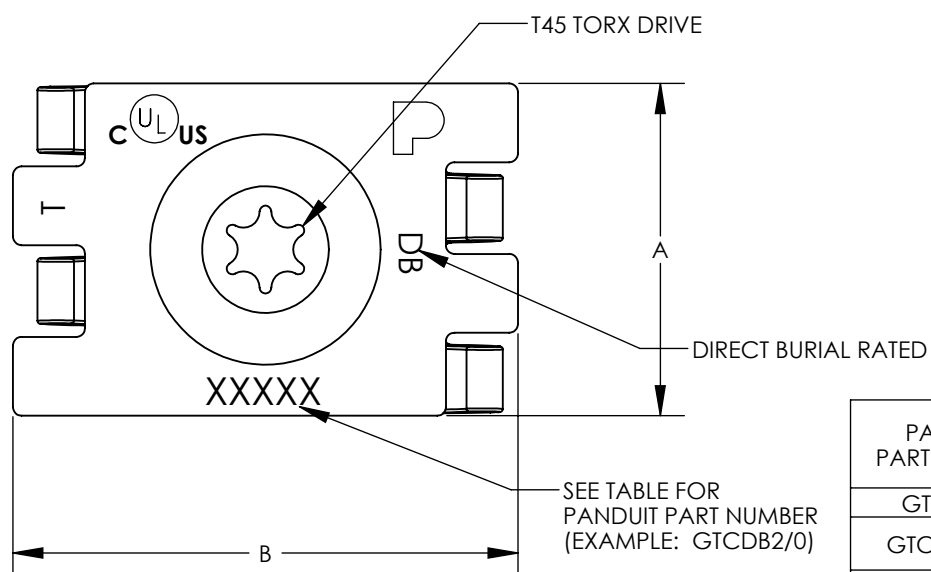

PANDUIT PART NUMBER	COPPER CONDUCTOR RANGE	DIRECT BURIAL RATED	HARDWARE		ACCOMODATES TRAY WALL THICKNESS	DIMENSIONS IN [mm]		
			BOLT	NUT/WASHERS		A	B	C
GTC1/0-L	6 SOL - 1/0 STR	NO	ZINC PLATED STEEL	ZINC PLATED STEEL	STEEL/ALUMINUM .062 [1.57] TO 0.125 [3.18]	1.15 [29.2]	1.49 [37.8]	2.0 [50.8]
GTCDB1/0-L		YES	ZINC/NICKEL PLATED STAINLESS STEEL	STAINLESS STEEL				
GTC2/0-L	2 SOL - 2/0 STR	NO	ZINC PLATED STEEL	ZINC PLATED STEEL	STEEL/ALUMINUM .062 [1.57] TO 0.125 [3.18]		2.04 [51.8]	
GTCDB2/0-L		YES	ZINC/NICKEL PLATED STAINLESS STEEL	STAINLESS STEEL				
GTC250-L	2/0 STR - 250 kcmil 4/0 SOL	NO	ZINC PLATED STEEL	ZINC PLATED STEEL	STEEL 0.96 [2.44] TO 0.125 [3.18] ALUMINUM 0.062 [1.57] TO 0.125 [3.18]			
GTCDB250-L		YES	ZINC/NICKEL PLATED STAINLESS STEEL	STAINLESS STEEL				

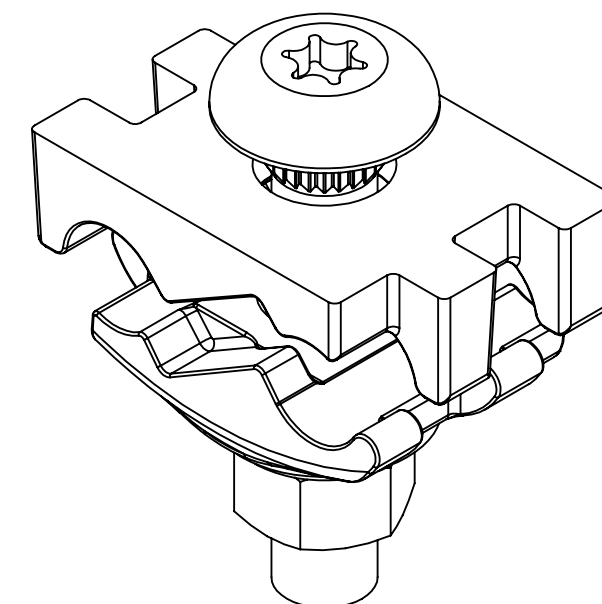
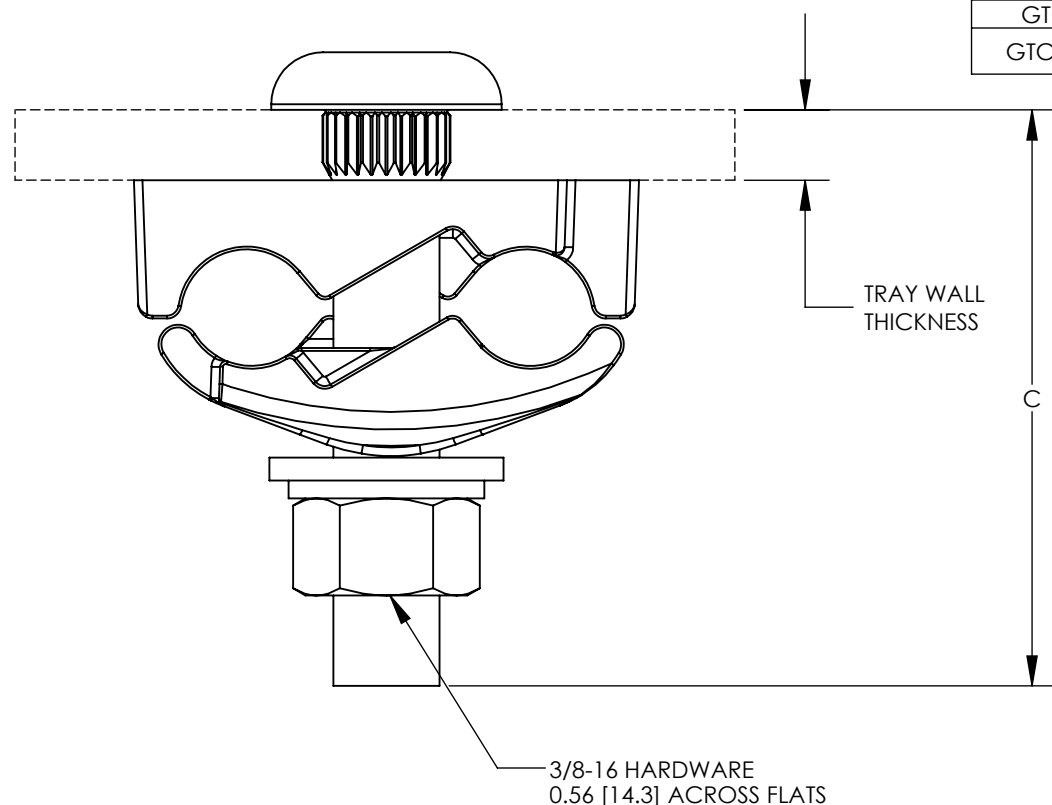

REV	DATE	BY	CHK	APR	DESCRIPTION	ECN
02	5/18	JHNU	BKR	RGB	ADDED TORX DRIVE NOTE	13J051AJ-DC
01	3/18	JHNU	BKR	RGB	REVISED HARDWARE	
00	5/17	JHNU	BKR	RGB	DRAWING RELEASED	

TITLE		<b>CABLE TRAY CLAMPS</b>		
ITEM REVISION NAME		13J051AJ/02		
DATASET FILE NAME		13J051AJ-DC/02.SLDDRW		
UNLESS OTHERWISE SPECIFIED, DIMENSIONAL TOLERANCES ARE: IN [mm]		THIRD ANGLE PROJECTION		
.X ±				
.XX ±		ANGLES ±		
DRAWN BY	DATE	CHK	SCALE	DRAWING NUMBER
JHNU	5/17	BKR	N/A	13J051AJ-DC
SHEET 1 OF 1				SIZE
				B