



actual size

# Oscillator JT21CT · TCXO

- TCXO with HCMOS output, 2.0 x 1.6 mm
- wide operating temperature range up to +105 °C
- excellent phase noise
- with standby function, low standby current
- ceramic/metal package



RoHS compliant



Pb free



REACH compliant



Conflict mineral free

GENERAL DATA		
TYPE	JT21CT TCXO	
frequency range	13.0 ~ 52.0 MHz	
frequency tolerance / stability	at +25 °C	± 2.0 ppm (incl. 2x reflow)
	temperature	±2.0 ppm ~ ±10.0 ppm (see table 1)
	aging first year	± 1.0 ppm (at +25 °C)
	supply voltage	± 0.2 ppm (at V <sub>DC</sub> ±5%)
	load change	± 0.2 ppm
current consumption	5.0 mA (< 26.0 MHz) / 7.0 mA (< 52.0 MHz)	
supply voltage V <sub>DC</sub>	1.8V / 2.5V / 2.8V / 3.0V / 3.3V (±5%)	
temperature	operating	-40 °C ~ +85 °C (temperature code K) -40 °C ~ +105 °C (temperature code P)
	storage	-40 °C ~ +105 °C
output	rise & fall time	5.0 ns max. (10% ↔ 90% of V <sub>DC</sub> )
	load max.	15 pF
	current max.	0.4 mA
	low level max.	0.2 x V <sub>DC</sub>
	high level min.	0.8 x V <sub>DC</sub>
symmetry at 0.5 x V <sub>DC</sub>	45 % ~ 55 % max.	
start-up time max.	3 ms	
output enable time max.	3 ms	
output disable time max.	150 ns	
standby current max.	10 µA	
phase jitter	12 kHz ~ 20.0 MHz	-300 fs RMS typ. / 500 fs RMS max.

TABLE 1: FREQUENCY STABILITY CODE					
frequency stability		B	A	Y	X
temperature code		± 2.0 ppm	± 2.5 ppm	± 5.0 ppm	± 10.0 ppm
-40 °C ~ +85 °C	K	Δ	○	○	
-40 °C ~ +105 °C	P		○	○	○

○ on request Δ case-by-case, ask if available

ENABLE / DISABLE FUNCTION	
PIN #1 (E/D CONTROL)	PIN #3 (OUTPUT)
high "1" (V <sub>IH</sub> ≥ 0.8 V <sub>DC</sub> )	active (see note)
low "0" (V <sub>IL</sub> ≤ 0.2 V <sub>DC</sub> )	high impedance
stop function: - oscillator stops - output high impedance	

NOTE
- e/d control pin has weak internal pull-up, use external pull-up to ensure TCXO activation
- for best supply noise rejection, connect a capacitor closely to the supply voltage pins
- a separate voltage supply rail ensures best phase noise

PHASE NOISE AT FO 40.0 MHz	
at 100 Hz	-115 dBc/Hz typ.
at 1 kHz	-135 dBc/Hz typ.
at 10 kHz	-150 dBc/Hz typ.

DIMENSIONS			
<p>top view</p>	<p>side view</p>	<p>bottom view</p>	<p>pad layout</p>
<p>TCXO JT21CT # 1: e/d # 2: GND # 3: output # 4: V<sub>DC</sub></p>			<p>pin connection</p>
in mm			

ORDER INFORMATION						
0	frequency	type	frequency stability code	operating temp. code	supply voltage	
Oscillator	13.0 ~ 52.0 MHz	JT21CT = TCXO	B = ±2.0 ppm A = ±2.5 ppm Y = ±5.0 ppm X = ±10.0 ppm	K = -40 °C ~ +85 °C P = -40 °C ~ +105 °C	1.8 = 1.8 V 2.5 = 2.5 V 3.0 = 3.0 V 3.3 = 3.3 V	
<b>Example: 0 40.0-JT21CT-Y-P-3.3-LF</b> (Suffix LF = RoHS compliant / Pb free)						

# Oscillator JT21CT · Wide Temperature Range TCXO

## TAPING SPECIFICATION

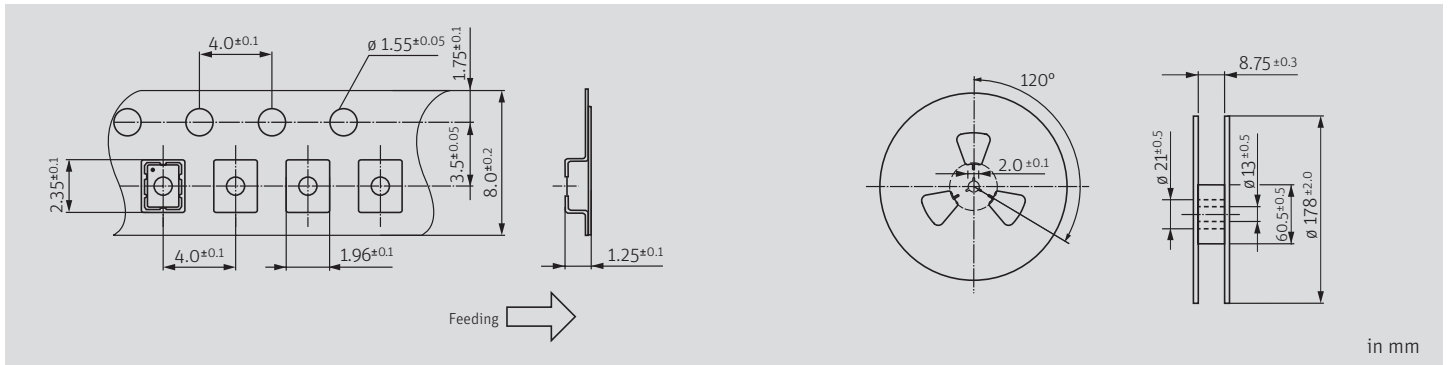

## REFLOW SOLDERING PROFILE

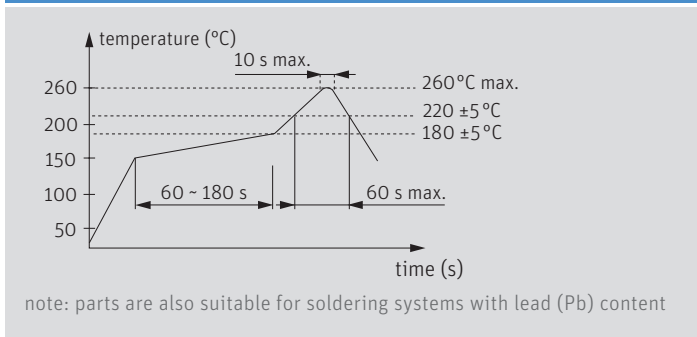

## MARKING

### frequency

### company code / stability code / date code

date code: A ~ M: Jan. - Dec.

2: 2022   3: 2023   4: 2024   5: 2025   6: 2026   7: 2027

Jan.	Febr.	Mar.	Apr.	May	June
A	B	C	D	E	F
July	Aug.	Sept.	Oct.	Nov.	Dec.
G	H	J	K	L	M

## PACKAGING NOTE

- standard packaging unit is 500 pieces per reel
- customized quantities on request