

REF. -50 OPT. SCREW  
(WHERE APPLICABLE)

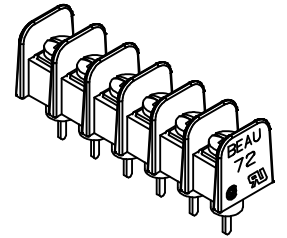

AUX. VIEW  
SCALE 1:1  
(6 CIRCUIT SHOWN)

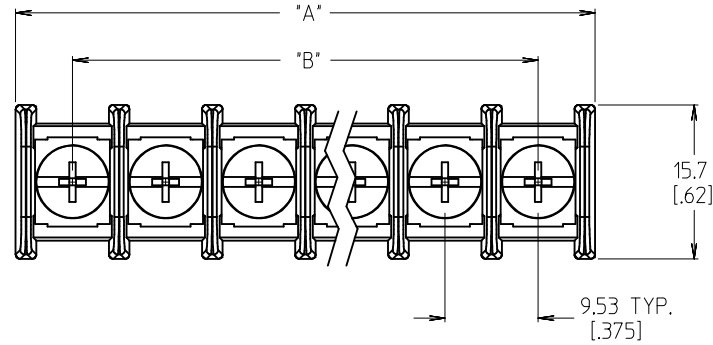
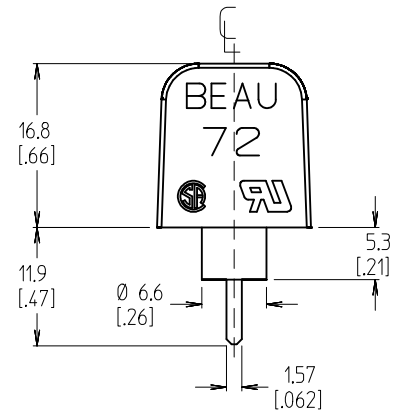
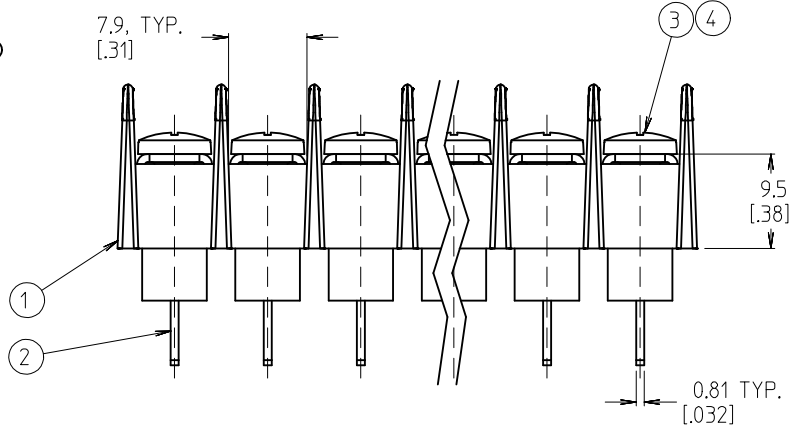
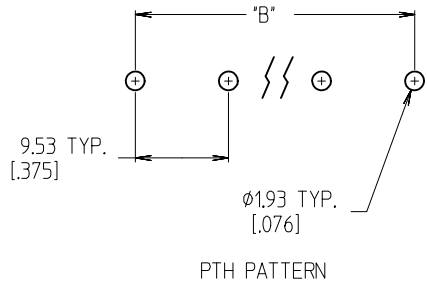

NOTES:

1. MATERIAL: SEE TABLE
2. FINISH: SEE TABLE
3. INCH DIMS ARE SHOWN IN BRACKETS [XXX].
4. "XX" REFERS TO THE QUANTITY OF CIRCUITS.
5. ALL COMPONENTS ARE ROHS COMPLIANT.

5	XX	SCREW&WASHER, #6-32 PH/SL (-50 OPT)	STEEL	ZN, CLEAR CHROMATE
4	XX	SCREW, #6-32 PH/SL (-49 OPT)	BRASS	NICKEL PLATE
3	XX	SCREW, #6-32 PH/SL (STANDARD)	STEEL	ZN, CLEAR CHROMATE
2	XX	TERMINAL, WIRE WRAP	BRASS	TIN PLATE
1	1	INSULATOR	PBT, GF	BLACK
ITEM	QTY.	DESCRIPTION	MATERIAL	FINISH

INITIAL RELEASE EC NO: ETC2006-0481 DRAWN BY: C. YORK 2006/06/05 CHKD: RDEROSS 2006/06/07 APPR: RDEROSS 2006/06/07	DESCRIPTION REV A	QUALITY SYMBOLS	GENERAL TOLERANCES (UNLESS SPECIFIED)	DIMENSION STYLE	SCALE	DESIGN UNITS	THIRD ANGLE PROJECTION		
		▼=0 ▽=0	mm INCH 4 PLACES ± --- ± --- 3 PLACES ± --- ± .005 2 PLACES ± 0.13 ± .01 1 PLACE ± 0.3 ± --- ANGULAR ± 2 °	MM/IN	2:1	INCH	C. YORK 2006/06/02 R. DEROSS 2006/06/02 R. DEROSS 2006/06/02	TITLE 9.53 [0.375]" SR BTS, PC INSUL ASSY, NO MTG.	
		DRAFT WHERE APPLICABLE MUST REMAIN WITHIN DIMENSIONS			MATERIAL NO.	DOCUMENT NO.	MOLEX INCORPORATED		SHEET NO.
					SEE SHT. 2	SD-38720-009			1 OF 2
THIS DRAWING CONTAINS INFORMATION THAT IS PROPRIETARY TO MOLEX INCORPORATED AND SHOULD NOT BE USED WITHOUT WRITTEN PERMISSION									

# OF CIRCUITS "XX"	DIM. "A"		DIM. "B"		ASSEMBLY MATERIAL NO. (-C OPT)	ASSEMBLY MATERIAL NO. (-C-49 OPT)	ASSEMBLY MATERIAL NO. (-C-50 OPT)
	mm	in	mm	in			
02	21.1	0.83	9.53	0.375	387204802	387205102	387205402
03	30.6	1.21	19.05	0.750	387204803	387205103	387205403
04	40.1	1.58	28.58	1.125	387204804	387205104	387205404
05	49.7	1.96	38.10	1.500	387204805	387205105	387205405
06	59.2	2.33	47.63	1.875	387204806	387205106	387205406
07	68.7	2.71	57.15	2.250	387204807	387205107	387205407
08	78.2	3.08	66.68	2.625	387204808	387205108	387205408
09	87.8	3.46	76.20	3.000	387204809	387205109	387205409
10	97.3	3.83	85.73	3.375	387204810	387205110	387205410
11	106.8	4.21	95.25	3.750	387204811	387205111	387205411
12	116.3	4.58	104.78	4.125	387204812	387205112	387205412
13	125.9	4.96	114.30	4.500	387204813	387205113	387205413
14	135.4	5.33	123.83	4.875	387204814	387205114	387205414
15	144.9	5.71	133.35	5.250	387204815	387205115	387205415
16	154.4	6.08	142.88	5.625	387204816	387205116	387205416
17	164.0	6.46	152.40	6.000	387204817	387205117	387205417
18	173.5	6.83	161.93	6.375	387204818	387205118	387205418
19	183.0	7.21	171.45	6.750	387204819	387205119	387205419
20	192.5	7.58	180.98	7.125	387204820	387205120	387205420
21	202.1	7.96	190.50	7.500	387204821	387205121	387205421
22	211.6	8.33	200.03	7.875	387204822	387205122	387205422
23	221.1	8.71	209.55	8.250	387204823	387205123	387205423
24	230.6	9.08	219.08	8.625	387204824	387205124	387205424
25	240.2	9.46	228.60	9.000	387204825	387205125	387205425
26	249.7	9.83	238.13	9.375	387204826	387205126	387205426

SEE SHEET 1 EC NO: ETC2006-0481 DRAWN BY: C. YORK CHKD: RDEROSS APPR: RDEROSS A	2006/06/05 2006/06/07 2006/06/07	DESCRIPTION REV	QUALITY SYMBOLS	GENERAL TOLERANCES (UNLESS SPECIFIED)	DIMENSION STYLE	SCALE	DESIGN UNITS	THIRD ANGLE PROJECTION
			$\nabla=0$ $\nabla=0$	mm INCH	MM/IN	2:1	INCH	9.53 [.375"] SR BTS, PC INSUL ASSY, NO MTG.
			4 PLACES $\pm$ --- $\pm$ ---	mm INCH	DRAWN BY DATE	MOLEX INCORPORATED DOCUMENT NO. SD-38720-009 SHEET NO. 2 OF 2		
			3 PLACES $\pm$ --- $\pm$ .005	mm INCH	C. YORK 2006/06/02			
2 PLACES $\pm$ 0.13 $\pm$ .01	mm INCH	CHECKED BY DATE						
1 PLACE $\pm$ 0.3 $\pm$ ---	mm INCH	R. DEROSS 2006/06/02						
			ANGULAR $\pm$ 2 °					
			DRAFT WHERE APPLICABLE MUST REMAIN WITHIN DIMENSIONS		SEE CHART			

	NUMBER OF CIRCUITS "XX"	DIM. A		DIM. B	
		IN	MM	IN	MM
02	.83	21.1	.375	9.53	
03	1.21	30.7	.750	19.05	
04	1.58	40.1	1.125	28.58	
05	1.96	49.8	1.500	38.10	
06	2.33	59.2	1.875	47.63	
07	2.71	68.8	2.250	57.15	
08	3.08	78.2	2.625	66.68	
09	3.46	87.8	3.000	76.20	
10	3.83	97.3	3.375	85.73	
11	4.21	106.9	3.750	95.25	
12	4.58	116.3	4.125	104.78	
13	4.96	126.0	4.500	114.30	
14	5.33	135.4	4.875	123.83	
15	5.71	145.0	5.250	133.35	
16	6.08	154.4	5.625	142.88	
17	6.46	164.0	6.000	152.40	
18	6.84	173.7	6.375	161.93	
19	7.21	183.1	6.750	171.45	
20	7.58	192.5	7.125	180.98	
21	7.96	202.2	7.500	190.50	
22	8.33	211.6	7.875	200.03	
23	8.71	221.2	8.250	209.55	
24	9.08	230.6	8.625	219.08	
25	9.46	240.3	9.000	228.60	
26	9.83	250.0	9.375	238.13	

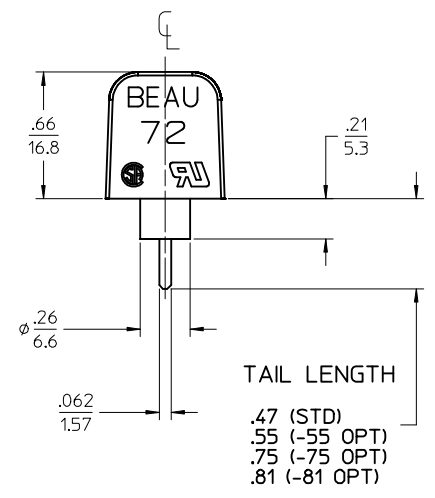
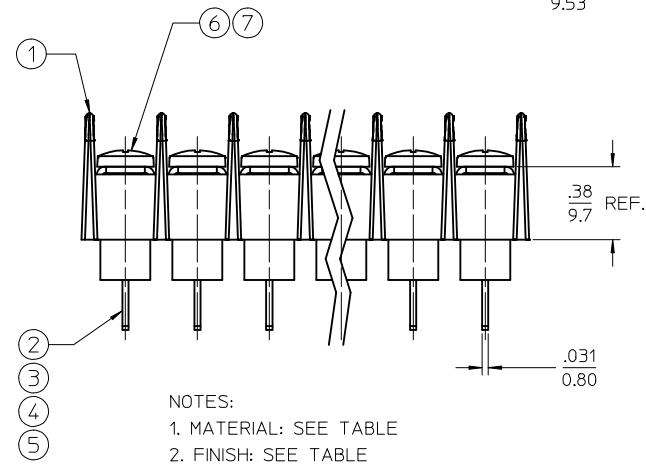
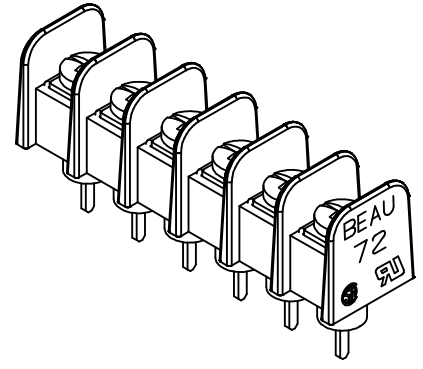
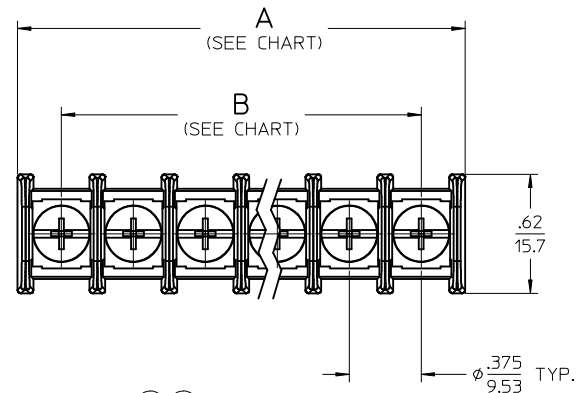
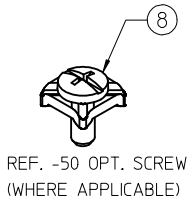

**ENGINEERING NUMBER LEGEND (OLD MATERIAL NO.)**

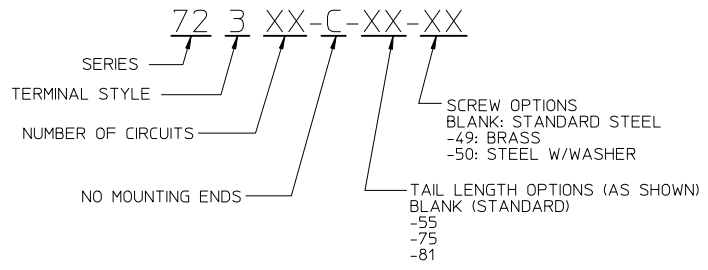

- NOTES:**
1. MATERIAL: SEE TABLE
  2. FINISH: SEE TABLE
  3. ELECTRICAL SPECS:  
MAX VOLTAGE: 300V (BINDING HD, 14 AWG)  
MAX CURRENT: 15A  
  
MAX VOLTAGE: 300V (-50 OPT, 12 AWG)  
MAX CURRENT: 25A
  4. REFER TO SD-38120-001 FOR IMPRINT OPTION 10A & 11A
  5. PRODUCT SPEC: PS-38710-001
  6. SCREW TIGHTENING TORQUE: 12 IN LBS. (MAX)
  7. WIRE STRIP LENGTH: .31 (7.8mm)
  8. PART IS RoHS COMPLIANT

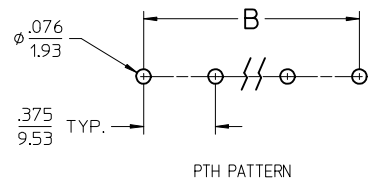

REF. THIS DRAWING SUPERSEDES SD-38720-009 REV-A (ME10 DOC)

8	XX	SCREW & WASHER, #6-32 PH/SL (-50 OPT)	STEEL	CLEAR ZN CHROMATE
7	XX	SCREW, #6-32 PH/SL, -49 OPT	BRASS	NICKEL PLATED
6	XX	SCREW, #6-32 PH/SL,	STEEL	CLEAR ZN CHROMATE
5	XX	TERMINAL, WIRE WRAP (-81 OPT)	BRASS	TIN PLATED
4	XX	TERMINAL, WIRE WRAP (-75 OPT)	BRASS	TIN PLATED
3	XX	TERMINAL, WIRE WRAP (-55 OPT)	BRASS	TIN PLATED
2	XX	TERMINAL, WIRE WRAP (.47 STD)	BRASS	TIN PLATED
1	1	INSULATOR	PBT	BLACK
ITEM	QTY.	DESCRIPTION	MATERIAL	FINISH

<b>REDRAWN</b> EC NO: IFC2016-1570 DRAWN BY: DRWINRSTONE 2016/05/20 CHKD BY: ZIELINSKI 2016/05/24 APPR: BRUPERT 2016/05/26 REV: A	<b>QUALITY SYMBOLS</b> ▽=0 ▽=0	<b>GENERAL TOLERANCES (UNLESS SPECIFIED)</b>		<b>DIMENSION STYLE</b> IN/MM		<b>SCALE</b> 2:1	<b>DESIGN UNITS</b> INCH	THIRD ANGLE PROJECTION
		4 PLACES ± --- ± --- 3 PLACES ± --- ± .005 2 PLACES ± 0.13 ± .01 1 PLACE ± 0.3 ± --- 0 PLACE ± --- ± ---		DRAWN BY: RSTONE DATE: 2016/05/20 CHECKED BY: M ZIELINSKI DATE: 2016/05/24 APPROVED BY: BRUPERT DATE: 2016/05/26		<b>SR, BTS, PC, INSULATED NO MOUNTING ENDS .375 (9.53MM)</b>		
		ANGULAR ± --- °		MATERIAL NO.		<b>molex</b>		
		DRAFT WHERE APPLICABLE MUST REMAIN WITHIN DIMENSIONS		SEE TABLE		DOCUMENT NO. SD-38720-015		SHEET NO. 1 OF 1

THIS DRAWING CONTAINS INFORMATION THAT IS PROPRIETARY TO MOLEX INCORPORATED AND SHOULD NOT BE USED WITHOUT WRITTEN PERMISSION