

iW-RainboW-G33M
i.MX8M SMARC SOM HEAT SPREADER
ORDERING PART NUMBER: iW-HSPALU-CLASLR-SC02

RELEASE HISTORY			
REL	CHANGES	DATE	BY
1.0	INITIAL RELEASE	15 JUL. 2020	IQBAL

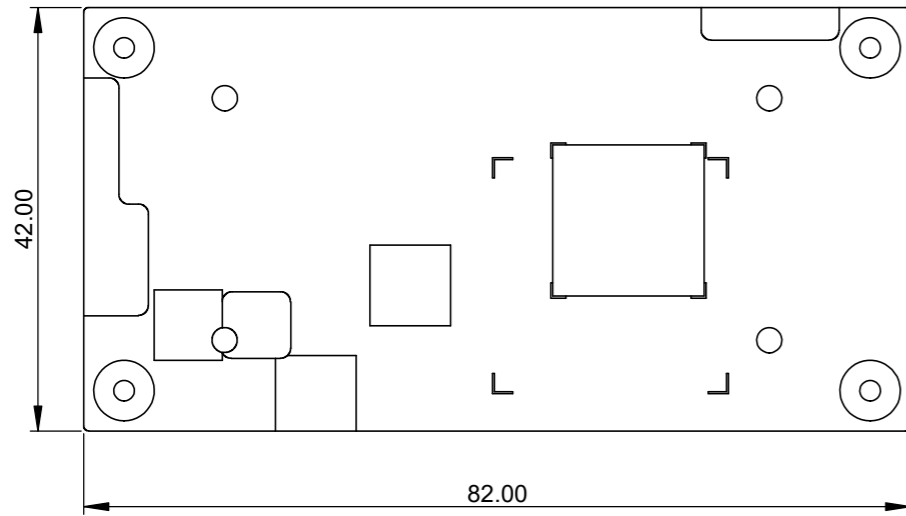

Fig 1.1

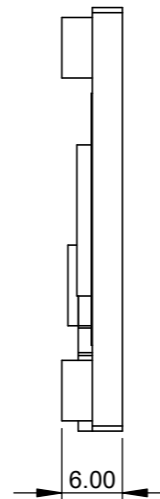

Fig 1.2

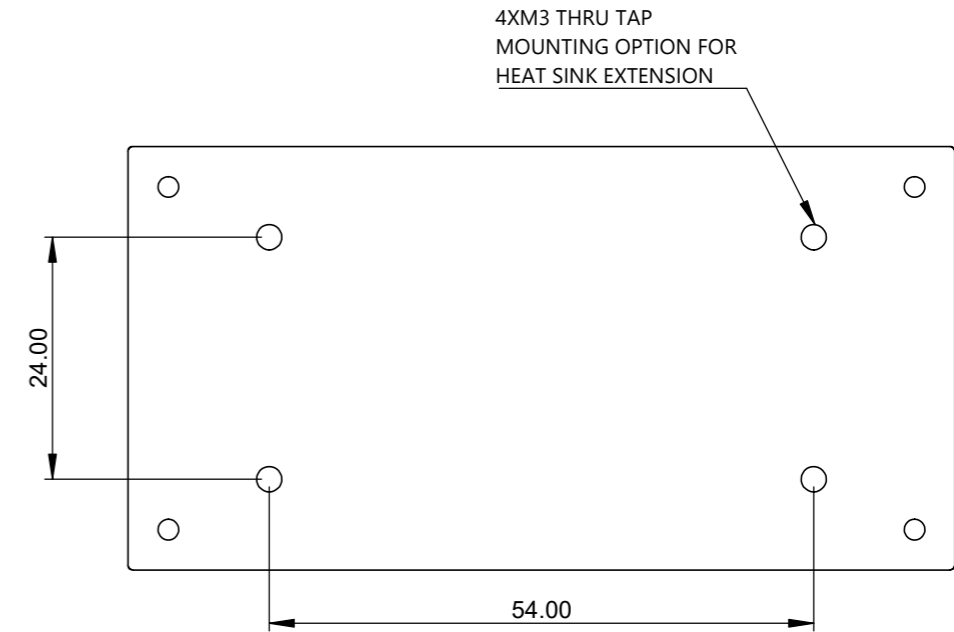

Fig 1.3

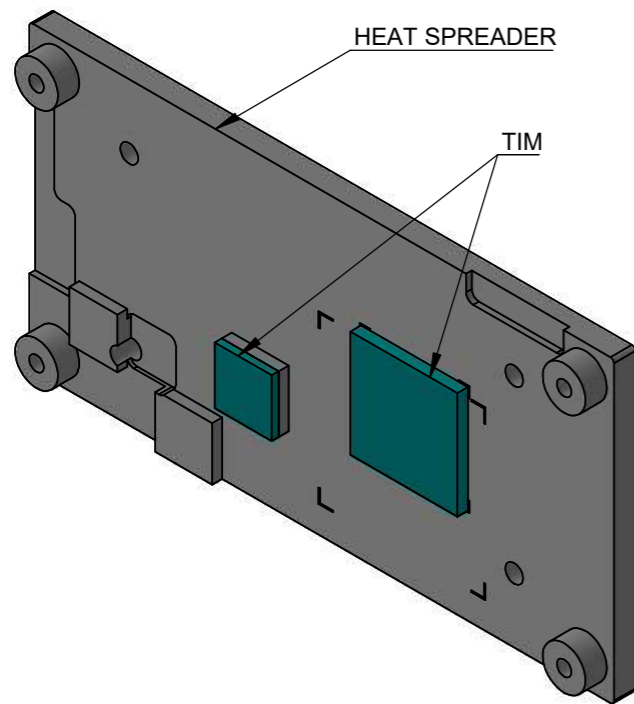

Fig 1.4

TABLE 1.1: TIM SPECIFICATIONS	
MATERIAL	SILICONE RUBBER (BASE MATERIAL)
THERMAL CONDUCTIVITY	6.2W/mK
FLAME RATING	UL 94 V-0
HARDNESS	50 Shore 00
WORKING TEMP.	-50~+150 °C
ROHS	YES

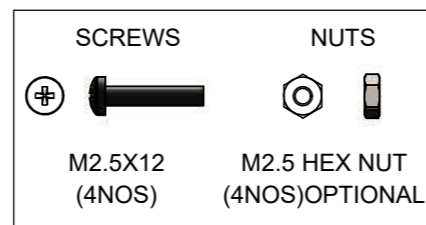

Fig 1.5

NOTES:
 ALL DIMENSIONS ARE IN mm.
 SCALE: 4:3

DRAWN BY	IQBAL
CHECKED BY	GANGADHAR
APPROVED BY	PRADAP
THIS DRAWING SHEET IS PROPERITY OF iWAVE SYSTEMS TECHNOLOGIES Pvt. Ltd.	
GENERAL TOLERANCES :	
X: ± 0.25	
.X: ± 0.1	
.XX: ± 0.01	

		iWave System Technologies Private Limited, 7/B, 29th Main, BTM Layout, 2nd Stage, Bangalore-560076, India.	
		DRAWING NO: iW-HSPALU-CLASLR-SC02-DS	
MATERIAL : AL 6063-T5 ALLOY		WEIGHT: 29 g	
FINISH : CLEAR ANODIZED			
TITLE: G33M-SMARC SOM HEAT SPREADER DATA SHEET		REV: 3.0	REL: 1.0
DATE : 15 JUL. 2020		SHEET 1 OF 1	