

# L96 Hardware Design

## GNSS Module Series

Rev. L96\_Hardware\_Design\_V1.3

Date: 2018-08-20

Status: Released



**Our aim is to provide customers with timely and comprehensive service. For any assistance, please contact our company headquarters:**

**Quectel Wireless Solutions Co., Ltd.**

7<sup>th</sup> Floor, Hongye Building, No.1801 Hongmei Road, Xuhui District, Shanghai 200233, China

Tel: +86 21 5108 6236

Email: [info@quectel.com](mailto:info@quectel.com)

**Or our local office. For more information, please visit:**

<http://www.quectel.com/support/sales.htm>

**For technical support, or to report documentation errors, please visit:**

<http://www.quectel.com/support/technical.htm>

Or email to: [support@quectel.com](mailto:support@quectel.com)

**GENERAL NOTES**

QUECTEL OFFERS THE INFORMATION AS A SERVICE TO ITS CUSTOMERS. THE INFORMATION PROVIDED IS BASED UPON CUSTOMERS' REQUIREMENTS. QUECTEL MAKES EVERY EFFORT TO ENSURE THE QUALITY OF THE INFORMATION IT MAKES AVAILABLE. QUECTEL DOES NOT MAKE ANY WARRANTY AS TO THE INFORMATION CONTAINED HEREIN, AND DOES NOT ACCEPT ANY LIABILITY FOR ANY INJURY, LOSS OR DAMAGE OF ANY KIND INCURRED BY USE OF OR RELIANCE UPON THE INFORMATION. ALL INFORMATION SUPPLIED HEREIN IS SUBJECT TO CHANGE WITHOUT PRIOR NOTICE.

**COPYRIGHT**

THE INFORMATION CONTAINED HERE IS PROPRIETARY TECHNICAL INFORMATION OF QUECTEL WIRELESS SOLUTIONS CO., LTD. TRANSMITTING, REPRODUCTION, DISSEMINATION AND EDITING OF THIS DOCUMENT AS WELL AS UTILIZATION OF THE CONTENT ARE FORBIDDEN WITHOUT PERMISSION. OFFENDERS WILL BE HELD LIABLE FOR PAYMENT OF DAMAGES. ALL RIGHTS ARE RESERVED IN THE EVENT OF A PATENT GRANT OR REGISTRATION OF A UTILITY MODEL OR DESIGN.

***Copyright © Quectel Wireless Solutions Co., Ltd. 2018. All rights reserved.***

# About the Document

## History

Revision	Date	Author	Description
1.0	2017-10-27	Brooke WANG/ Kane ZHU	Initial
1.1	2017-12-22	Brooke WANG	<ol style="list-style-type: none"> <li>Enabled 3D_FIX, JAM_DET and GEO_FENCE interfaces for the module, and updated Figure 2 (Pin Assignment) for the three pins.</li> <li>Added the description of 3D_FIX, JAM_DET and GEO_FENCE interfaces in Table 4 (Pin Description) and Chapter 3.8~3.10.</li> <li>Updated the thickness of the module in Table 1 (Key Features) and Chapter 6 (Mechanical Dimensions).</li> <li>Updated the recommended footprint (Figure 22).</li> </ol>
1.2	2018-02-13	Brooke WANG/ Gene LI	<ol style="list-style-type: none"> <li>Added a note about I2C interface in Chapter 2.2 and 3.7.</li> <li>Updated the block diagram in Chapter 2.3.</li> </ol>
1.3	2018-08-20	Brooke WANG/ Kane ZHU	<ol style="list-style-type: none"> <li>Updated the pin names of L96 module.</li> <li>Updated the module state switch (Table 5).</li> <li>Updated the average current consumption in GLP mode and normal mode (Table 8).</li> <li>Updated the RS-232 level shift circuit (Figure 11).</li> <li>Updated the recommended antenna specifications (Table 10).</li> <li>Updated the current consumption (Table 13).</li> <li>Updated the storage information (Chapter 7.1) and the reflow soldering thermal profile and related parameters (Chapter 7.2).</li> </ol>

## Contents

<b>About the Document</b> .....	<b>2</b>
<b>Contents</b> .....	<b>3</b>
<b>Table Index</b> .....	<b>5</b>
<b>Figure Index</b> .....	<b>6</b>
<b>1 Introduction</b> .....	<b>7</b>
1.1. General Description.....	7
<b>2 Product Concept</b> .....	<b>9</b>
2.1. General Description.....	9
2.2. Key Features.....	10
2.3. Block Diagram.....	11
2.4. Evaluation Board.....	12
2.5. Protocols Supported by the Module.....	12
<b>3 Application Interfaces</b> .....	<b>13</b>
3.1. Pin Assignment.....	13
3.2. Pin Description.....	14
3.3. Power Supply.....	16
3.4. Operation Modes.....	17
3.4.1. Full on Mode.....	18
3.4.2. Standby Mode.....	19
3.4.3. Backup Mode.....	20
3.4.4. Periodic Mode.....	21
3.4.5. AlwaysLocate™ Mode.....	23
3.4.6. GLP Mode.....	24
3.5. Reset.....	26
3.6. UART Interface.....	27
3.7. I2C Interface.....	28
3.8. 3D_FIX Interface.....	29
3.9. JAM_IND Interface.....	29
3.10. GEO_FENCE Interface.....	30
3.11. EASY Autonomous AGPS Technology.....	30
3.12. EPO Offline AGPS Technology.....	31
3.13. Multi-tone AIC.....	31
3.14. ANTON.....	31
3.15. LOCUS.....	32
3.16. PPS VS. NMEA.....	32
<b>4 Antenna Interfaces</b> .....	<b>34</b>
4.1. Antenna Specifications.....	34
4.2. Recommended Circuits for Antenna.....	34
4.2.1. Active Antenna Reference Designs.....	35

4.2.1.1.	Reference Design of Active Antenna without ANTON.....	35
4.2.1.2.	Reference Design of Active Antenna with ANTON.....	35
4.2.2.	Passive Antenna Reference Designs .....	36
4.2.2.1.	Reference Design of Passive Antenna without External LNA.....	36
4.2.2.2.	Reference Design of Passive Antenna with External LNA.....	37
4.2.3.	Internal Antenna .....	38
4.3.	PCB Layout Suggestion .....	39
<b>5</b>	<b>Electrical, Reliability and Radio Characteristics .....</b>	<b>40</b>
5.1.	Absolute Maximum Ratings .....	40
5.2.	Operating Conditions .....	41
5.3.	Current Consumption .....	41
5.4.	Reliability Tests.....	42
5.5.	ESD Protection.....	42
<b>6</b>	<b>Mechanical Dimensions .....</b>	<b>44</b>
6.1.	Top and Side Dimensions of the Module .....	44
6.2.	Bottom Dimensions and Recommended Footprint.....	45
6.3.	Top and Bottom Views of the Module .....	46
<b>7</b>	<b>Storage, Manufacturing and Packaging .....</b>	<b>47</b>
7.1.	Storage .....	47
7.2.	Manufacturing and Soldering .....	47
7.3.	Tape and Reel Packaging .....	49
<b>8</b>	<b>Appendix A References.....</b>	<b>51</b>

## Table Index

TABLE 1: KEY FEATURES .....	10
TABLE 2: SUPPORTED PROTOCOLS.....	12
TABLE 3: I/O PARAMETERS DEFINITION.....	14
TABLE 4: PIN DESCRIPTION .....	14
TABLE 5: MODULE STATE SWITCH.....	17
TABLE 6: DEFAULT CONFIGURATION.....	18
TABLE 7: FORMAT OF THE PMTK COMMAND ENABLING PERIODIC MODE.....	21
TABLE 8: AVERAGE CURRENT CONSUMPTION IN GLP MODE AND NORMAL MODE .....	25
TABLE 9: GEO_FENCE VOLTAGE LEVEL STATUS IN DIFFERENT URC REPORT MODES .....	30
TABLE 10: RECOMMENDED ANTENNA SPECIFICATIONS.....	34
TABLE 11: ABSOLUTE MAXIMUM RATINGS .....	40
TABLE 12: POWER SUPPLY RATINGS .....	41
TABLE 13: CURRENT CONSUMPTION .....	41
TABLE 14: RELIABILITY TESTS.....	42
TABLE 15: RECOMMENDED THERMAL PROFILE PARAMETERS .....	48
TABLE 16: REEL PACKAGING .....	50
TABLE 17: RELATED DOCUMENTS.....	51
TABLE 18: TERMS AND ABBREVIATIONS .....	51

## Figure Index

FIGURE 1: BLOCK DIAGRAM .....	11
FIGURE 2: PIN ASSIGNMENT .....	13
FIGURE 3: INTERNAL POWER CONSTRUCTION.....	17
FIGURE 4: RTC SUPPLY FROM NON-CHARGEABLE BATTERY.....	20
FIGURE 5: REFERENCE CHARGING CIRCUIT FOR RECHARGEABLE BATTERIES .....	21
FIGURE 6: OPERATION MECHANISM OF PERIODIC MODE.....	23
FIGURE 7: POWER CONSUMPTION IN DIFFERENT SCENARIOS (ALWAYSLOCATE™ MODE).....	24
FIGURE 8: REFERENCE OC CIRCUIT FOR MODULE RESET.....	26
FIGURE 9: MODULE RESET TIMING .....	26
FIGURE 10: REFERENCE DESIGN FOR UART PORT.....	27
FIGURE 11: RS-232 LEVEL SHIFT CIRCUIT .....	28
FIGURE 12: REFERENCE DESIGN FOR I2C INTERFACE .....	29
FIGURE 13: PPS VS. NMEA TIMING .....	32
FIGURE 14: REFERENCE DESIGN FOR ACTIVE ANTENNA WITHOUT ANTON .....	35
FIGURE 15: REFERENCE DESIGN FOR ACTIVE ANTENNA WITH ANTON.....	36
FIGURE 16: REFERENCE DESIGN FOR PASSIVE ANTENNA WITHOUT LNA .....	37
FIGURE 17: REFERENCE DESIGN FOR PASSIVE ANTENNA WITH LNA.....	37
FIGURE 18: REFERENCE DESIGN FOR INTERNAL ANTENNA .....	38
FIGURE 19: PCB LAYOUT.....	39
FIGURE 20: TOP AND SIDE DIMENSIONS .....	44
FIGURE 21: BOTTOM DIMENSIONS.....	45
FIGURE 22: RECOMMENDED FOOTPRINT .....	45
FIGURE 23: TOP VIEW OF THE MODULE .....	46
FIGURE 24: BOTTOM VIEW OF THE MODULE.....	46
FIGURE 25: RECOMMENDED REFLOW SOLDERING THERMAL PROFILE.....	48
FIGURE 26: TAPE AND REEL SPECIFICATIONS .....	49

# 1 Introduction

This document defines and specifies L96 GNSS module. It describes the hardware interfaces, external application reference circuits, mechanical size and air interface of L96 module.

This document can help customers quickly understand the interface specifications, as well as electrical and mechanical details of L96 module. Other documents such as L96 software application notes and user guides are also provided. These documents ensure customers can use L96 module to design and set up mobile applications quickly.

## 1.1. General Description

The following safety precautions must be observed during all phases of operation, such as usage, service or repair of any cellular terminal or mobile incorporating L96 module. Manufacturers of the cellular terminal should send the following safety information to users and operating personnel, and incorporate these guidelines into all manuals supplied with the product. If not so, Quectel assumes no liability for customers' failure to comply with these precautions.



Full attention must be given to driving at all times in order to reduce the risk of an accident. Using a mobile while driving (even with a handsfree kit) causes distraction and can lead to an accident. Please comply with laws and regulations restricting the use of wireless devices while driving.



Switch off the cellular terminal or mobile before boarding an aircraft. The operation of wireless appliances in an aircraft is forbidden to prevent interference with communication systems. If the device offers an Airplane Mode, then it should be enabled prior to boarding an aircraft. Please consult the airline staff for more restrictions on the use of wireless devices on boarding the aircraft.



Wireless devices may cause interference on sensitive medical equipment, so please be aware of the restrictions on the use of wireless devices when in hospitals, clinics or other healthcare facilities.





Cellular terminals or mobiles operating over radio signals and cellular network cannot be guaranteed to connect in all possible conditions (for example, with unpaid bills or with an invalid (U)SIM card). When emergent help is needed in such conditions, please remember using emergency call. In order to make or receive a call, the cellular terminal or mobile must be switched on in a service area with adequate cellular signal strength.



The cellular terminal or mobile contains a transmitter and receiver. When it is ON, it receives and transmits radio frequency signals. RF interference can occur if it is used close to TV set, radio, computer or other electric equipment.



In locations with potentially explosive atmospheres, obey all posted signs to turn off wireless devices such as your phone or other cellular terminals. Areas with potentially explosive atmospheres include fuelling areas, below decks on boats, fuel or chemical transfer or storage facilities, areas where the air contains chemicals or particles such as grain, dust or metal powders, etc.

# 2 Product Concept

## 2.1. General Description

L96 is a single receiver module integrated with GPS, GLONASS, Galileo (RLM supported) and BeiDou systems. It is able to achieve the industry's highest level of sensitivity, accuracy and TTFF with the lowest power consumption in a small-footprint lead-free package. The embedded flash memory provides a capacity for storing user-specific configurations and allows for future updates.

The module supports multiple positioning and navigation systems including autonomous GPS, GLONASS, Galileo, BeiDou, SBAS (including WAAS, EGNOS, MSAS and GAGAN), QZSS, DGPS, and AGPS.

Designed with several advanced power saving modes including periodic, AlwaysLocate™, standby and backup modes, L96 has excellent low-power consumption in different scenarios.

EASY technology as one kind of AGPS is a key feature of L96 module. Capable of collecting and processing all internal aiding information like GPS time, ephemeris, last position, etc., the GNSS module delivers a very short TTFF in either Hot or Warm start.

L96 module is an SMD type module with a compact 14.0mm × 9.6mm × 2.0mm form factor. It can be embedded in customers' applications through the 31-pin pads with 1.0mm pitch. It provides necessary hardware interfaces for connection with the main PCB.

The module is fully compliant with EU RoHS directive.

## 2.2. Key Features

**Table 1: Key Features**

Features	Implementation
Receiver Type <sup>1)</sup>	<ul style="list-style-type: none"> <li>● GPS L1 C/A (1575.42MHz)</li> <li>● GLONASS L1 C/A (1598.0625MHz~1605.375MHz)</li> <li>● Galileo L1 C/A (1575.42MHz)</li> <li>● BeiDou B1 C/A (1561.098MHz)</li> </ul>
Receiver Frequency	<ul style="list-style-type: none"> <li>● GPS frequency: 1575.42MHz±1.023MHz</li> <li>● GLONASS frequency: 1602MHz±4MHz</li> <li>● Galileo frequency: 1575.42MHz±2MHz</li> <li>● BeiDou frequency: 1561.098MHz±2MHz</li> </ul>
Power Supply	<ul style="list-style-type: none"> <li>● Supply voltage: 2.8V~4.3V</li> <li>● Typical: 3.3V</li> </ul>
Power Consumption (GPS+GLONASS)	<ul style="list-style-type: none"> <li>● Tracking: 22mA @-130dBm, VCC=3.3V</li> <li>● Acquisition: 25mA @-130dBm, VCC=3.3V</li> <li>● Backup: 7uA @-130dBm, V_BCKP=3.3V</li> </ul>
Sensitivity	<ul style="list-style-type: none"> <li>● Acquisition: -148dBm</li> <li>● Reacquisition: -160dBm</li> <li>● Tracking: -165dBm</li> </ul>
TTF (EASY Enabled)	<ul style="list-style-type: none"> <li>● Cold Start: &lt;15s average @-130dBm</li> <li>● Warm Start: &lt;5s average @-130dBm</li> <li>● Hot Start: 1s average @-130dBm</li> </ul>
TTF (EASY Disabled)	<ul style="list-style-type: none"> <li>● Cold Start (Autonomous): &lt;35s average @-130dBm</li> <li>● Warm Start (Autonomous): &lt;30s average @-130dBm</li> <li>● Hot Start (Autonomous): 1s average @-130dBm</li> </ul>
Horizontal Position Accuracy (Autonomous)	<ul style="list-style-type: none"> <li>● &lt;2.5m CEP @-130dBm</li> </ul>
Update Rate	<ul style="list-style-type: none"> <li>● 1Hz by default, maximally up to 10Hz</li> </ul>
Accuracy of 1PPS Signal	<ul style="list-style-type: none"> <li>● Typical accuracy: &lt;10ns</li> <li>● Time pulse width: 100ms</li> </ul>
Velocity Accuracy	<ul style="list-style-type: none"> <li>● Without aid: 0.1m/s</li> </ul>
Acceleration Accuracy	<ul style="list-style-type: none"> <li>● Without aid: 0.1m/s<sup>2</sup></li> </ul>
Dynamic Performance	<ul style="list-style-type: none"> <li>● Maximum Altitude: 18000m</li> <li>● Maximum Velocity: 515m/s</li> <li>● Acceleration: 4G</li> </ul>
UART Interface	<ul style="list-style-type: none"> <li>● UART port: TXD1 and RXD1</li> <li>● Supports baud rate from 4800bps to 115200bps; 9600bps by</li> </ul>

	default
	<ul style="list-style-type: none"> <li>● UART port is used for NMEA output, PMTK/PQ command input and firmware upgrade</li> </ul>
I2C Interface <sup>2)</sup>	<ul style="list-style-type: none"> <li>● Supports fast mode, with bit rate up to 400Kbps</li> <li>● Supports 7-bit address</li> <li>● Outputs NMEA data by default when reading; it can also receive PMTK/PQ commands via I2C bus</li> </ul>
Temperature Range	<ul style="list-style-type: none"> <li>● Normal operation temperature range: -40°C ~ +85°C</li> <li>● Storage temperature range: -40°C ~ +90°C</li> </ul>
Physical Characteristics	<ul style="list-style-type: none"> <li>● Size: (14.0±0.15)mm × (9.6±0.15)mm × (2.0±0.20)mm</li> <li>● Weight: Approx. 0.6g</li> </ul>

### NOTES

- <sup>1)</sup> The default GNSS configuration of L96 is GPS+GLONASS. For more details about the GNSS configuration, please refer to **document [2]**.
- <sup>2)</sup> I2C interface is supported only on firmware versions ended with "SC". In other firmware versions, I2C\_SDA and I2C\_SCL pins are used for RTCM data output. When I2C interface is supported, NEMA data should be outputted via I2C interface rather than UART interface, otherwise there maybe NEMA data loss.

## 2.3. Block Diagram

The following figure shows the block diagram of L96 module. It consists of a single chip GNSS IC which includes RF/Baseband parts, an LNA, a SAW filter, a TCXO and a crystal oscillator.

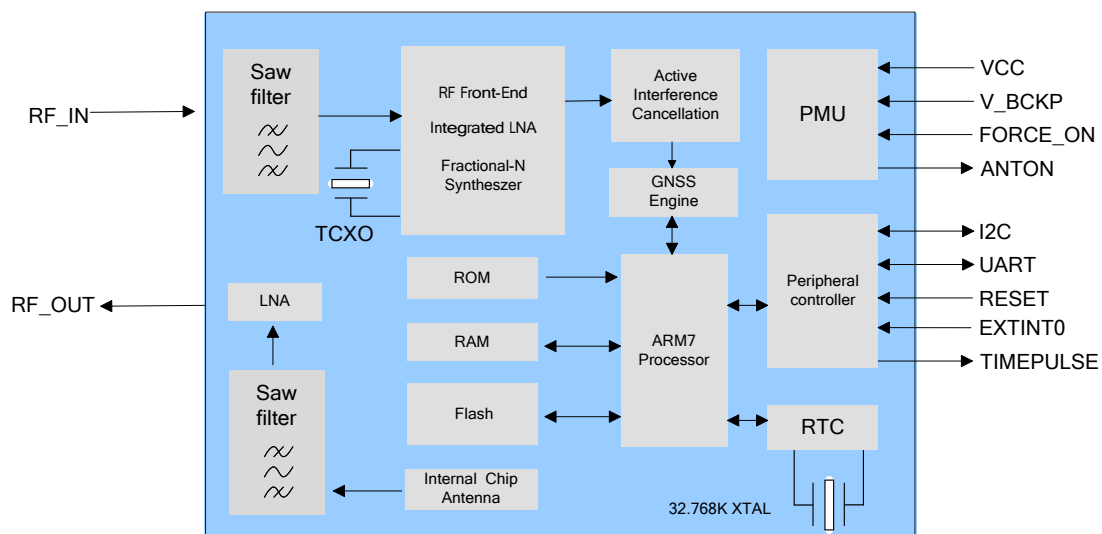

**Figure 1: Block Diagram**

## 2.4. Evaluation Board

In order to help customers to use L96 module on their applications, Quectel supplies the evaluation board (EVB), Micro-USB cable, active antenna and other peripherals to test the module. For more details, please refer to **document [1]**.

## 2.5. Protocols Supported by the Module

Table 2: Supported Protocols

Protocol	Type
NMEA	ASCII, 0183, 4.10
PMTK	MTK proprietary protocol
PQ	Quectel proprietary protocol

### NOTES

1. Please refer to **document [2]** for details of NMEA standard protocol and MTK proprietary protocol.
2. Please refer to **document [6]** for details of Quectel proprietary protocol.

# 3 Application Interfaces

The module is equipped with a 31-pin SMT pad that connects to customers' application platforms. Sub-interfaces included in the pad are described in details in the following chapters.

## 3.1. Pin Assignment

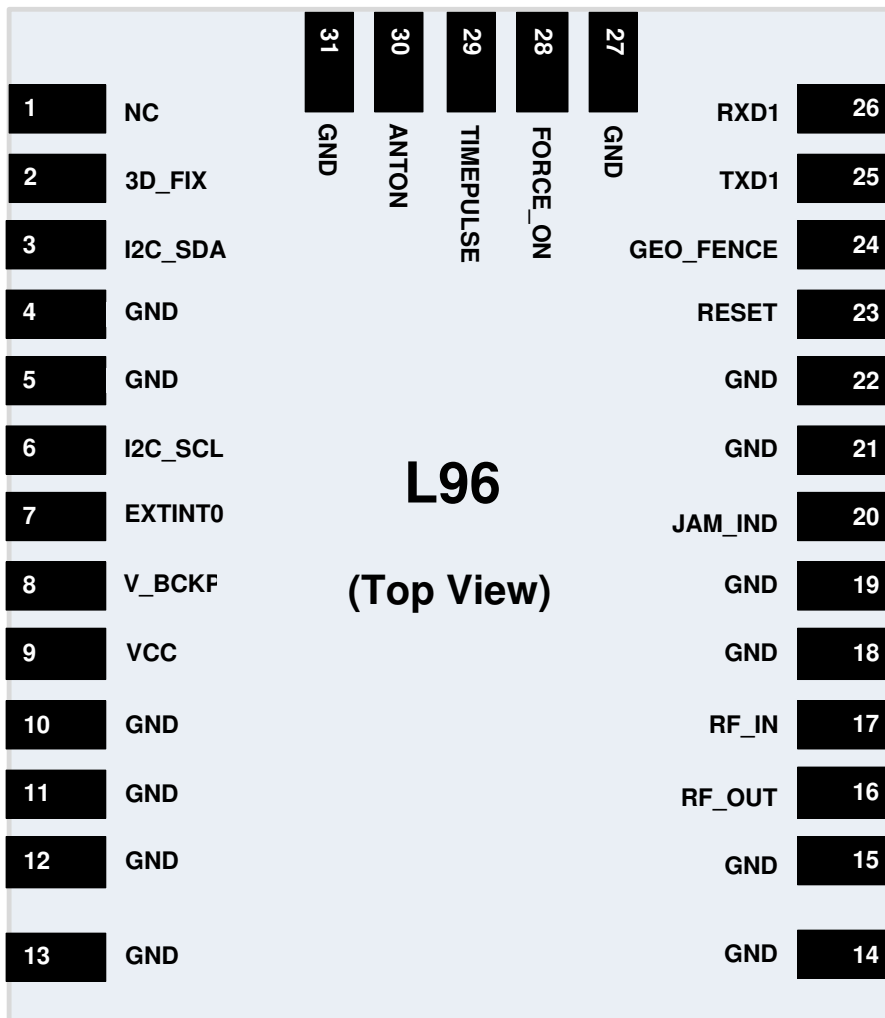

Figure 2: Pin Assignment

## 3.2. Pin Description

**Table 3: I/O Parameters Definition**

Type	Description
IO	Bidirectional
DI	Digital input
DO	Digital output
PI	Power input
PO	Power output
AI	Analog input
AO	Analog output

**Table 4: Pin Description**

Power Supply					
Pin Name	Pin No.	I/O	Description	DC Characteristics	Comment
V_BCKP	8	PI	Backup power supply	V <sub>max</sub> =4.5V V <sub>min</sub> =1.5V V <sub>nom</sub> =3.3V I <sub>V_BCKP</sub> =7uA @Backup mode	Supply power for RTC domain when VCC is powered off.
VCC	9	PI	Main power supply	V <sub>max</sub> =4.3V V <sub>min</sub> =2.8V V <sub>nom</sub> =3.3V	Assure load current not less than 150mA.
Reset					
Pin Name	Pin No.	I/O	Description	DC Characteristics	Comment
RESET	23	DI	Reset the module	V <sub>ILmin</sub> =-0.3V V <sub>ILmax</sub> =0.7V V <sub>IHmin</sub> =2.1V V <sub>IHmax</sub> =3.1V	Active low. If unused, keep this pin open or connected to VCC.
UART Port					

Pin Name	Pin No.	I/O	Description	DC Characteristics	Comment
TXD1	25	DO	Transmit data	$V_{OLmax}=0.42V$ $V_{OHmin}=2.4V$ $V_{OHnom}=2.8V$	UART port is used for NMEA output, PMTK/PQ command input and firmware upgrade.
RXD1	26	DI	Receive data	$V_{ILmin}=-0.3V$ $V_{ILmax}=0.7V$ $V_{IHmin}=2.1V$ $V_{IHmax}=3.1V$	

#### RF Interface

Pin Name	Pin No.	I/O	Description	DC Characteristics	Comment
RF_OUT	16	AO	RF signal output		50Ω characteristic impedance.
RF_IN	17	AI	RF signal input		Refer to <b>Chapter 4</b> for details.

#### Other Interfaces

Pin Name	Pin No.	I/O	Description	DC Characteristics	Comment
ANTON	30	PO	Used as external LNA control pin and active antenna power control pin in power saving mode.	$V_{OLmax}=0.42V$ $V_{OHmin}=2.4V$ $V_{OHnom}=2.8V$	If unused, keep this pin open.
EXTINT0	7	DI	Used to enter into or exit from standby mode.	$V_{ILmin}=-0.3V$ $V_{ILmax}=0.7V$ $V_{IHmin}=2.1V$ $V_{IHmax}=3.1V$	It is pulled up internally. It is edge-triggered. If unused, keep this pin open.
TIMEPULSE	29	DO	One pulse per second	$V_{OLmax}=0.42V$ $V_{OHmin}=2.4V$ $V_{OHnom}=2.8V$	Synchronized at rising edge, the pulse width is 100ms. If unused, keep this pin open.
FORCE_ON	28	DI	Logic high of the pin will force the module to be woken up from backup mode.	$V_{ILmin}=-0.3V$ $V_{ILmax}=0.7V$ $V_{IHmin}=2.1V$ $V_{IHmax}=3.1V$	Keep this pin open or pulled low before entering into backup mode. It belongs to RTC domain.
I2C_SDA	3	IO	I2C serial data	$V_{ILmin}=-0.3V$	I2C interface outputs



I2C_SCL	6	IO	I2C serial clock	$V_{ILmax}=0.7V$ $V_{IHmin}=2.1V$ $V_{IHmax}=3.1V$ $V_{OLmax}=0.42V$ $V_{OHmin}=2.4V$ $V_{OHnom}=2.8V$	NMEA data. It can also receive PMTK/PQ commands via I2C bus.
3D_FIX	2	DO	3D fix indicator	$V_{OLmax}=0.42V$ $V_{OHmin}=2.4V$ $V_{OHnom}=2.8V$	Active high. If unused, keep this pin open.
JAM_IND	20	DO	Jamming detection indicator	$V_{OLmax}=0.42V$ $V_{OHmin}=2.4V$ $V_{OHnom}=2.8V$	If unused, keep this pin open.
GEO_FENCE	24	DO	Geo-fence boundary indicator	$V_{OLmax}=0.42V$ $V_{OHmin}=2.4V$ $V_{OHnom}=2.8V$	If unused, keep this pin open.
GND	4,5,10 ~15, 18,19, 21,22, 27,31		Ground		
NC	1				Keep this pin open.

### 3.3. Power Supply

VCC pin supplies power for BB, RF, I/O and RTC domains. The load current of VCC pin varies according to the VCC level, processor load and satellite acquisition. It is important to supply sufficient current and make the power clean and stable. It is recommended for customers to choose an LDO with minimum output current of 150mA as the power supply, and add a 10uF and a 100nF decoupling capacitor combination as well as a TVS near the VCC pin.

The V\_BCKP pin supplies power for RTC domain. A cell battery with the combination of a 4.7uF and a 100nF capacitor is recommended to be placed nearby V\_BCKP pin. The voltage of RTC domain ranges from 1.5V to 4.5V. In order to achieve better Time To First Fix (TTFF), RTC domain should be valid all the time so as to supply power for SRAM memory which contains all the necessary GNSS information for quick start-up and a small amount of user configuration variables.

The module's internal power construction is shown as below.

VCC pin supplies power not only for PMU but also for RTC domain, while V\_BCKP supplies power for RTC domain only. The two diodes in the following figure construct an OR gate to supply power for RTC domain. FORCE\_ON pin belongs to RTC domain. The signal which is marked in red in the following figure

can be used to control ON/OFF of the switch. The following operations will close or open the switch:

- The switch will be closed by default when VCC is supplying power (VCC off → on).
- Based on the above step, FORCE\_ON open or low and sending PMTK command can open the switch (full on → backup).
- Based on the above step, FORCE\_ON logic high can close the switch (backup → full on).

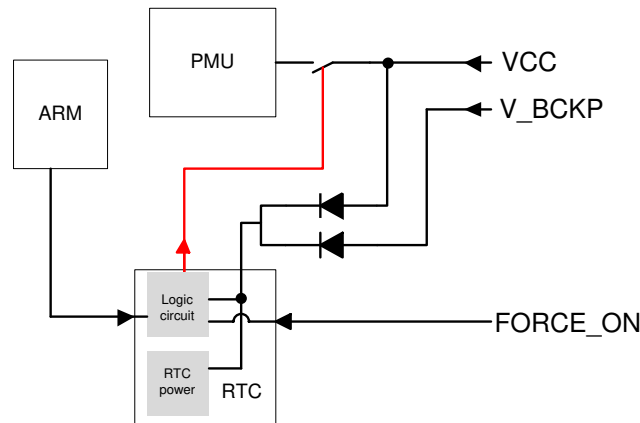

**Figure 3: Internal Power Construction**

### 3.4. Operation Modes

The table below briefly illustrates the relationship among different operation modes of L96 module.

**Table 5: Module State Switch**

Current Mode	Next Mode					
	Backup	Standby	Full on	Periodic	Always Locate™	GLP
Backup	/	N/A	Refer to <b>Chapter 3.4.3</b>	N/A	N/A	N/A
Standby	N/A	/	Refer to <b>Chapter 3.4.2</b>	N/A	N/A	N/A
Full on	Refer to <b>Chapter 3.4.3</b>	Refer to <b>Chapter 3.4.2</b>	/	PMTK225	PMTK225	Refer to <b>Chapter 3.4.6</b>
GLP	N/A	N/A	Refer to <b>Chapter 3.4.6</b>	N/A	N/A	/

Periodic	N/A	N/A	Refer to <b>Chapter 3.4.4</b>	/	N/A	N/A
AlwaysLocate™	N/A	N/A	Refer to <b>Chapter 3.4.5</b>	N/A	/	N/A

**NOTE**

Please refer to **document [2]** for more details of MTK proprietary protocol (PMTK commands).

### 3.4.1. Full on Mode

Full on mode includes tracking mode and acquisition mode. Acquisition mode is defined as the module starts to search satellites, and to determine the visible satellites, coarse carrier frequency & code phase of satellite signals. When the acquisition is completed, it switches to tracking mode automatically. Tracking mode is defined as the module tracks satellites and demodulates the navigation data from specific satellites.

Whether both VCC and V\_BCKP pins are valid or only VCC is valid, the module will enter into full on mode automatically and follow the default configuration as below. Please refer to **Chapter 3.3** to have a good comprehension of internal power construction. Customers also can use PMTK commands to change the configuration to satisfy different requirements.

**Table 6: Default Configuration**

Item	Configuration	Comment
Baud Rate	9600bps	
Protocol	NMEA	RMC, VTG, GGA, GSA, GSV and GLL
Update Rate	1Hz	
SBAS	Enable	
AIC	Enable	
LOCUS	Disable	
EASY Technology	Enable	EASY will be disabled automatically when the update rate exceeds 1Hz.
GNSS	GPS+GLONASS	

In full on mode, the power consumption will comply with the following regulation:

After the module is powered on, the average current will be decreased to the acquisition current listed in **Table 13** and this state is defined as acquisition state. The state will last for several minutes until it switches to tracking state automatically. The current consumption in tracking state is less than that in acquisition state and the value is also listed in **Table 13**.

The following PMTK commands can be used to switch among multiple positioning systems:

- \$PMTK353,0,1,0,0,0\*2A: Search GLONASS satellites only
- \$PMTK353,1,0,0,0,0\*2A: Search GPS satellites only
- \$PMTK353,1,1,0,0,0\*2B: Search GPS and GLONASS satellites
- \$PMTK353,1,1,1,0,0\*2A: Search GPS, GLONASS, Galileo satellites

**NOTE**

RMC, VTG, GGA, GSA, GSV and GLL refer to output types of NMEA, which stand for functions as: RMC (Recommended Minimum Specific GNSS Data), VTG (Course over Ground and Ground Speed, Horizontal Course and Horizontal Velocity), GGA (GPS Fix Data), GSA (GNSS DOP and Active Satellites), GSV (GNSS Satellites in View), GLL (Geographic Position – Latitude/Longitude).

### 3.4.2. Standby Mode

Standby mode is a low-power consumption mode. In standby mode, the internal core and I/O power domain are still active, but RF and TCXO are powered off, and the module stops satellites search and navigation. UART is still accessible through executing PMTK commands or sending any other data, but there are no NMEA messages output.

There are two ways to enter into and exit from standby mode.

- **Using EXTINT0 pin:** EXTINT0 is pulled up internally by default. Pulling it low will make the module enter into standby mode and then releasing it will make the module back to full on mode. Please note that pulling EXTINT0 pin down to ground will cause extra current consumption which makes the typical current consumption in standby mode reach up to about 600uA @VCC=3.3V.
- **Using PMTK command:** Sending "\$PMTK161,0\*28" Command will make the module enter into standby mode. Sending any data via UART will make the module exit from standby mode as UART is still accessible in standby mode. When the module exits from standby mode, it will use all internal aiding information like GPS time, ephemeris, last position, etc. to get the fastest possible TTFF in either Hot or Warm start. The typical current consumption in standby mode is about 500uA @VCC=3.3V.

**NOTE**

Considering the EXTINT0 pin is edge-triggered, it is recommended to set the GPIO of customers' MCU which controls EXTINT0 as input before turning on the module, to prevent the module from entering into the standby mode unexpectedly. After that, customers can reset the GPIO as output to control the EXTINT0 pin. If the pin is unused, keep it open.

### 3.4.3. Backup Mode

Backup mode requires lower power consumption than standby mode. In this mode, the module stops acquiring and tracking satellites. UART is not accessible. But the backed-up memory in RTC domain which contains all the necessary GNSS information for quick start-up and a small amount of user configuration variables is alive. Due to the backed-up memory, EASY technology is available. The current consumption in this mode is about 7uA.

There are two ways to enter into backup mode and back to full on mode.

- Send "\$PMTK225,4\*2F" Command (the signal marked red line opens the switch in **Figure 3**) to enter into backup mode. The only way to wake up the module is pulling the FORCE\_ON pin high (the signal marked red line closes the switch in **Figure 3**).
- Cutting off VCC and keeping V\_BCKP powered will make the module enter into backup mode from full on mode. As long as the VCC pin is powered, the module will enter into full on mode immediately.

**NOTE**

Keep FORCE\_ON pin open or low before entering into backup mode. Or else, the backup mode will be unavailable.

For a better understanding, please refer to **Chapter 3.3** to see details about the internal power construction. The V\_BCKP pin can be directly provided by an external capacitor or battery (rechargeable or non-chargeable). Please refer to the following figure for RTC backup reference design.

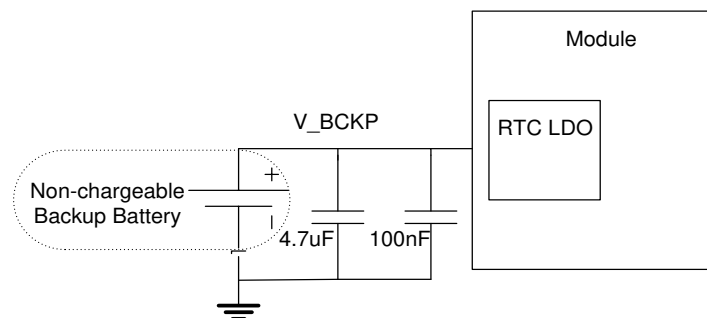

**Figure 4: RTC Supply from Non-chargeable Battery**

With a charging circuit, V\_BCKP will support battery charging function. Please see the reference charging circuit in the figure below.

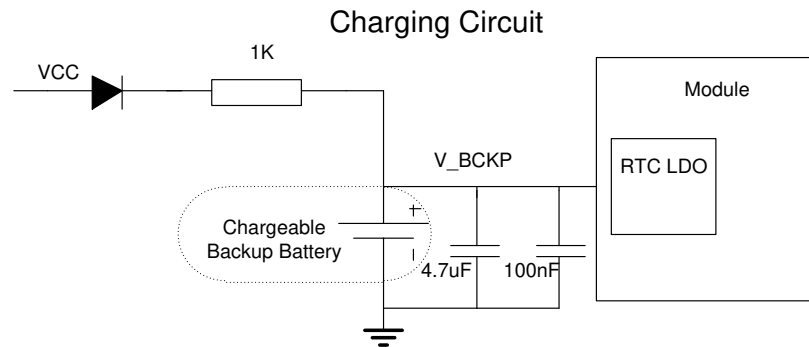

**Figure 5: Reference Charging Circuit for Rechargeable Batteries**

The coin-type rechargeable capacitor from Seiko (<http://www.sii.co.jp/en>) can be used as an alternative to the chargeable backup battery. And Schottky diode from ON Semiconductor (<http://www.onsemi.com>) is recommended to be the choice of diode for its low voltage drop.

### 3.4.4. Periodic Mode

Periodic mode can control the full on mode and standby/backup mode periodically to reduce power consumption. It contains periodic standby mode and periodic backup mode.

The format of the command, which enables the module to enter into periodic mode, is as following:

**Table 7: Format of the PMTK Command Enabling Periodic Mode**

Format:		
\$PMTK225,<Type>,<Run_time>,<Sleep_time>,<2nd_run_time>,<2nd_sleep_time>*<checksum><CR><LF>		
Parameter	Format	Description
Type	Decimal	<b>Type=1:</b> Periodic backup mode <b>Type=2:</b> Periodic standby mode
Run_time	Decimal	<b>Run_time=</b> Full on mode period (ms)
Sleep_time	Decimal	<b>Sleep_time=</b> Standby/Backup mode period (ms)
2nd_run_time	Decimal	<b>2nd_run_time=</b> Full on mode period (ms) for extended acquisition in case module's acquisition fails during the <b>Run_time</b>
2nd_sleep_time	Decimal	<b>2nd_sleep_time=</b> Standby/Backup mode period (ms) for

		extended sleep in case module's acquisition fails during the <b>Run_time</b>
<b>Checksum</b>	Hexadecimal	Hexadecimal checksum

### Example

```
$PMTK225,2,3000,12000,18000,72000*15<CR><LF>
$PMTK225,1,3000,12000,18000,72000*16<CR><LF>
```

In periodic standby mode, sending "\$PMTK225,0\*2B" in any time will make the module enter into full on mode.

In periodic backup mode, pulling the FORCE\_ON high and sending "\$PMTK225,0\*2B" immediately will make the module enter into full on mode.

While in periodic backup mode, sending "\$PMTK225,0\*2B" during the **Run\_time** or **2nd\_run\_time** will also make the module enter into full on mode. But this is hard to operate and thus is not recommended.

### NOTES

1. Considering the EXTINT0 pin is edge-triggered, it is recommended to set the GPIO of customers' MCU which controls EXTINT0 as input before turning on the module, to prevent the module from entering into the standby mode unexpectedly. After that, customer can reset the GPIO as output to control the EXTINT0 pin. If the pin is unused, keep it open.
2. Keep FORCE\_ON pin open or low before entering into periodic backup mode. Or else, the periodic backup mode will be unavailable.

The following figure has shown the operation mechanism of periodic mode. When customers send PMTK commands, the module will be in the full on mode first. Several minutes later, the module will enter into the periodic mode according to the setting of parameters. When the module fails to fix the position during **Run\_time**, the module will switch to **2nd\_run\_time** and **2nd\_sleep\_time** automatically. As long as the module fixes the position again successfully, the module will return to **Run\_time** and **Sleep\_time**.

Before entering into the periodic mode, please make sure the module is in tracking mode, otherwise the module may have a risk of failure in satellite tracking. If the module is located in weak signal areas, it is better to set a longer **2nd\_run\_time** to ensure the success of reacquisition.

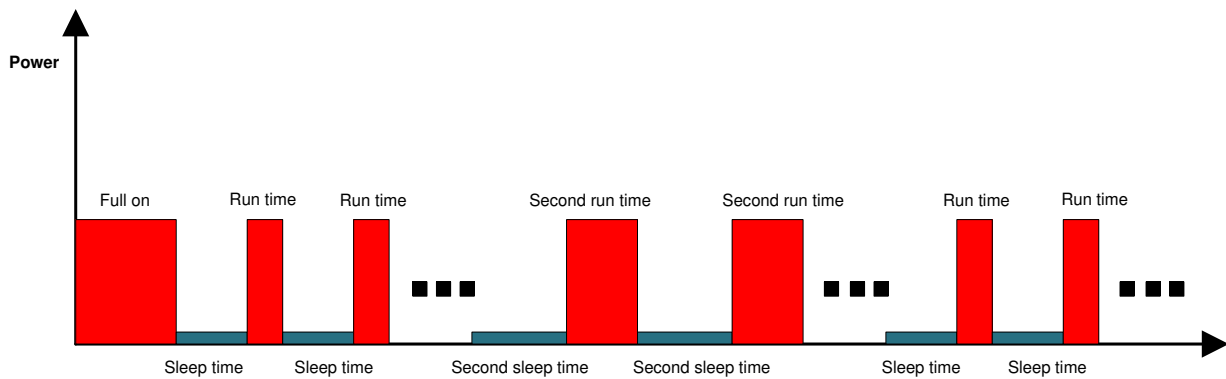

**Figure 6: Operation Mechanism of Periodic Mode**

The average current consumption in periodic mode can be calculated based on the following formula:

$$I_{\text{periodic}} = (I_{\text{tracking}} * T1 + I_{\text{standby/backup}} * T2) / (T1 + T2) \quad T1: \text{Run time}, T2: \text{Sleep time}$$

### Example

PMTK225,2,3000,12000,18000,72000\*15 for periodic mode with 3s in tracking mode and 12s in standby mode based on GPS&GLONASS. The average current consumption is calculated below:  
 $I_{\text{periodic}} = (I_{\text{tracking}} * T1 + I_{\text{standby}} * T2) / (T1 + T2) = (22\text{mA} * 3\text{s} + 0.5\text{mA} * 12\text{s}) / (3\text{s} + 12\text{s}) \approx 4.8(\text{mA})$

PMTK225,1,3000,12000,18000,72000\*16 for periodic mode with 3s in tracking mode and 12s in backup mode based on GPS&GLONASS. The average current consumption is calculated below:  
 $I_{\text{periodic}} = (I_{\text{tracking}} * T1 + I_{\text{backup}} * T2) / (T1 + T2) = (22\text{mA} * 3\text{s} + 0.007\text{mA} * 12\text{s}) / (3\text{s} + 12\text{s}) \approx 4.4(\text{mA})$

### 3.4.5. AlwaysLocate™ Mode

AlwaysLocate™ is an intelligent power saving mode. It contains AlwaysLocate™ backup mode and AlwaysLocate™ standby mode.

AlwaysLocate™ standby mode allows the module to switch automatically between full on mode and standby mode. According to the environmental and motion conditions, the module can adaptively adjust the full on time and the standby time to achieve the balance between positioning accuracy and power consumption. Sending "\$PMTK225,8\*23" Command and the module returning "\$PMTK001,225,3\*35" means that the module has entered AlwaysLocate™ standby mode successfully, which greatly saves power consumption. Sending "\$PMTK225,0\*2B" Command in any time will make the module back to full on mode.

AlwaysLocate™ backup mode is similar to AlwaysLocate™ standby mode. The difference is that the AlwaysLocate™ backup mode allows the module to switch automatically between full on mode and



backup mode. Sending “\$PMTK225,9\*22” Command will make the module enter into AlwaysLocate™ backup mode. Pulling FORCE\_ON high and sending “\$PMTK225,0\*2B” Command immediately will make the module back to full on mode.

The position accuracy in AlwaysLocate™ mode may degrade, especially in high speed movement. The following figure illustrates the power consumption of module in different scenarios.

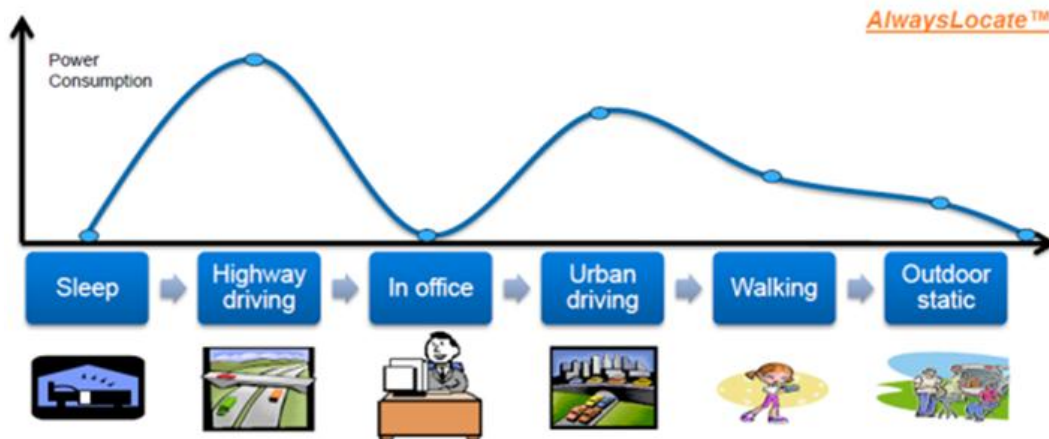

**Figure 7: Power Consumption in Different Scenarios (AlwaysLocate™ Mode)**

When located in outdoors and kept in static, the module which is equipped with an active antenna, has an average current consumption of approx. 2.7mA in AlwaysLocate™ standby mode and 2.6mA in AlwaysLocate™ backup mode based on GPS & GLONASS.

#### NOTES

1. Considering the EXTINT0 pin is edge-triggered, it is recommended to set the GPIO of customers' MCU which controls EXTINT0 as input before turning on the module, to prevent the module from entering into the standby mode unexpectedly. After that, customer can reset the GPIO as output to control the EXTINT0. If the pin is unused, keep it open.
2. Keep FORCE\_ON pin open or low before entering into AlwaysLocate™ backup mode. Or else, the AlwaysLocate™ backup mode will be unavailable.

#### 3.4.6. GLP Mode

GLP (GNSS low power) mode is an optimized solution for wearable fitness and tracking devices. It can reduce power consumption by closing high accuracy positioning.

In GLP mode, the module can provide good positioning performance in walking and running scenarios, and supports automatic dynamic duty operation switch for a balance on performance and power consumption. It will come back to normal mode in harsh environments to keep good accuracy, thus realizing maximum performance with the lowest power consumption.

The average current consumption in GLP mode is down to 8.8mA in static scenario, which is only 40% of that in normal mode. It may increase a little bit in dynamic scenario. The average current consumption in different outdoor scenarios in GLP mode and normal mode is shown in the table below.

**Table 8: Average Current Consumption in GLP Mode and Normal Mode**

Scenario	In GLP Mode (mA)	In Normal Mode (mA)
Static	8.8	22
Walking	9.6	24
Running	11.6	29
Driving	12.8	32

Customers can use the following commands to make the module enter into or exit from the GLP mode:

- \$PQGLP,W,1,1\*21: The command is used to set the module into GLP mode. When "\$PQGLP,W,OK\*09" is returned, it means the module has entered into GLP mode successfully.
- \$PQGLP,W,0,1\*20: The command is used to make the module exit from GLP mode. When "\$PQGLP,W,OK\*09" is returned, it means the module has exited from GLP mode successfully.

#### NOTES

1. It is recommended to set all the necessary commands before the module enters into GLP mode. If customers need to send commands, please exit from GLP mode first.
2. When the module enters into GLP mode, 1PPS function will be disabled.
3. When the GLP mode is enabled, the SBAS will be affected.
4. In high dynamic scenario, the module will slightly decrease positioning accuracy in GLP mode.
5. The modules will automatically return to the normal mode in complex environments to keep good positioning accuracy.

### 3.5. Reset

L96 module can be restarted by driving the RESET to a low level voltage for at least 10ms and then releasing it. Please note that the resetting will possibly force the loss of volatile RAM data, while non-volatile backup RAM content is not cleared so that fast TTFF is still possible. An OC driver circuit shown as below is recommended to control the RESET.

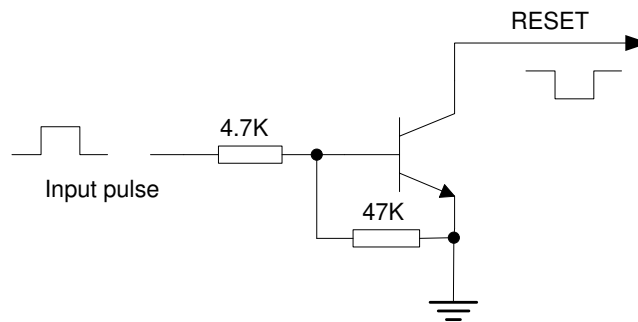

**Figure 8: Reference OC Circuit for Module Reset**

The following figure shows the reset timing of L96 module.

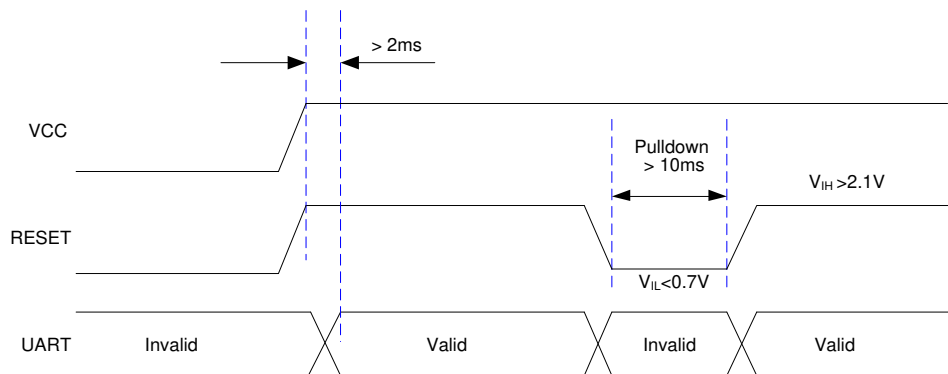

**Figure 9: Module Reset Timing**

### 3.6. UART Interface

The module provides one universal asynchronous receiver & transmitter serial port. The module is designed as DCE (Data Communication Equipment), following the traditional DCE-DTE (Data Terminal Equipment) connection. The module and the client (DTE) are connected through the signal shown in the following figure. It supports data baud rate from 4800bps to 115200bps, 9600bps by default.

UART port:

- TXD1: Send data to the RXD signal line of DTE
- RXD1: Receive data from the TXD signal line of DTE

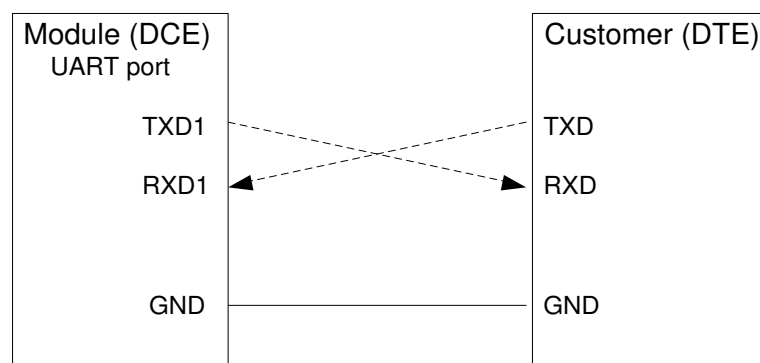
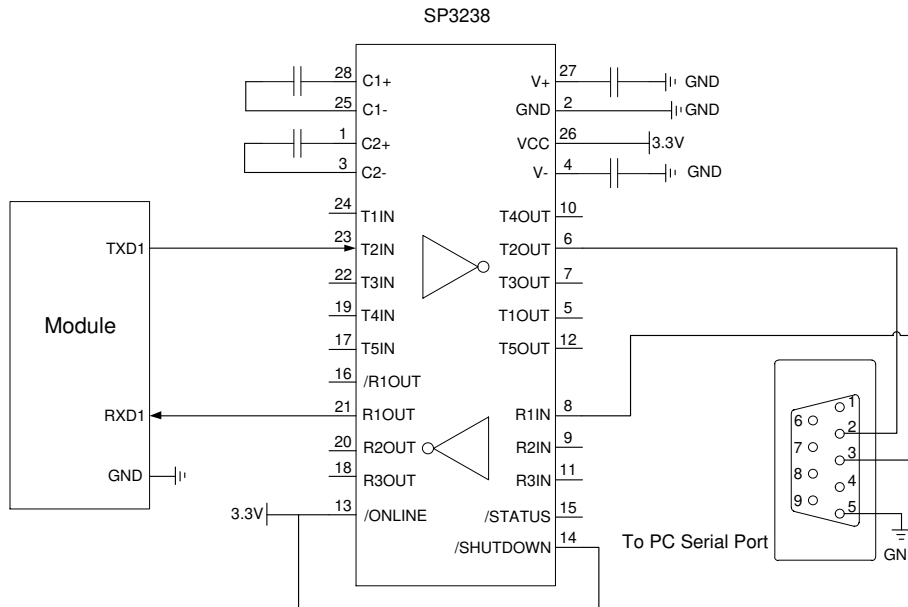

**Figure 10: Reference Design for UART Port**

This UART port has the following features:

- UART port can be used for NMEA output, PMTK/PQ command input and firmware upgrade.
- The default output NMEA type setting is RMC, VTG, GGA, GSA, GSV and GLL.
- UART port supports the following data rates: 4800bps, 9600bps, 14400bps, 19200bps, 38400bps, 57600bps and 115200bps. The default setting is 9600bps, 8 bits, no parity bit, 1 stop bit.
- Hardware flow control and synchronous operation are not supported.

The UART port does not support the RS-232 level but only CMOS level. If the module's UART port is connected to the UART port of a computer, it is necessary to add a level shift circuit between the module and the computer. Please refer to the following figure.



**Figure 11: RS-232 Level Shift Circuit**

**NOTE**

GNSS modules output more data than single GPS systems. The default baud rate (9600bps) of L96 is enough to transmit GNSS NMEA. If the baud rate has to be set to 4800bps, then it is recommended to decrease NMEA output types so as to avoid possible data loss.

### 3.7. I2C Interface

L96 module provides one I2C interface. The interface outputs NMEA data by default when reading. It can also receive PMTK/PQ commands via I2C bus.

The I2C interface has the following features:

- Support fast mode, with bit rate up to 400kbps.
- Support 7-bit address.
- Work on slave mode.
- Default I2C address values are Write: 0x20, Read: 0x21.

For more details, please refer to **document [5]**.

The following circuit is an example of connection.

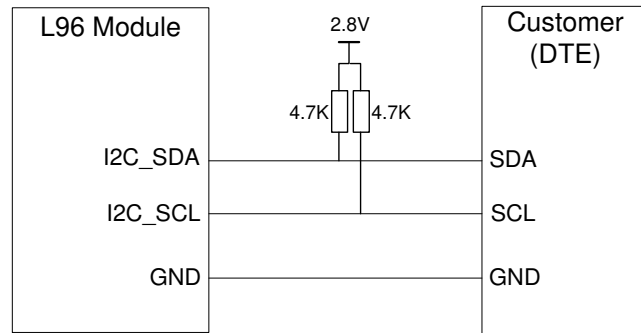

**Figure 12: Reference Design for I2C Interface**

### NOTES

1. I2C\_SDA/I2C\_SCL should be externally pulled up to 2.8V.
2. The voltage threshold of I2C is 2.8V. If the system voltage is not consistent with it, a level shifter circuit must be used.
3. I2C interface is supported only on firmware versions ended with "SC". In other firmware versions, I2C\_SDA and I2C\_SCL pins are used for RTCM data output. When I2C interface is supported, NEMA data should be outputted via I2C interface rather than UART interface, otherwise there maybe NEMA data loss.

## 3.8. 3D\_FIX Interface

The 3D\_FIX is assigned as a fix flag output. The pin will output a high voltage level to indicate successful positioning.

## 3.9. JAM\_IND Interface

L96 module provides a jamming detection indicator to detect whether there are any jammers that may have impact on the module. If there is any jammer, the JAM\_DET pin will output a low level; otherwise it outputs a high voltage level.

### 3.10. GEO\_FENCE Interface

L96 module provides a GEO\_FENCE interface to enable geo-fence boundary indication.

The module can be configured to report URCs to indicate entering or exiting the geo-fence. And the following four URC report modes are supported:

- 0: Do not report URC when entering or exiting the geo-fence (default setting)
- 1: Report URC when entering the geo-fence
- 2: Report URC when exiting the geo-fence
- 3: Report URC when entering or exiting the geo-fence

By default, the mode is 0, in which case the module will not report any URC to indicate entering or exiting the geo-fence, and GEO\_FENCE interface always keeps high. In other modes, the voltage level status of GEO\_FENCE is illustrated in the table below. For more details, please refer to **document [6]**.

**Table 9: GEO\_FENCE Voltage Level Status in Different URC Report Modes**

URC Mode	Voltage Level Status
0	HIGH
1	HIGH to LOW when entering the geo-fence, and then from LOW to HIGH when the module exits the geo-fence again
2	HIGH to LOW when exiting the geo-fence, and then from LOW to HIGH when the module enters the geo-fence again
3	HIGH

### 3.11. EASY Autonomous AGPS Technology

L96 supports EASY technology to supply aiding information like ephemeris, almanac, rough last position, time and satellite status in order to improve the acquisition sensitivity and the TTFF of the module.

EASY technology works as embedded software which can accelerate TTFF by predicting satellite navigation messages from received ephemerides. L96 will calculate and predict orbit information automatically up to 3 days after first receiving the broadcast ephemeris, and save the predicted information into the internal memory. When there is no adequate information received from satellites, the module will use the information saved in the internal memory for positioning, thus the technology is helpful for positioning and TTFF improvement.

The EASY function can reduce TTFF to 5s in warm start. In this case, GNSS's backup domain should be valid. In order to gain enough broadcast ephemeris information from GNSS satellites; the module should receive the information for at least 5 minutes in good signal conditions after it fixes the position.

EASY function is enabled by default. "\$PMTK869,1,0\*34" Command can be used to disable EASY function. For more details, please refer to **document [2]**.

### 3.12. EPO Offline AGPS Technology

L96 module features a function called EPO (Extended Prediction Orbit), a world leading technology that supports 30-day orbit predictions. Occasional download from the EPO server is needed. For more details, please refer to **document [4]**.

### 3.13. Multi-tone AIC

L96 module supports a function called multi-tone AIC (Active Interference Cancellation) to decrease harmonic of RF noise from Wi-Fi, Bluetooth, GSM and 3G.

The AIC function can detect 12 different single-tone interference signal and then track the phase and frequency of these 12 interference signals to provide continuous cancellation. AIC function is enabled by default. Enabling AIC function will increase current consumption by about 1mA @VCC=3.3V. The following commands can be used to set AIC function.

Enable AIC function: "\$PMTK 286,1\*23".

Disable AIC function: "\$PMTK 286,0\*22".

### 3.14. ANTON

L96 module provides a pin called ANTON which is related to module operation modes. Its voltage level will change in different module operation modes. When the module works in full on mode, this pin is in high level. While working in standby mode, backup mode, AlwaysLocate™ mode, or during sleep time in periodic mode, this pin is in low level. Based on this characteristic, the ANTON pin can be used to control the power supply of active antenna or the enable pin of the external LNA to reduce power consumption. Please refer to **Chapter 3.2** for more electrical characteristics about this pin. There is an example of this pin's application described in **Chapter 4.2**.



### 3.15. LOCUS

L96 module supports the embedded logger function called LOCUS. When enabled by “\$PMTK185,0\*22” Command, the function allows the module to log GNSS data to internal flash memory automatically without the need to wake up the host, and thus, the module can enter into sleep mode to save power consumption, and does not need to receive NMEA information all the time. L96 provides a log capacity of more than 16 hours.

The detailed procedures of this function are illustrated below:

- The module has fixed the position (only effective in 3D\_fixed scenario).
- Sending “\$PMTK184,1\*22” Command to erase internal flash.
- Sending “\$PMTK185,0\*22” Command to start logging.
- The module logs the basic information (UTC time, latitude, longitude and height) every 15s to internal flash memory.
- Stop logging the information by sending “\$PMTK185,1\*23” Command.
- MCU can get the data via UART by sending “\$PMTK622,1\*29” Command to the module.

“\$PMTK183\*38” Command can be used to query the state of LOCUS.

The raw data which MCU gets has to be parsed via LOCUS parser code provided by Quectel. For more details, please contact Quectel Technical Support Team.

### 3.16. PPS VS. NMEA

Pulse per Second (PPS) VS. NMEA can be used for time service. The latency range of the beginning of UART Tx is between 465ms and 485ms, and after the rising edge of PPS.

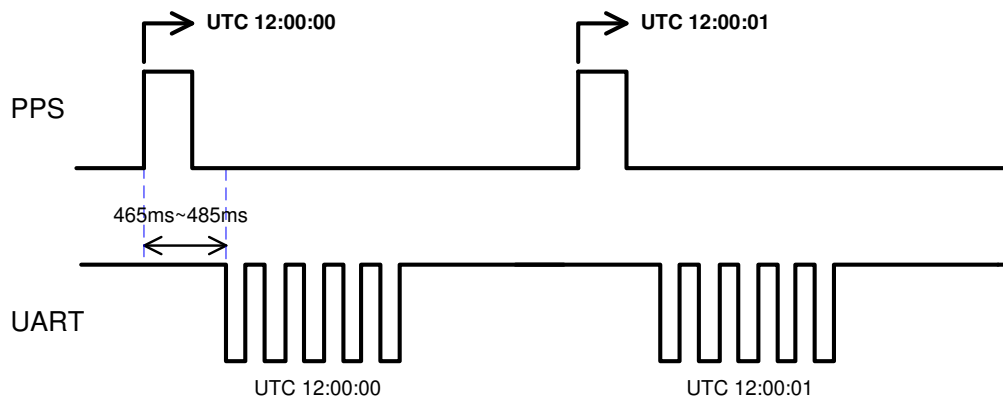

**Figure 13: PPS VS. NMEA Timing**

The feature only supports 1Hz NMEA output and baud rate at 14400bps~115200bps. When the baud rate is 9600bps, it only supports RMC NMEA sentence output. Because at low baud rates, the quantity of NMEA sentences may be too large to be transmitted. Customers can enable this function by sending "\$PMTK255,1\*2D", and disable the function by sending "\$PMTK255,0\*2C".

# 4 Antenna Interfaces

L96 module supports GPS/GLONASS/Galileo/BeiDou systems. The RF signal is obtained from the RF\_IN pin. The impedance of RF trace should be controlled as 50Ω, and the trace length should be kept as short as possible.

## 4.1. Antenna Specifications

The L96 module can be connected to a dedicated GPS/GLONASS/Galileo/BeiDou passive or active antenna to receive GPS/GLONASS/Galileo/BeiDou satellite signals. The recommended antenna specifications are given in the following table.

**Table 10: Recommended Antenna Specifications**

Antenna Type	Specification
GNSS	Frequency range: 1559MHz~1609MHz Polarization: RHCP or Linear VSWR: <2 (Typ.) Passive antenna gain: >0dBi Active antenna noise figure: <1.5dB Active antenna gain: >0dBi Active antenna embedded LNA gain: <17dB

## 4.2. Recommended Circuits for Antenna

Both active and passive antennas can be used for L96 module.

## 4.2.1. Active Antenna Reference Designs

### 4.2.1.1. Reference Design of Active Antenna without ANTON

The following figure is a typical reference design for active antenna without ANTON. In this mode, the antenna is powered by the VCC\_3V3.

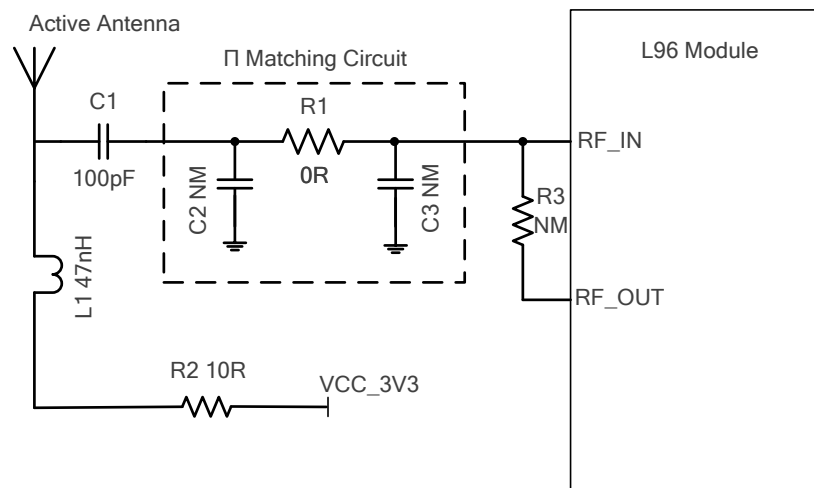

**Figure 14: Reference Design for Active Antenna without ANTON**

C2, C3 and R1 are reserved matching circuits for antenna impedance modification. By default, R1 is 0Ω, C1 is 100pF, while C2, C3 and R3 are not mounted.

L96 module needs 3.3V voltage which can be provided by an external LDO.

The inductor L1 is used to prevent the RF signal from leaking into the VCC\_3V3 and route the bias supply to the active antenna. The recommended value of L1 is no less than 47nH. R2 can protect the whole circuit in case the active antenna is short-circuited to ground.

### 4.2.1.2. Reference Design of Active Antenna with ANTON

L96 module can also reduce power consumption by controlling the power supply of active antenna through the pin of ANTON.

A reference circuit for active antenna with ANTON is given as below.

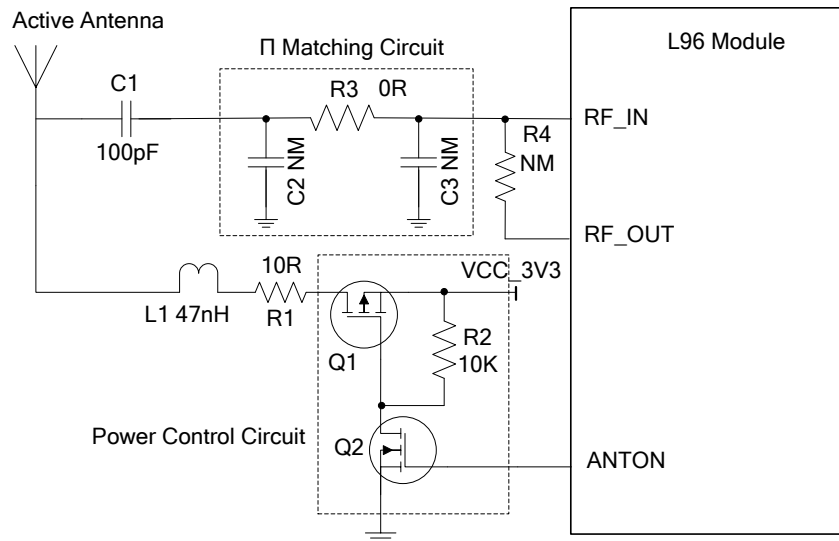

**Figure 15: Reference Design for Active Antenna with ANTON**

C2, C3 and R3 are reserved matching circuits for antenna impedance modification. By default, R3 is 0 $\Omega$ , C1 is 100pF, while C2, C3 and R4 are not mounted.

ANTON is an optional pin which can be used to control the power supply of the active antenna. When the ANTON pin is pulled down, MOSFET Q1 and Q2 are in high impedance state and the power supply for antenna is cut off. When ANTON is pulled high, it will make Q1 and Q2 in the on-state, and VCC\_3V3 will provide power supply for the active antenna. The high or low level of ANTON pin is determined by the module's state. Please refer to **Chapter 3.14** for more details. If unused, please keep ANTON pin open.

To minimize the current consumption, the value of R2 should not be too small, and the recommended value is 10K $\Omega$ .

## 4.2.2. Passive Antenna Reference Designs

### 4.2.2.1. Reference Design of Passive Antenna without External LNA

The following figure is a typical reference design for passive antenna without LNA.

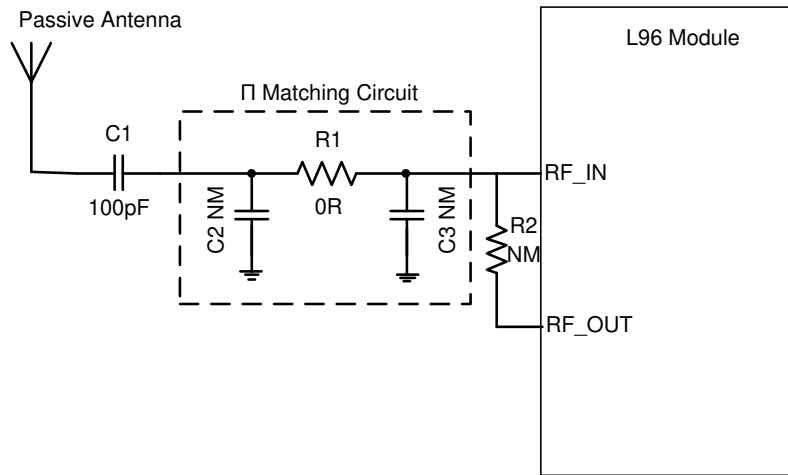
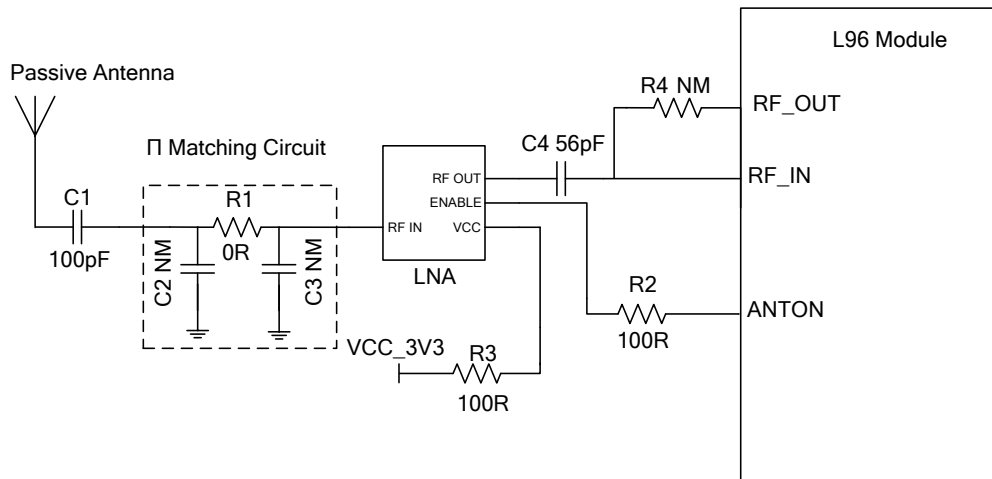

**Figure 16: Reference Design for Passive Antenna without LNA**

C2, C3 and R1 are reserved matching circuits for antenna impedance modification. R1 is 0Ω, C1 is 100pF, while C2, C3 and R2 are not mounted by default. Impedance of RF trace should be controlled as 50Ω and the trace length should be kept as short as possible.

#### 4.2.2.2. Reference Design of Passive Antenna with External LNA

In order to improve the receiver sensitivity and reduce the TFF, an external LNA between the passive antenna and the L96 module is recommended. A reference design is shown as below.



**Figure 17: Reference Design for Passive Antenna with LNA**

C2, C3 and R1 form a reserved matching circuit for passive antenna and LNA. R1 is 0Ω, C1 is 100pF, while C2, C3 and R4 are not mounted by default. C3 is reserved for impedance matching between the LNA and the L96 module and the default value of C4 capacitor is 56pF which can be further optimized

according to the real conditions. ANTON is an optional pin which can be used to control the enable pin of an external LNA.

#### NOTES

1. The selected LNA should support GPS/GLONASS/Galileo/BeiDou systems. LNA from Maxim (<http://para.maximintegrated.com>) or from Infineon (<http://www.infineon.com>) is recommended to be used here. For more details about the external LNA circuit design, please refer to **document [3]** or contact Quectel Technical Support Team.
2. The power consumption of the module will be reduced by controlling LNA's enable pin through the ANTON pin of L96 module. If ANTON function is not used, please connect the enable pin of LNA to VCC and keep LNA always on.

### 4.2.3. Internal Antenna

The following figure is a typical reference design for internal antenna.

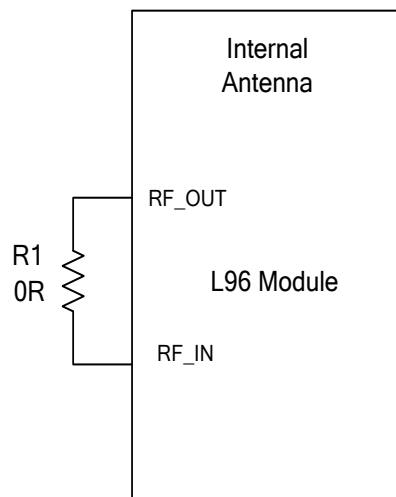

**Figure 18: Reference Design for Internal Antenna**

Matching circuits are not needed. Only R1 is needed and R1 is 0Ω. Also, the connection line between the two pins should be as short as possible.

### 4.3. PCB Layout Suggestion

L96 module is intended to be placed at the center of the top edge of the motherboard, and the distance between the edge of the module and the nearest ground plane edge should be kept for at least 10mm. The performance of the embedded antenna depends on the design of the ground plane on the motherboard. The optimum size of the ground plane is 80mm × 40mm, but a larger or smaller ground plane can also be used. The suggested minimum size of ground plane is 45mm × 20mm. Although the suggested minimum width of ground plane is 45mm, to maximize performance, it is recommended to extend the width as much as possible. Conversely, increasing the height of the ground plane to more than 20mm has no much effect on antenna performance.

A keepout area (4.8mm × 7.3mm) should be designed for the patch antenna of L96. Placement of any component is not allowed under the keepout area.

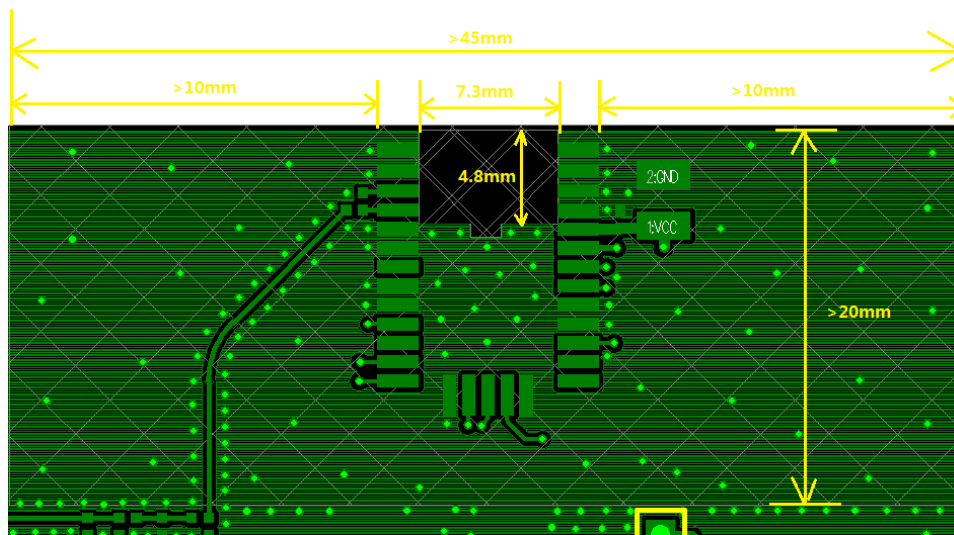

**Figure 19: PCB Layout**



# 5 Electrical, Reliability and Radio Characteristics

## 5.1. Absolute Maximum Ratings

Absolute maximum rating for power supply and voltage on digital pins of the module are listed in following table.

**Table 11: Absolute Maximum Ratings**

Parameter	Min.	Max.	Unit
Power Supply Voltage (VCC)	-0.3	4.5	V
Backup Battery Voltage (V_BCKP)	-0.3	4.5	V
Input Voltage at Digital Pins	-0.3	3.6	V
Input Power at RF_IN (P <sub>RF_IN</sub> )	-154	15	dBm

### NOTE

Stressing the module beyond the “Absolute Maximum Ratings” may cause permanent damage. The product is not protected against over-voltage or reversed voltage. Thus, it is necessary to utilize appropriate protection diodes to keep voltage spikes within the parameters given in the table above.

## 5.2. Operating Conditions

**Table 12: Power Supply Ratings**

Parameter	Description	Conditions	Min.	Type.	Max.	Unit
VCC	Supply voltage	The actual input voltages must stay between the minimum and maximum values.	2.8	3.3	4.3	V
I <sub>VCCP</sub>	Peak supply current	VCC=3.3V			150	mA
V_BCKP	Backup voltage supply		1.5	3.3	4.5	V
T <sub>OPR</sub>	Operating temperature range in full on mode		-40	25	85	°C

### NOTES

1. The figures in the table above can be used to determine the maximum current capability of power supply.
2. Operation beyond the "Operating Conditions" is not recommended and extended exposure beyond the "Operating Conditions" may affect the reliability of L96.

## 5.3. Current Consumption

The values of current consumption are shown in the following table.

**Table 13: Current Consumption**

Module	Conditions	Acquisition @3.3V	Tracking @3.3V	Standby @3.3V	Backup @V_BCKP=3.3V
L96	@-130dBm GPS	22mA	19mA	0.45mA	7uA
	@-130dBm GPS+GLONASS	25mA	22mA		

**NOTE**

The tracking current is tested in the following conditions:

- In Cold Start, 10 minutes after First Fix.
- In Hot Start, 15 seconds after First Fix.

## 5.4. Reliability Tests

**Table 14: Reliability Tests**

Test Item	Conditions	Standard
Thermal Shock	-30°C+80°C, 144 cycles	GB/T 2423.22-2002 Test Na IEC 68-2-14 Na
Damp Heat, Cyclic	+55°C; >90% Rh 6 cycles for 144 hours	IEC 68-2-30 Db Test
Vibration Shock	5Hz~20Hz, 0.96m <sup>2</sup> /s <sup>3</sup> ; 20Hz~500Hz, 0.96m <sup>2</sup> /s <sup>3</sup> -3dB/oct, 1 hour/axis; no function	2423.13-1997 Test Fdb IEC 68-2-36 Fdb Test
Heat Test	+85°C, 2 hours, operational	GB/T 2423.1-2001 Ab IEC 68-2-1 Test
Cold Test	-40°C, 2 hours, operational	GB/T 2423.1-2001 Ab IEC 68-2-1 Test
Heat Soak	+90°C, 72 hours, non-operational	GB/T 2423.2-2001 Bb IEC 68-2-2 Test B
Cold Soak	-45°C, 72 hours, non-operational	GB/T 2423.1-2001 A IEC 68-2-1 Test

## 5.5. ESD Protection

L96 GNSS module is an ESD sensitive device. ESD protection precautions should be emphasized. Proper ESD handling and packaging procedures must be applied throughout the processing, handling and operation of any application that incorporates the module.

Please note the following measures are good for ESD protection when L96 module is handled.

- The first contact point shall always be between the local GND and PCB GND when handling the PCB, unless there is a galvanic coupling between the local GND and the PCB GND.
- While mounting the module onto a motherboard, please make sure the GND is connected first, and

then the RF\_IN pad.

- Do not contact any charged capacitors or materials which may easily generate or store charges (such as patch antenna, coaxial cable, soldering iron, etc.) when handling the RF\_IN pad.
- To prevent electrostatic discharge from the RF input, please do not touch any exposed area of the mounted patch antenna.
- Make sure to use an ESD safe soldering iron (tip) when soldering the RF\_IN pin.

# 6 Mechanical Dimensions

This chapter describes the mechanical dimensions of the module. All dimensions are measured in millimeter (mm). The tolerances for dimensions without tolerance values are  $\pm 0.05\text{mm}$ .

## 6.1. Top and Side Dimensions of the Module

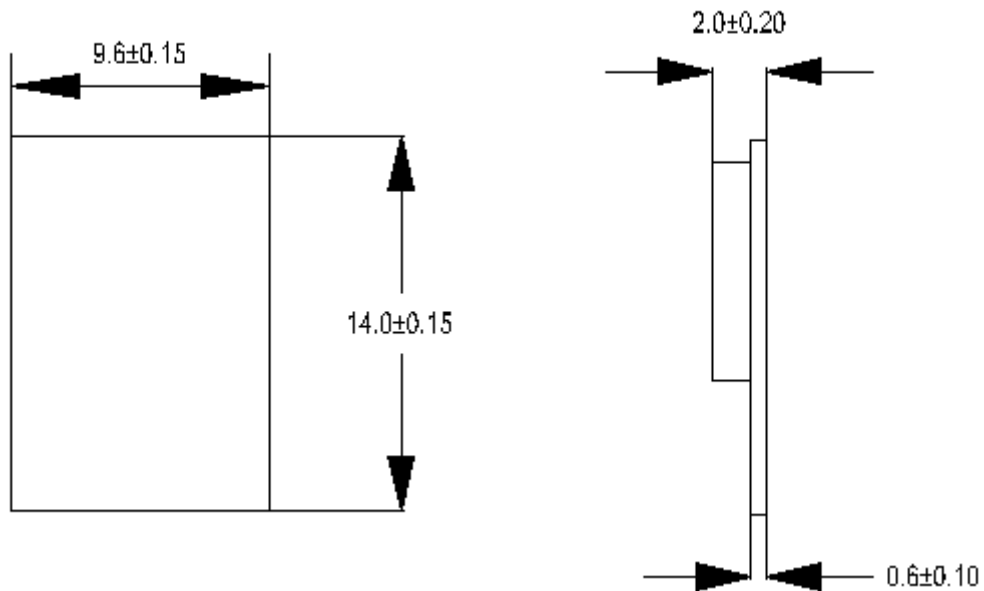

Figure 20: Top and Side Dimensions

## 6.2. Bottom Dimensions and Recommended Footprint

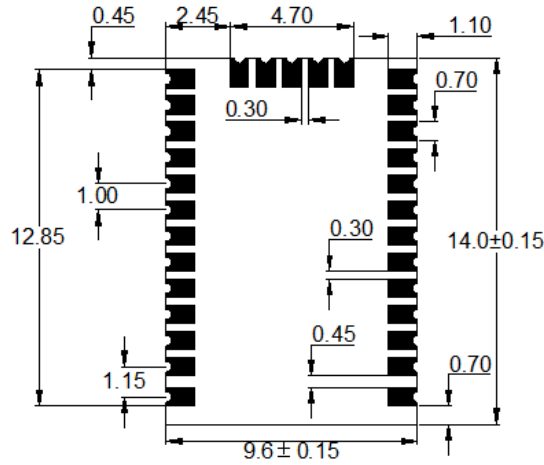

Figure 21: Bottom Dimensions

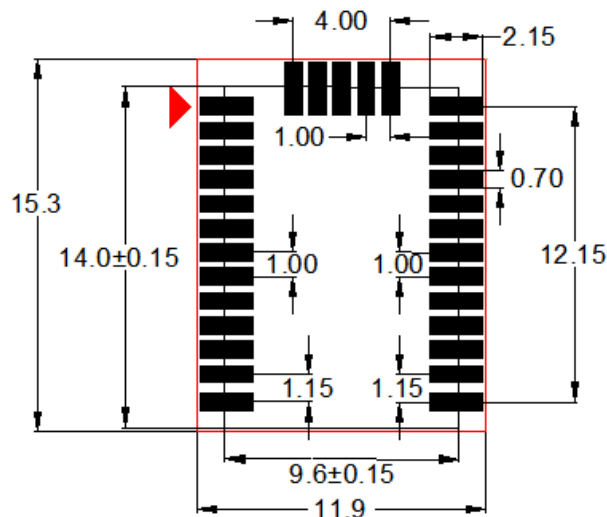

Figure 22: Recommended Footprint

### NOTE

For easy maintenance of this module and accessing to these pads, please keep a distance of no less than 3mm between the module and other components in host board.

### 6.3. Top and Bottom Views of the Module



Figure 23: Top View of the Module

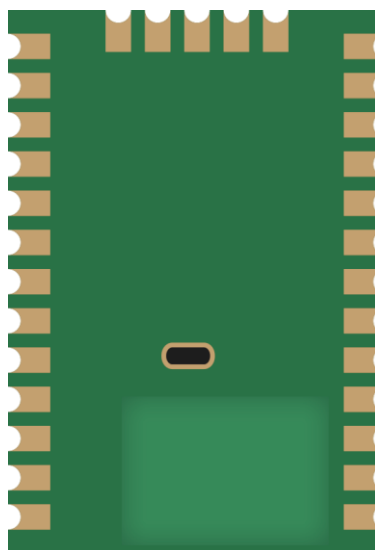

Figure 24: Bottom View of the Module

**NOTE**

These are design effect drawings of L96 module. For authentic dimension and appearance, please refer to the module that you receive from Quectel.

# 7 Storage, Manufacturing and Packaging

## 7.1. Storage

L96 is stored in a vacuum-sealed bag. It is rated at MSL 3, and its storage restrictions are shown as below.

1. Shelf life in the vacuum-sealed bag: 12 months at <math><40^{\circ}\text{C}/90\%\text{RH}</math>.
2. After the vacuum-sealed bag is opened, devices that will be subjected to reflow soldering or other high temperature processes must be:
  - Mounted within 168 hours at the factory environment of  $\leq 30^{\circ}\text{C}/60\%\text{RH}$ .
  - Stored at  $<10\%\text{RH}$ .
3. Devices require baking before mounting, if any circumstance below occurs.
  - When the ambient temperature is  $23^{\circ}\text{C}\pm 5^{\circ}\text{C}$  and the humidity indication card shows the humidity is  $>10\%$  before opening the vacuum-sealed bag.
  - Device mounting cannot be finished within 168 hours at factory conditions of  $\leq 30^{\circ}\text{C}/60\%\text{RH}$ .
4. If baking is required, devices may be baked for 8 hours at  $120^{\circ}\text{C}\pm 5^{\circ}\text{C}$ .

### NOTE

As the plastic package cannot be subjected to high temperature, it should be removed from devices before high temperature ( $120^{\circ}\text{C}$ ) baking. If shorter baking time is desired, please refer to *IPC/JEDECJ-STD-033* for baking procedure.

## 7.2. Manufacturing and Soldering

Push the squeegee to apply the solder paste on the surface of stencil, thus making the paste fill the stencil openings and then penetrate to the PCB. The force on the squeegee should be adjusted properly



so as to produce a clean stencil surface on a single pass. To ensure the module soldering quality, the thickness of stencil for the module is recommended to be 0.13mm. For more details, please refer to **document [7]**.

It is suggested that the peak reflow temperature is 240°C~245°C, and the absolute maximum reflow temperature is 245°C. To avoid damage to the module caused by repeated heating, it is strongly recommended that the module should be mounted after reflow soldering for the other side of PCB has been completed. The recommended reflow soldering thermal profile (lead-free reflow soldering) and related parameters are shown below.

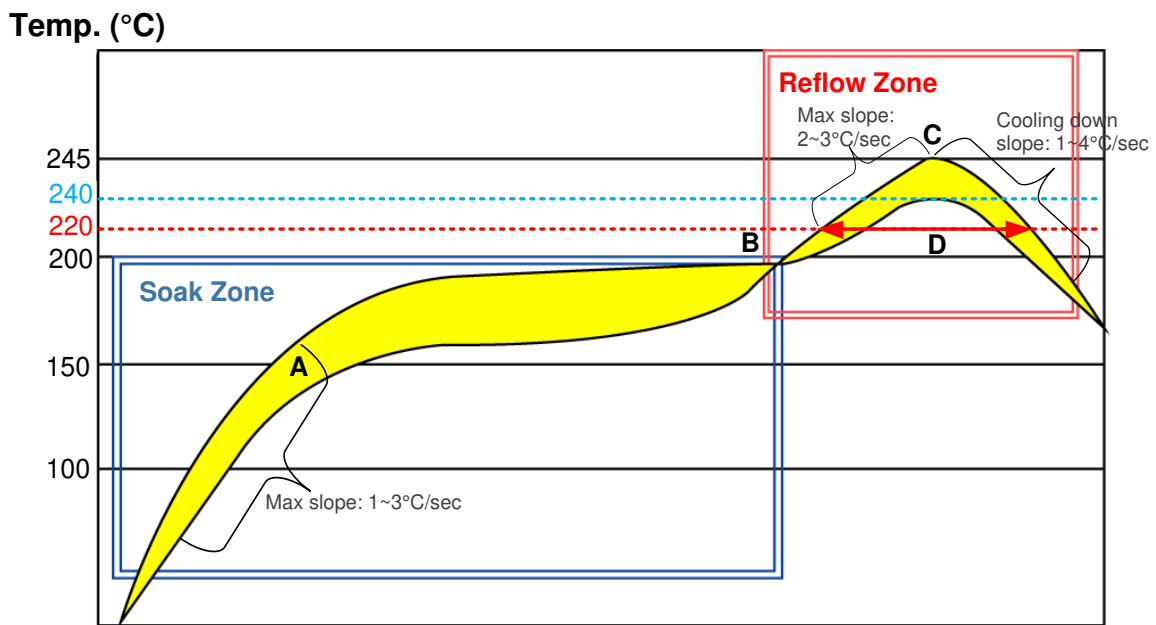

**Figure 25: Recommended Reflow Soldering Thermal Profile**

**Table 15: Recommended Thermal Profile Parameters**

Factor	Recommendation
<b>Soak Zone</b>	
Max slope	1 to 3°C/sec
Soak time (between A and B: 150°C and 200°C)	60 sec to 120 sec
<b>Reflow Zone</b>	
Max slope	2 to 3°C/sec
Reflow time (D: over 220°C)	40 sec to 60 sec

Max temperature 240°C ~ 245°C

Cooling down slope 1 to 4°C/sec

**Reflow Cycle**

Max reflow cycle 1

**NOTES**

1. During manufacturing and soldering, or any other processes that may contact the module directly, NEVER wipe the module's shielding can with organic solvents, such as acetone, ethyl alcohol, isopropyl alcohol, trichloroethylene, etc. Otherwise, the shielding can may become rusted.
2. The shielding can for the module is made of Cupro-Nickel base material. It is tested that after 12 hours' Neutral Salt Spray test, the laser engraved label information on the shielding can is still clearly identifiable and the QR code is still readable, although white rust may be found.

**7.3. Tape and Reel Packaging**

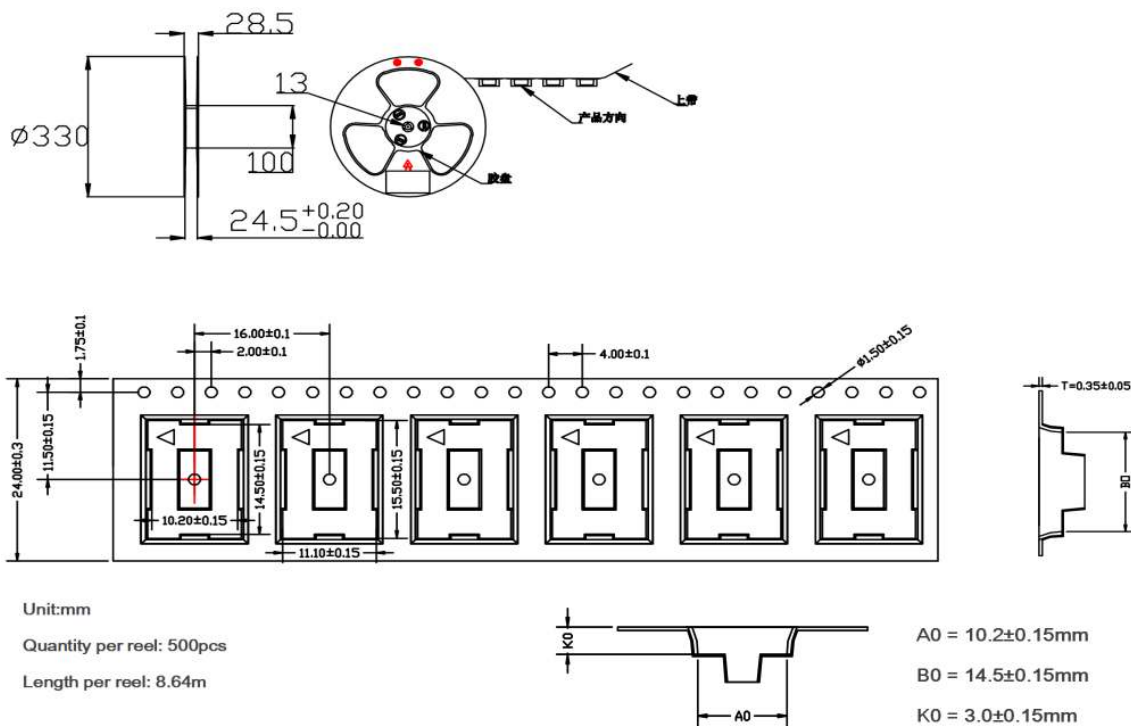

**Figure 26: Tape and Reel Specifications**

**Table 16: Reel Packaging**

Model Name	MOQ for MP	Minimum Package: 500pcs	Minimum Package x 4 = 2000pcs
L96	500pcs	Size: 370mm × 350mm × 40mm N.W: 0.24kg G.W: 0.83kg	Size: 380mm × 250mm × 365mm N.W: 0.95kg G.W: (3.85±0.1)kg

# 8 Appendix A References

**Table 17: Related Documents**

SN	Document Name	Remark
[1]	Quectel_L96_EVB_User_Guide	L96 EVB User Guide
[2]	Quectel_L96_GNSS_Protocol_Specification	L96 GNSS Protocol Specification
[3]	Quectel_L96_Reference_Design	L96 Reference Design
[4]	Quectel_GNSS_EPO_Application_Note	GNSS EPO Application Note
[5]	Quectel_GNSS_I2C_Application_Note	GNSS I2C Application Note
[6]	Quectel_GNSS_SDK_Commands_Manual	GNSS SDK Commands Manual
[7]	Quectel_Module_Secondary_SMT_User_Guide	Module Secondary SMT User Guide

**Table 18: Terms and Abbreviations**

Abbreviation	Description
AGPS	Assisted GPS
AIC	Active Interference Cancellation
CEP	Circular Error Probable
DGPS	Differential GPS
EASY	Embedded Assist System
EGNOS	European Geostationary Navigation Overlay Service
EMC	Electromagnetic Compatibility
EPO	Extended Prediction Orbit
ESD	Electrostatic Discharge

GLONASS	Global Navigation Satellite System (the Russian GNSS)
GNSS	Global Navigation Satellite System
GPS	Global Positioning System
HDOP	Horizontal Dilution of Precision
IC	Integrated Circuit
I/O	Input/Output
Kbps	Kilo Bits Per Second
LNA	Low Noise Amplifier
MSAS	Multi-Functional Satellite Augmentation System
MOQ	Minimum Order Quantity
NMEA	National Marine Electronics Association
PDOP	Position Dilution of Precision
PMTK	MTK Proprietary Protocol
PPS	Pulse Per Second
PQ	Quectel Proprietary Protocol
PRN	Pseudo Random Noise Code
QZSS	Quasi-Zenith Satellite System
RHCP	Right Hand Circular Polarization
RMC	Recommended Minimum Specific GNSS Data
RTCM	Radio Technical Commission for Maritime Services
SAW	Surface Acoustic Wave
SBAS	Satellite-based Augmentation System
TTFF	Time To First Fix
UART	Universal Asynchronous Receiver & Transmitter
VDOP	Vertical Dilution of Precision
VTG	Course over Ground and Ground Speed, Horizontal Course and Horizontal Velocity

---

WAAS	Wide Area Augmentation System
Inom	Nominal Current
I <sub>max</sub>	Maximum Load Current
V <sub>max</sub>	Maximum Voltage Value
V <sub>nom</sub>	Nominal Voltage Value
V <sub>min</sub>	Minimum Voltage Value
V <sub>IHmax</sub>	Maximum Input High Level Voltage Value
V <sub>IHmin</sub>	Minimum Input High Level Voltage Value
V <sub>ILmax</sub>	Maximum Input Low Level Voltage Value
V <sub>ILmin</sub>	Minimum Input Low Level Voltage Value
V <sub>Imax</sub>	Absolute Maximum Input Voltage Value
V <sub>Imin</sub>	Absolute Minimum Input Voltage Value
V <sub>OHmax</sub>	Maximum Output High Level Voltage Value
V <sub>OHmin</sub>	Minimum Output High Level Voltage Value
V <sub>OLmax</sub>	Maximum Output Low Level Voltage Value
V <sub>OLmin</sub>	Minimum Output Low Level Voltage Value

---