

# SAS4xNN Series

## Pin-Compatible SAS/SATA Expander Series Featuring SAS-4 Technology

### Broadcom Storage

Broadcom products serve four primary target markets: wireless communications, wired infrastructure, enterprise storage, and industrial. Broadcom offers the industry's broadest portfolio of storage solutions, backed by decades of experience and trusted by the world's leading server and storage suppliers. Broadcom provides the building blocks for storage solutions that help customers understand, prioritize, store, and protect critical data. The Broadcom storage products portfolio includes MegaRAID® controller cards, Host Bus Adapters (HBAs), Advanced Software Options, and SAS storage ICs, including RAID-on-Chip (ROCs), I/O controllers, and expanders.

### Overview

The SAS4xNN Serial Attached SCSI (SAS) expanders provide the ability to seamlessly connect systems and drives to meet the continuing demand for storage and enhanced performance. Representing the ninth generation of SAS expanders, the SAS4xNN line couples SAS-4 technology with Broadcom's industry-hardened hardware and firmware architecture to offer 24, 32, 40, and 48 ports of connectivity for 6G, 12G, 24G SAS, and 6Gb/s SATA storage end-devices. The pin-compatible series doubles the effective bandwidth over prior 12Gb/s expanders without compromising energy efficiency or package size.

In addition to core functionalities spanning system initialization, LED management, enclosure management, and topology management operations such as discovery and zoning, the SAS4xNN series offers advanced capabilities that address drive spin-up efficiencies, power consumption, out-of-band management, and backplane complexities such as:

- SAS PHY Power Conditions
- Partial and Slumber Power Management
- Universal Bay Management (SFF-TA-1005)

Building upon Broadcom's industry-leading bandwidth aggregation technology, the SAS4xNN series further improves upon prior-generation capabilities when connected to slower SAS and SATA end-devices in the storage system topology. The SAS4xNN bandwidth aggregation solution, called DataBolt2 Bandwidth Optimizer, enables bi-directional data transfers through the topology at the SAS-4 data rate even when connected to devices operating at 6Gb/s or 12Gb/s and employs a new design to further lower latency, increase performance, and improve interoperability in mixed-controller topologies.



### Applications

- SAS/SATA drive enclosures
- External RAID subsystems
- JBOD architectures
- Server backplanes
- Add-in expander boards

### Key Features

- High-density storage enclosures
- 24-, 32-, 40-, 48-port SAS/SATA expanders:
  - Support of SSP initiator and target, SMP initiator and target, and STP initiator and SATA protocols
- 24G SAS interface:
  - 6G, 12G, 24G SAS, and 6Gb/s SATA devices and data transfer rates
  - Spread Spectrum Clocking
  - Initiator and target connect from any PHY
  - Narrow and wide port configuration support

## Key Features (cont.)

- Integrated enclosure processor:
  - ARM Cortex-R4
- DataBolt2 Bandwidth Optimizer (up to 40 ports)
- PHY and T-10 zoning - 255 zones
- Any-to-any port mirroring
- Enhanced, multi-purpose GPIO architecture:
  - Up to 36 GPIO or LED Pins – configurable for link status, drive activity, and fault LED outputs
  - Up to 4 SGPIO, SFF-8485-compliant ports
- Parallel external memory and SPI interface support
- Communication Interfaces:
  - Up to eight I<sup>2</sup>C interfaces for enclosure management services or debug
  - Up to two firmware-controlled UART interfaces for debug CLI or out-of-band communications
  - One dedicated hardware-controlled Serial Debug Port for memory, register access, and expander recovery
- JTAG support
- Hardware Secure Boot
- FPB42NGS, 27 mm x 27 mm

## Highlights

Implementation of SAS-4 technology in the SAS4xNN series expanders addresses the performance demands of next generation PCIe 4.0 and SAS-4 systems by maximizing the available throughput to the host.

SAS-4 doubles the effective bandwidth of the link through the 128b/130b data encoding scheme and utilizes the Forward Error Correction protocol to increase data integrity at the SAS-4 rate of operation.

Broadcom's utilization of the Close Primitive Parameter, introduced in the SPL-4 specification, enhances the consistency of system performance in cascaded topologies by extending arbitration fairness priority to adjacent expanders in the topology.

The support of Power Control Primitives in Broadcom expanders further benefits storage system scaling by providing more deterministic spin-up of drives to enhance the overall operation of SAS JBODs, while Broadcom's industry-hardened SAS architecture ensures robust connectivity and superior system manageability.

Unique to the SAS4xNN generation of expanders are security features that authenticate the expander firmware before the candidate firmware is allowed to execute. The implementation, referred to as Hardware Secure Boot, relies on Secure Hashing Algorithm (SHA) and public/private key encryption (RSA - Rivest, Shamir, Adleman) to maintain the designated root-of-trust throughout the life of the product.

### 36-Drive RAID/JBOD

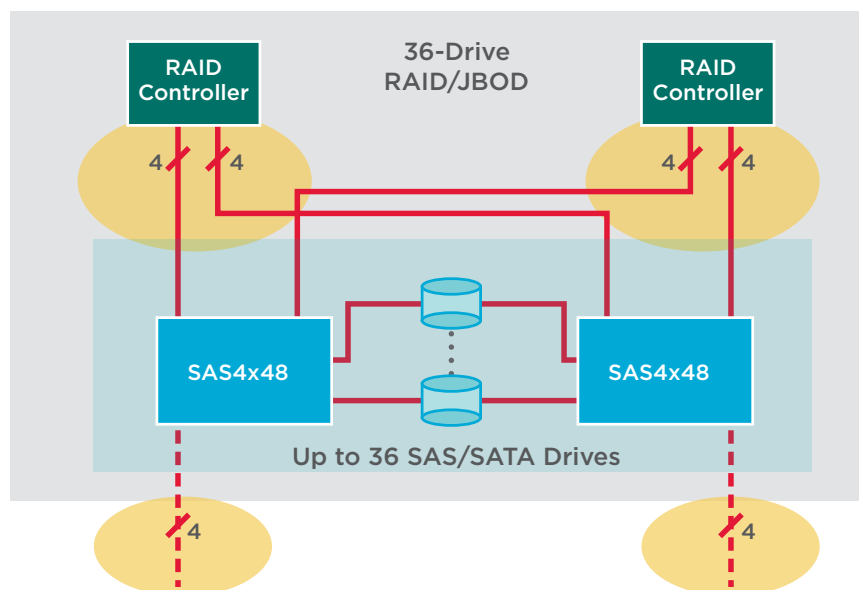

### Enclosure Functions

- LED Control
- Temp Monitoring
- Drive/Array Control
- Fan Control/Monitor
- Power Supply Control/Monitor
- Alarms/Notifications

## Software Development Kit

The Broadcom SAS-4 Software Development Kit (SDK) is a comprehensive, feature-rich tool designed to efficiently accommodate OEM-specific firmware implementations, or to be used as provided. The kit builds upon a solid foundation established over generations of industry-wide testing and real world usage. The SDK consists of a set of object and source code files, build scripts and configuration data. APIs are provided to program the expander, as well as to customize various elements including firmware startup, command line interface (CLI), and SCSI Enclosure services (SES). The modular architectural framework of the SDK accommodates the integration of new features and functions while minimizing changes to pre-existing code, thereby ensuring the portability of customized firmware across multiple generations of Broadcom expanders.

SAS4x48, SAS4x40, SAS4x32, SAS4x24 Expander Technical Specifications	
Feature	Description
SEP	Arm Cortex R4 600 MHz
Internal Memory	4 MB SRAM
SAS Ports	24, 32, 40, 48
Data Transfer Rates	6G, 12G, 24G SAS, and 6Gb/s SATA
DataBolt2 Bandwidth Optimizer	Up to 40 ports (Avago IP)
SSC (Spread Spectrum Clocking)	Yes
Port Mirroring	Yes (Avago IP)
Direct & Subtracting Routing Methods	Yes
Route Table Entries	2048
PHY-based Zoning, T-10 Zoning	Yes
T-10 Optical Support	Yes
A/D Converter	4 (12-bit analog inputs)
Pulse Width Modulator	2
Ethernet Interface	10/100/1000
External Memory Interfaces	8/16-bit parallel NOR Flash with five chip selects SRAM, NV SRAM Serial SPI with up to five chip selects
Security Features	TRNG/Hash and HMAC Generator/Secret Root Key/Hardware Secure Boot
I <sup>2</sup> C Interfaces (max)	8, SMB compliant
SGPIO Interface (max)	4, SFF-8485
UART Interface (max)	2, 16550 compatible
LED (max)	36
GPIO (max)	36
Package	FPB4NGS (27 mm x 27 mm)

Ordering Information	
Description	Part Number
SAS4x48	SX06-0B00-02
SAS4x40	SX07-0B00-02
SAS4x32	SX08-0B00-02
SAS4x24	SX09-0B00-02