

DESCRIPTION

The EV3214DQ-00A is an evaluation board for the MP3214, a low noise, high current LED driver intended for camera phone application. It can drive LEDs at up to 500mA with an input supply of 2.7 to 5.5 volts.

The high efficiency and low external parts count (two small bypass caps, two small charge pump caps and one programming resistor) make the MP3214 ideally suited for portable applications where small size and high efficiency are critical.

The MP3214 employs an efficient inductor less charge pump with 1x, 1.5x and 2x automatic mode control to achieve high efficiency power conversions.

ELECTRICAL SPECIFICATIONS

Parameter	Symbol	Value	Units
Input Voltage	V _{BATT}	2.7-5.5	V
LED of flash Current	IF LASH	200	mA

FEATURES

- High efficiency.
- Up to 500mA output current.
- Wide supply range of 2.7V to 5.5V.
- Adjustable output LED current.
- PWM brightness control.
- Open /Short LED protection.
- Thermal shut down protection.
- Under-Voltage protection.
- Available in a 3mm × 3mm 16pins QFN package.

APPLICATIONS

- LED backlight
- LED flash
- LED torch/Flashlight
- Cell phone, Cameras PDA and Handheld equipment

"MPS" and "The Future of Analog IC Technology" are Registered Trademarks of Monolithic Power Systems, Inc.

EV3214DQ-00A EVALUATION BOARD

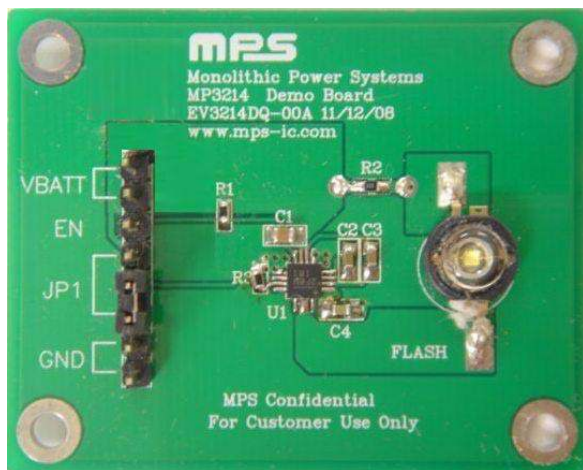

(L x W x H) 2.2" x 1.6" x 0.4"
(6.1cm x 5.1cm x 1.4cm)

Board Number	MPS IC Number
EV3214DQ-00A	MP3214DQ

Efficiency VS. Battery Voltage

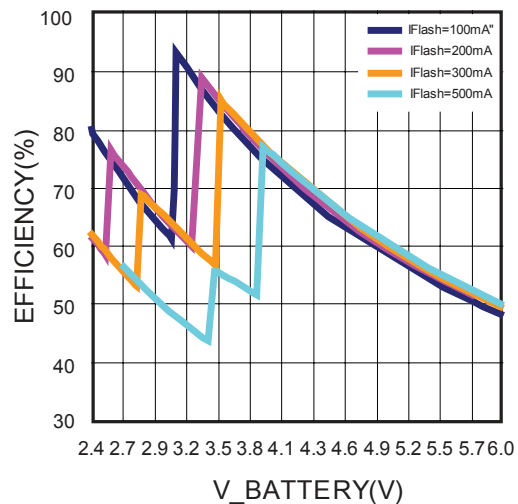

EVALUATION BOARD SCHEMATIC

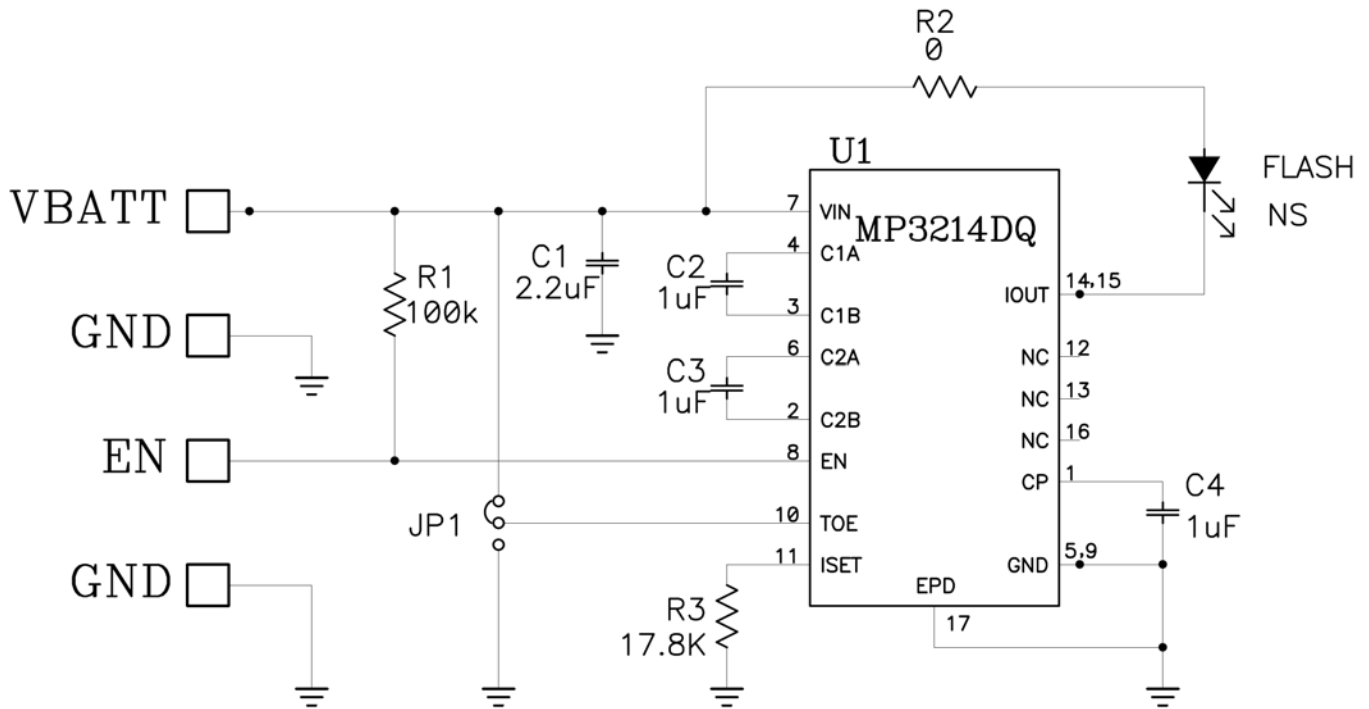

EV3214DQ-00A BILL OF MATERIALS

Qty	Reference	Value	Description	Package	Manufacturer	Manufacturer P/N
1	C1	2.2uF	6.3V X5R Ceramic Cap.	SMR0603	muRata	GRM188R70J225K
3	C2,C3,C4	1uF	6.3V X5R Ceramic Cap.	SMR0603	muRata	GRM188R70J105K
1	Flash	NS	500mA flash LED	SMD	LUMILEDS	LXHL-BW02
1	R1	100KΩ	Film Res., 5%	0603	Yageo	RC0603JR-07100KL
1	R2	0Ω	Film Res., 5%	0603	Yageo	9C06031A0R00JL
1	R3	17.8K	Film Res, 1%	0603	Yageo	9C06031A1782FKHFT
1	JP1	Jumper	3 PIN 2.54 mm	0.1"	Sullins	STC03SYAN
1	U1		White LED Driver	QFN16 3X3	MPS	MP3214DQ

PRINTED CIRCUIT BOARD LAYOUT

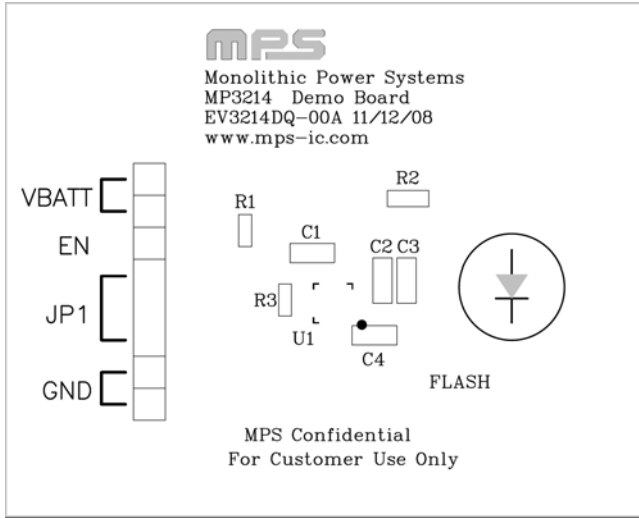

Figure 1—Top Silk Layer

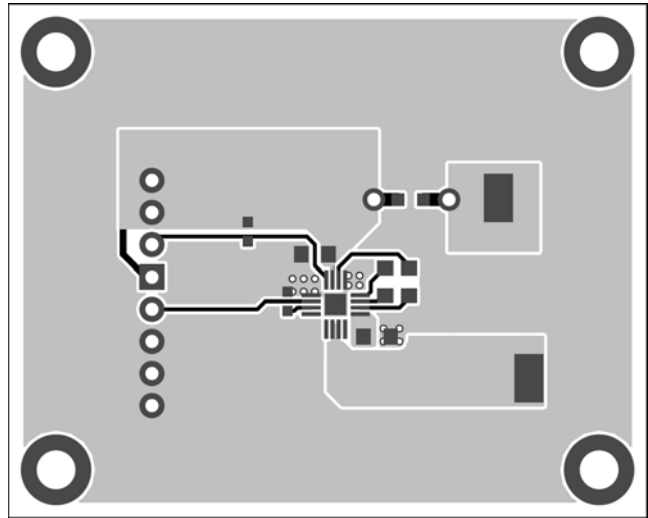

Figure 2—Top Layer

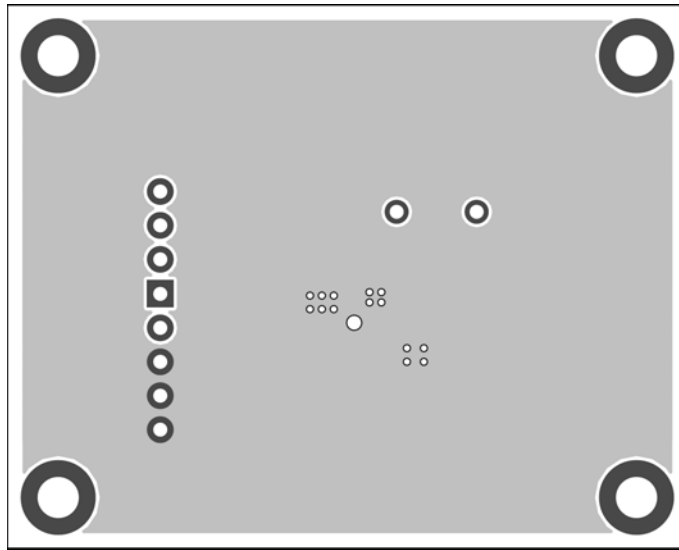

Figure 3—Bottom Layer

QUICK START GUIDE

1. Solder Flash LED to the board if it is not populated.
2. Preset the power supply output to between 2.7V and 5.5 V, Then turn off the power supply.
3. Connect the positive terminal of the power supply to the VBATT pin.
4. Connect the negative terminal of the power supply to the GND pin.
5. Set the JP1 connection. Such that the TOE pin is connected to VBATT.
6. Turn on the power supply. The board will automatically start up.
7. Set the Flash LED current. The IFLASH is set by the resistor R3 and follows equation:

$$IFLASH = \frac{3570}{R3}$$

or for a desired IFLASH, R3 is calculated by:

$$R3 = \frac{3570}{IFLASH}$$

R3	IFLASH
35700Ω	100mA
17850Ω	200mA
11900Ω	300mA
8925Ω	400mA
7140Ω	500mA

8. A low frequency PWM signal apply to the EN pin (50HZ to 2KHz) can be used to change the LED brightness. For example, if a 20% duty cycle PWM signal is applied to the EN pin, the average IFLASH is 20% the full current.

NOTICE: The information in this document is subject to change without notice. Users should warrant and guarantee that third party Intellectual Property rights are not infringed upon when integrating MPS products into any application. MPS will not assume any legal responsibility for any said applications.