

RECOMMENDED PANEL CUT-OUT FOR  $\frac{.089}{.035}$ / $\frac{3.20}{1.26}$  THICK PANEL  
TOLERANCE  $\pm 0.10$ /.004  
SHOWN FROM MATING SIDE

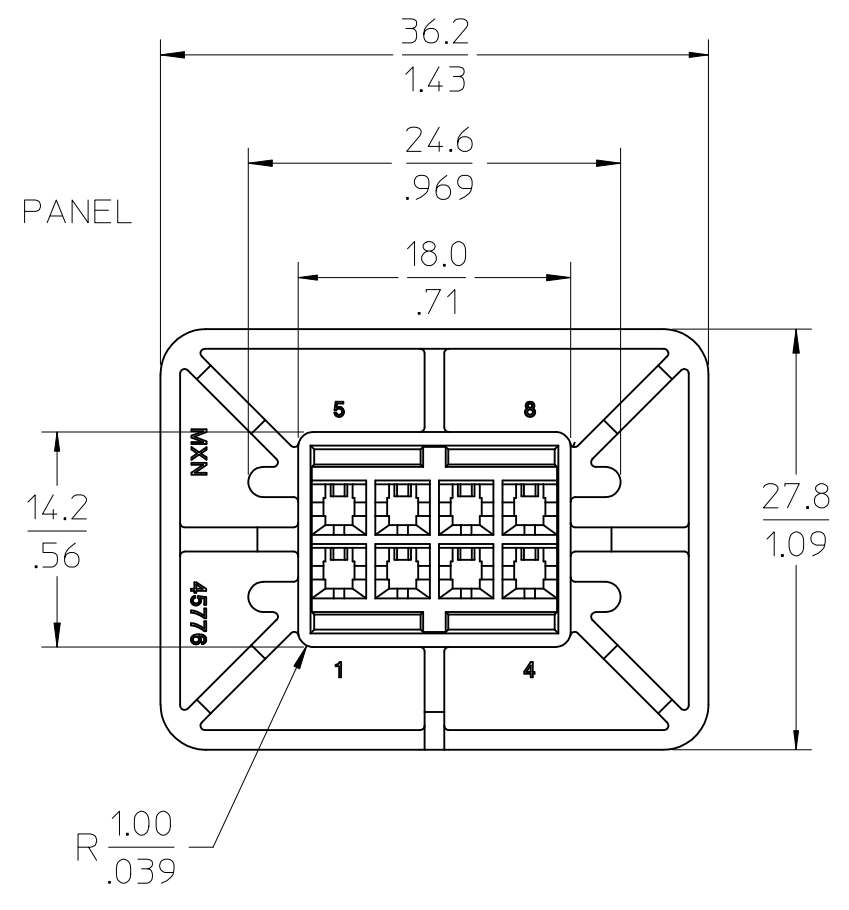
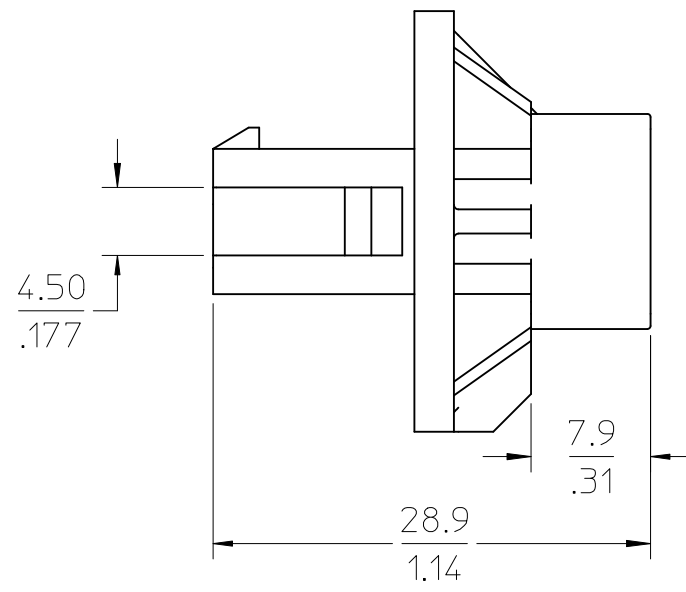

- NOTES:
1. MATERIAL: NYLON(PA6), UL94V-2, COLOR: NATURAL, IEC 60335-1 4th EDITION GLOW WIRE CAPABLE
  2. FINISH: N/A
  3. PRODUCT SPECIFICATION: TBD
  4. PACKAGING: BULK PACKAGED PER PK-45776-001
  5. THIS PART IS DESIGNED TO USE MINI-FIT MALE CRIMP TERMINALS #5558.
  6. THIS PART MATES WITH RECEPTACLE #5557.
  7. WIRES TO BE DRESSED IN SUCH A MANNER TO ALLOW TERMINALS TO FLOAT FREELY IN THE POCKET.
  8. CONNECTORS ARE NOT TO BE MATED OR UNMATED WHILE CIRCUITS ARE LIVE.
  9. PART CONFORMS TO CLASS "B" REQUIREMENTS OF COSMETIC SPECIFICATION PS-45499-002.

ADD RADIUSES EC NO: UCP2010-2103 DRWN: J JAGUILAR 2010/05/24 CHKD: JBELL 2010/05/24 APPR: FSMITH 2010/09/08	QUALITY SYMBOLS ▽=0 ▽=0	GENERAL TOLERANCES (UNLESS SPECIFIED)		DIMENSION STYLE MM/IN		SCALE 2:1	DESIGN UNITS METRIC	THIRD ANGLE PROJECTION		
			mm	INCH	DRAWN BY TRBENES	DATE 2009/03/19	TITLE 8 CIRCUIT FOAM-IN-PLACE MINI FIT PLUG HOUSING			
		4 PLACES	± ---	± ---	CHECKED BY JBELL	DATE 2009/03/19				
		3 PLACES	± ---	± .010	APPROVED BY FSMITH	DATE 2009/03/19				
			ANGULAR ±1/2°		MATERIAL NO. 457761008	DOCUMENT NO. RSD-45776-002	SHEET NO. 1 OF 1			
		DRAFT WHERE APPLICABLE MUST REMAIN WITHIN DIMENSIONS		SIZE B	THIS DRAWING CONTAINS INFORMATION THAT IS PROPRIETARY TO MOLEX INCORPORATED AND SHOULD NOT BE USED WITHOUT WRITTEN PERMISSION					