

mikromedia™

for PIC24EP®

Compact development system rich with on-board peripherals for all-round multimedia development on PIC24EP512GU810 device.



TO OUR VALUED CUSTOMERS

I want to express my thanks to you for being interested in our products and for having confidence in MikroElektronika.

The primary aim of our company is to design and produce high quality electronic products and to constantly improve the performance thereof in order to better suit your needs.

A white, stylized handwritten signature on a dark blue background. The signature is fluid and cursive, starting with a large 'N' and ending with a long horizontal stroke.

Nebojsa Matic
General Manager

Table of Contents

Introduction to mikromedia for PIC24EP®	4	Programming with mikroProg™ programmer	16
Package contains	5	mikroProg Suite™ for PIC® software	17
Key features	6	Programming with ICD2® or ICD3® programmer	18
System specifications	7	4. Reset button	20
1. Power supply	8	5. Crystal oscillator	22
USB power supply	8	6. microSD card slot	24
Battery power supply	8	7. Touch screen	26
2. PIC24EP512GU810 microcontroller	10	8. Audio module	28
Key microcontroller features	10	9. USB connection	30
3. Programming the microcontroller	11	10. Accelerometer	32
Programming with mikroBootloader	12	11. Flash memory	34
step 1 - Connecting mikromedia	12	12. Pads	36
step 2 - Browsing for .HEX file	13	13. Pinout	37
step 3 - Selecting .HEX file	13	14. Dimensions	38
step 4 - Uploading .HEX file	14	15. mikromedia accessories	39
step 5 - Finish upload	15	What's next?	40

Introduction to mikromedia for PIC24EP[®]

The **mikromedia for PIC24EP[®]** is a compact development system with lots of on-board peripherals which allow development of devices with multimedia contents. The central part of the system is a 16-bit **PIC24EP512GU810** microcontroller. The mikromedia for PIC24EP[®] features integrated modules such as stereo MP3 codec, **TFT 320x240 touch screen** display, accelerometer, USB connector, audio connector, MMC/SD card slot, 8 Mbit flash memory, 2x26 connection pads and other. It comes pre-programmed with USB HID bootloader, but can also be programmed with external programmers, such as mikroProg[™] or ICD2/3. Mikromedia is compact and slim, and perfectly fits in the palm of the hand, which makes it a convenient platform for mobile devices.



Package contains



- 01 Damage resistant protective box



- 02 mikromedia for PIC24EP[®] development system

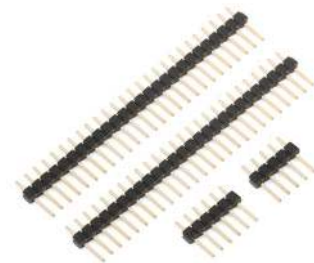

- 03 Two 1x26 male headers, one 1x6 and one 1x5 header



- 04 user's guide



- 05 schematic and pinout



- 06 USB cable

Key features

- 01 RESET button
- 02 Connection pads
- 03 TFT 320x240 display
- 04 USB MINI-B connector
- 05 CHARGE indication LED
- 06 LI-Polymer battery connector
- 07 3.5mm headphone connector
- 08 Power supply regulator
- 09 Serial flash memory
- 10 VS1053 stereo mp3 coder/decoder
- 11 PIC24EP512GU810 microcontroller
- 12 Accelerometer
- 13 Crystal oscillator
- 14 Power indication LED
- 15 microSD card slot
- 16 ICD2/3 connector
- 17 mikroProg connector

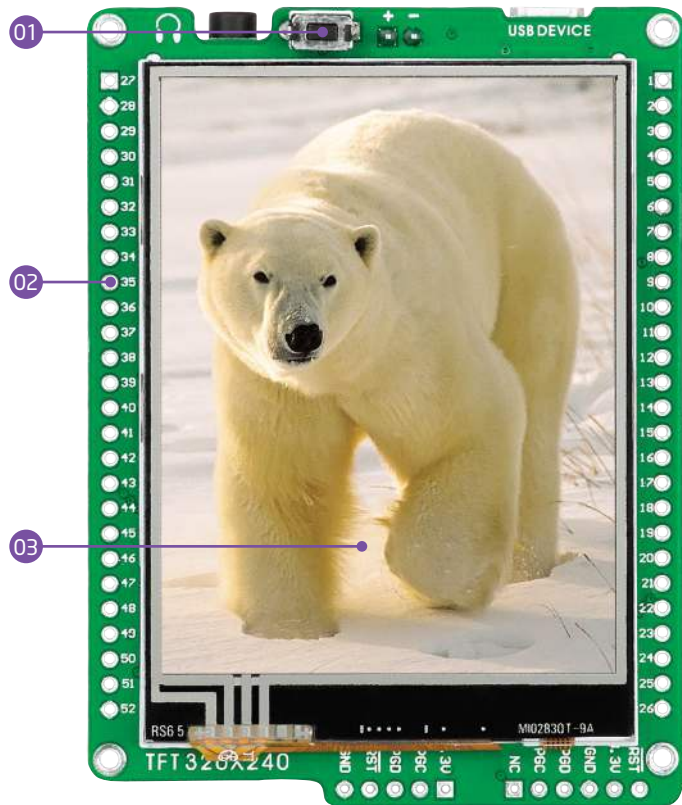

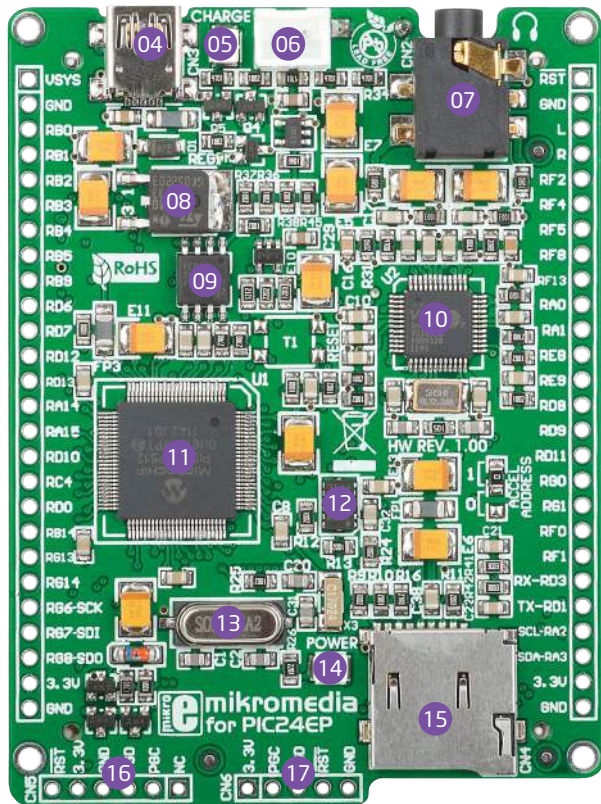

System specifications



power supply

Via USB cable (5V DC)



power consumption

73 mA with erased MCU (when on-board modules are inactive)



board dimensions

81.2 x 60.5 mm (3.19 x 2.38 inch)



weight

~50g (0.11lbs)



class B product

Product complies with the Class B limit of EN 55022 and can be used in the domestic, residential, commercial and industrial environments.



CAUTION: Electrostatic Sensitive Device

Permanent damage may occur on devices subjected to high energy electrostatic discharges which readily accumulate on the human body or test equipment and can discharge without detection.

1. Power supply



Figure 1-1:
Connecting USB
power supply

USB power supply

You can apply power supply to the board using the **MINI-B USB** cable provided in the package. On-board voltage regulators provide the appropriate voltage levels to each component on the board. **Power LED (GREEN)** will indicate the presence of power supply.

Battery power supply

You can also power the board using a **Li-Polymer** battery, via on-board battery connector. On-board battery charger circuit **MCP73832** enables you to charge the battery over a USB connection. **LED diode (RED)** will indicate when the battery is charging. Charging current is $\sim 250\text{mA}$ and charging voltage is 4.2V DC .

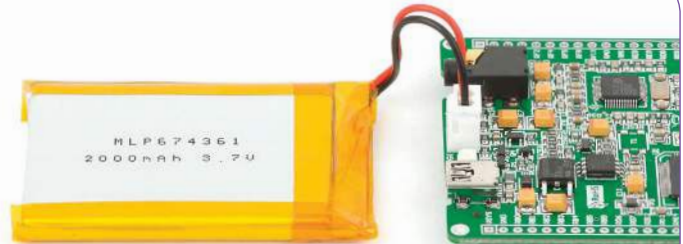

Figure 1-2: Connecting a Li-Polymer battery

2. PIC24EP512GU810 microcontroller

The **mikromedia for PIC24EP®** development system comes with the **PIC24EP512GU810** microcontroller. This high-performance 16-bit microcontroller with its integrated modules and in combination with other on-board modules is ideal for multimedia applications.

Key microcontroller features

- Up to **70 MIPS** Operation;
- 16-bit architecture;
- 512KB of program memory, 24KB of auxiliary flash;
- 53.248 Bytes of RAM;
- 83 I/O pins;
- Internal Oscillator 7.37 MHz, 32kHz; RTCC;
- nanoWatt features: Fast Wake/Fast Control;
- 4-UART, 4-SPI, 2-I2C, 2-CAN, USB 2.0 OTG;
- DAC, ADC, etc.

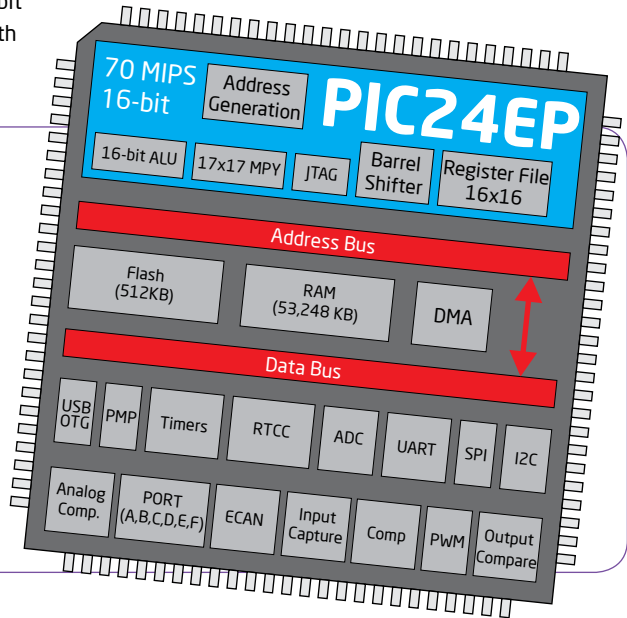

3. Programming the microcontroller

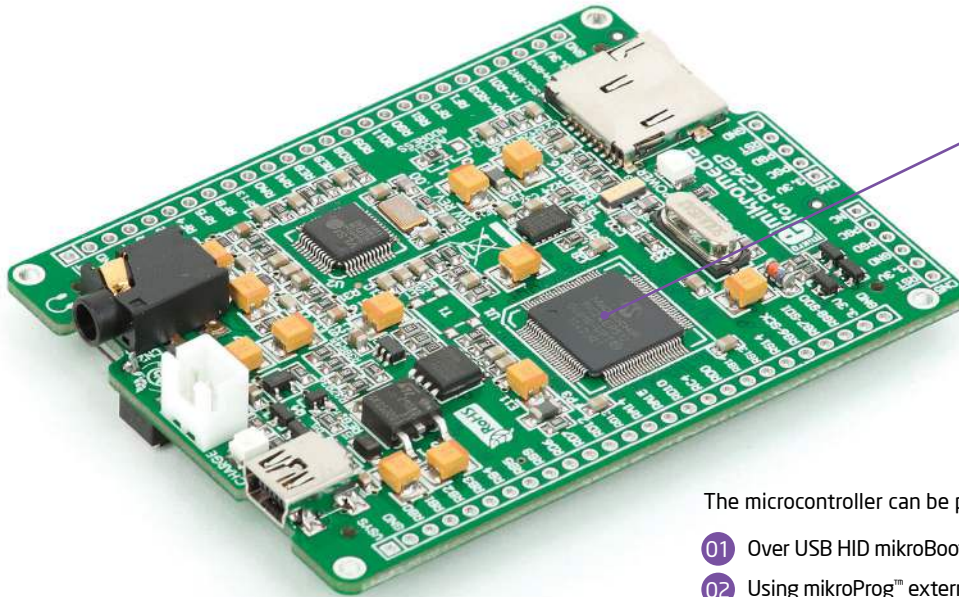

Figure 3-1:
PIC24EP512GU810
microcontroller

The microcontroller can be programmed in three ways:

- 01 Over USB HID mikroBootloader
- 02 Using mikroProg™ external programmer
- 03 Using ICD2/3 external programmer

Programming with mikroBootloader

You can program the microcontroller with the bootloader which is preprogrammed into the device by default. To transfer .hex file from a PC to the MCU you need bootloader software (**mikroBootloader USB HID**) which can be downloaded from:



http://www.mikroe.com/downloads/get/1858/mikrobootloader_pic24ep_usbhid_v210.zip

Upon download, unzip it to desired location and start the mikroBootloader application:

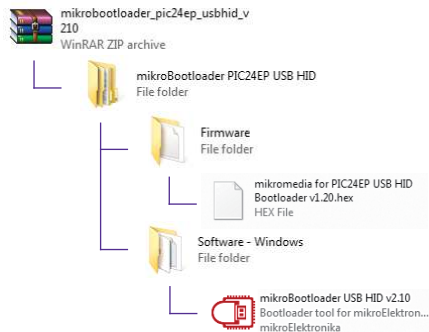

step 1 - Connecting mikromedia



Figure 3-2: USB HID mikroBootloader window

- 01** In order to start, connect the USB cable or (if already connected) press the **Reset** button on your mikromedia board. Click the **Connect** button within 5s to enter the bootloader mode, otherwise the existing microcontroller program will be executed.

step 2 - Browsing for .HEX file



Figure 3-3: Browse for HEX

- 01 Click the **Browse for HEX** button and from a pop-up window (Figure 3.4) choose the .HEX file which will be uploaded to MCU memory.

step 3 - Selecting .HEX file

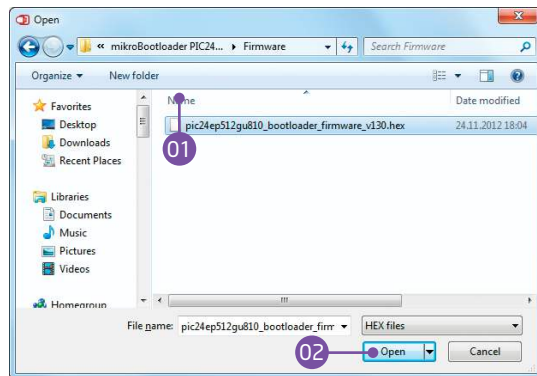

Figure 3-4: Selecting HEX

- 01 Select .HEX file using open dialog window.
- 02 Click **Open**.

step 4 - Uploading .HEX file



Figure 3-5: Begin uploading

01 To start .HEX file boot loading click the **Begin uploading** button.



Figure 3-6: Progress bar

01 .HEX file uploading can be monitored via progress bar.

step 5 - Finish upload



Figure 3-7: Restarting MCU

- 01** Click **OK** after uploading is finished and wait for 5 seconds. Board will automatically reset and your new program will execute.



Figure 3-8: mikroBootloader ready for next job

Programming with mikroProg™ programmer

The microcontroller can be programmed with **mikroProg™ programmer** and **mikroProg Suite™ for PIC®** software. To connect mikroProg™ programmer to the development system use the CN6 connector, **Figure 3-9**.



Figure 3-9:
Connecting mikroProg™ to mikromedia™

mikroProg™ is a fast USB 2.0 programmer with mikroICD™ hardware In-Circuit Debugger. Smart engineering allows mikroProg™ to support PIC10®, PIC12®, PIC16®, PIC18®, dsPIC30/33®, PIC24® and PIC32® devices in a single programmer. It supports over 570 microcontrollers from Microchip®. Outstanding performance, easy operation and elegant design are its key features.

mikroProg suite™ for PIC® software



mikroProg™ programmer requires special programming software called **mikroProg Suite™ for PIC®**. This software is used for programming of ALL Microchip® microcontroller families, including PIC10®, PIC12®, PIC16®, PIC18®, dsPIC30/33®, PIC24® and PIC32®. Software has intuitive interface and SingleClick™ programming technology. Just by downloading the latest version of **mikroProg Suite™** your programmer is ready to program new devices. **mikroProg Suite™** is updated regularly, at least four times a year, so your programmer will be more and more powerful with each new release.

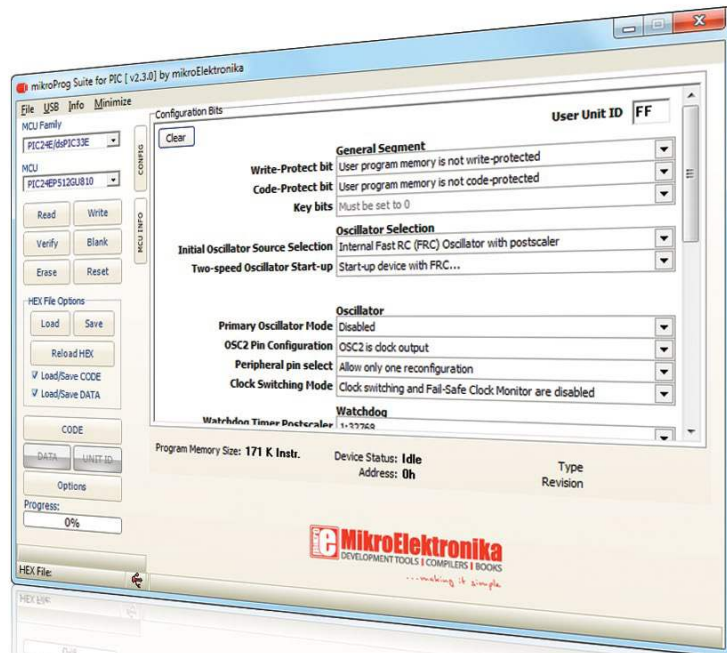

Figure 3-10: Main Window of mikroProg Suite™ for PIC® programming software

Programming with ICD2[®] or ICD3[®] programmer

The microcontroller can also be programmed with **ICD2[®]** or **ICD3[®] programmer**. These programmers connects with mikromedia board via **ICD2 CONNECTOR BOARD**.

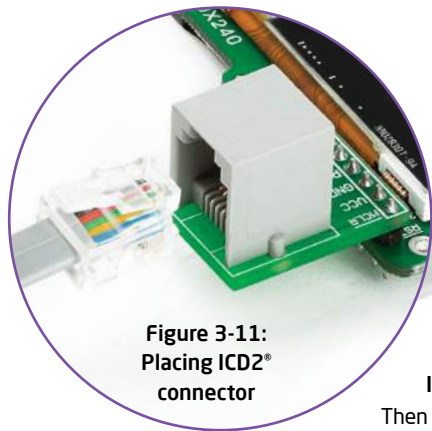

Figure 3-11:
Placing ICD2[®]
connector

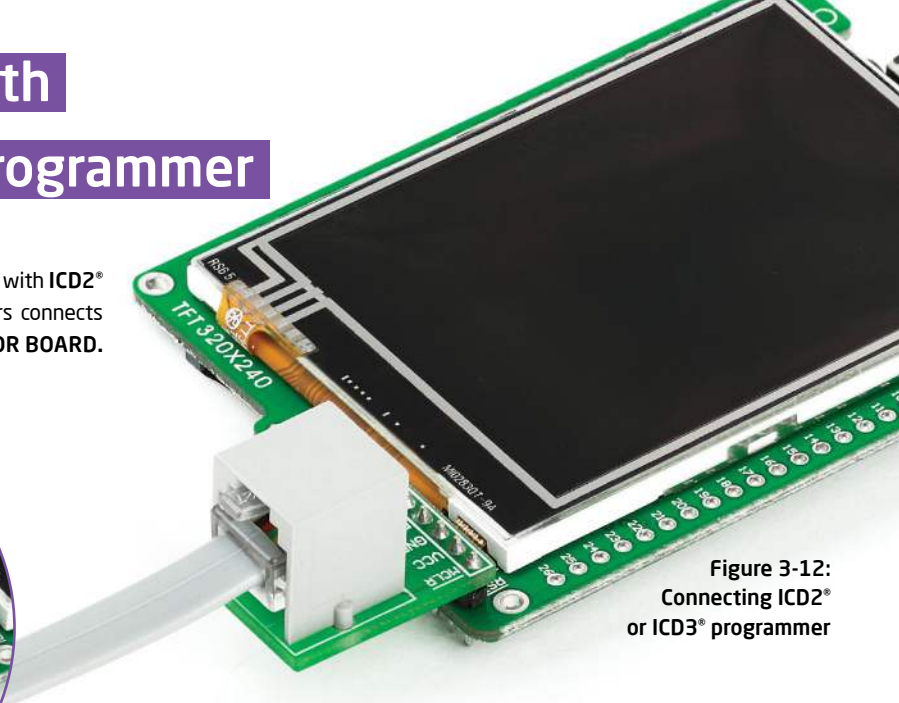

Figure 3-12:
Connecting ICD2[®]
or ICD3[®] programmer

In order to enable the ICD2[®] and ICD3[®] programmers to be connected to the mikromedia board, it is necessary to provide the appropriate connector such as the **ICD2 CONNECTOR BOARD**. This connector should be first soldered on the CN5 connector. Then you should plug the ICD2[®] or ICD3[®] programmer into it, **Figure 3-11**.

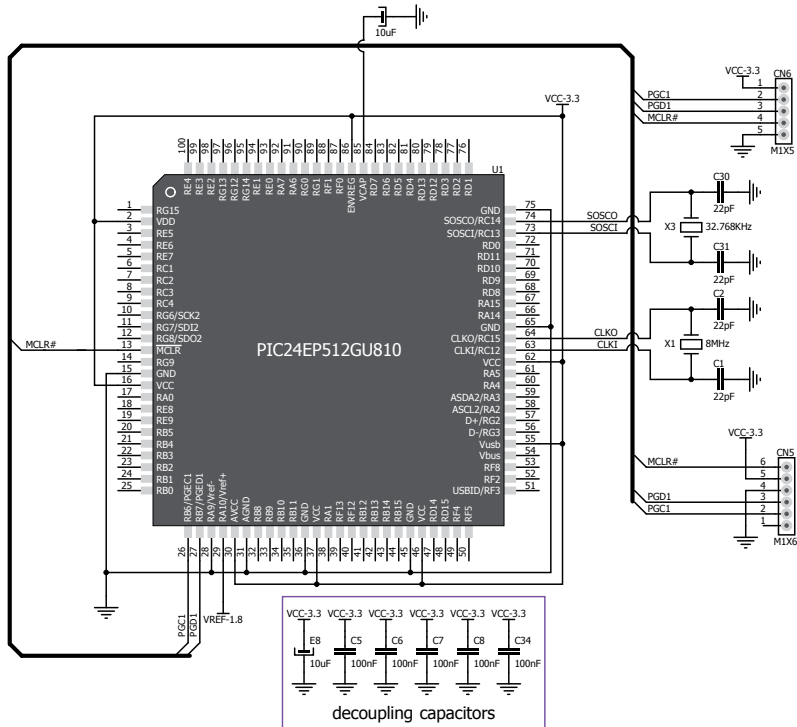
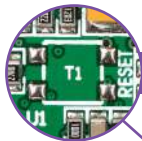

Figure 3-13: mikroProg™ & ICD2 / ICD3 programmer connection schematic

4. Reset button

Board is equipped with reset button, which is located at the top of the front side (**Figure 4-2**). If you want to reset the circuit, press the reset button. It will generate low voltage level on microcontroller reset pin (input). In addition, a reset can be externally provided through **pin 27** on side headers (**Figure 4-3**).



NOTE

*You can also solder additional reset button on the appropriate place at the back side of the board, **Figure 4-1**.*

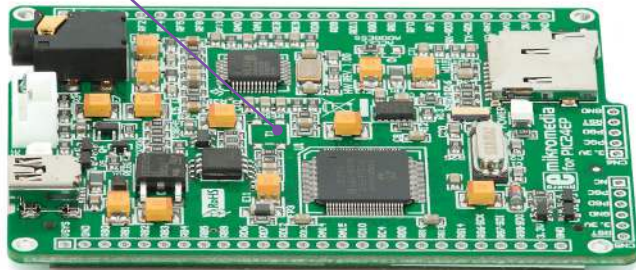

Figure 4-1: Location of additional reset button

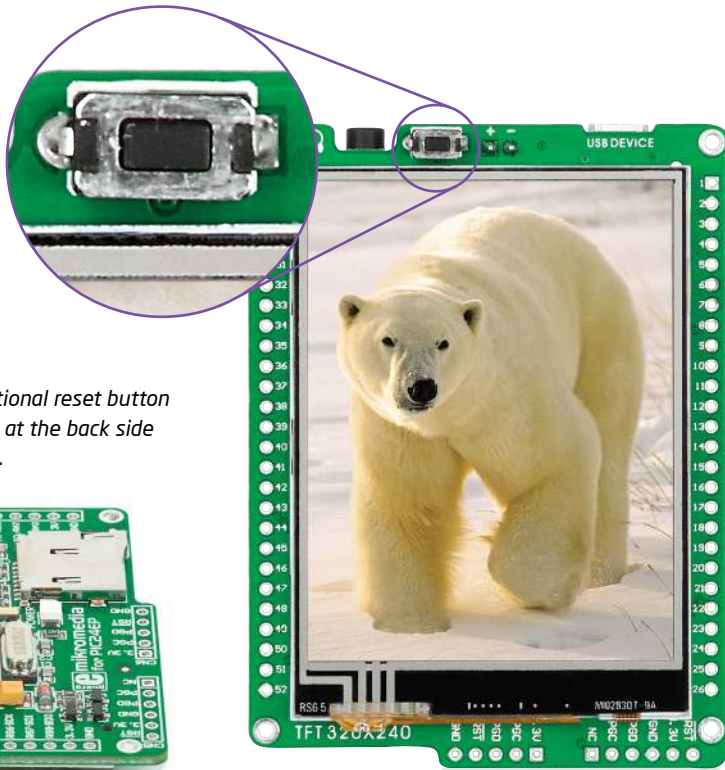

Figure 4-2: Frontal reset button

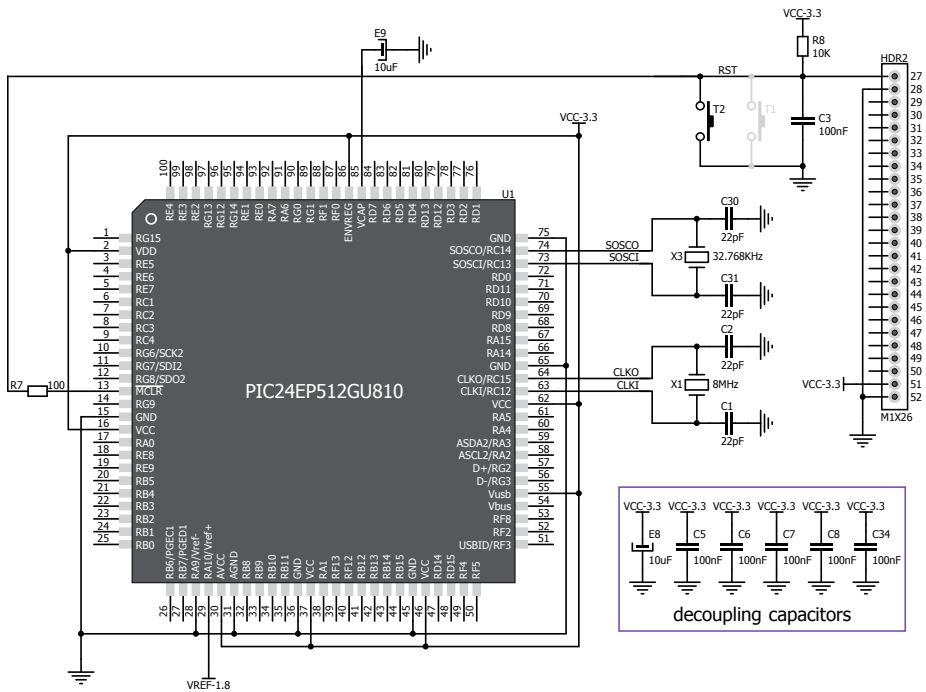
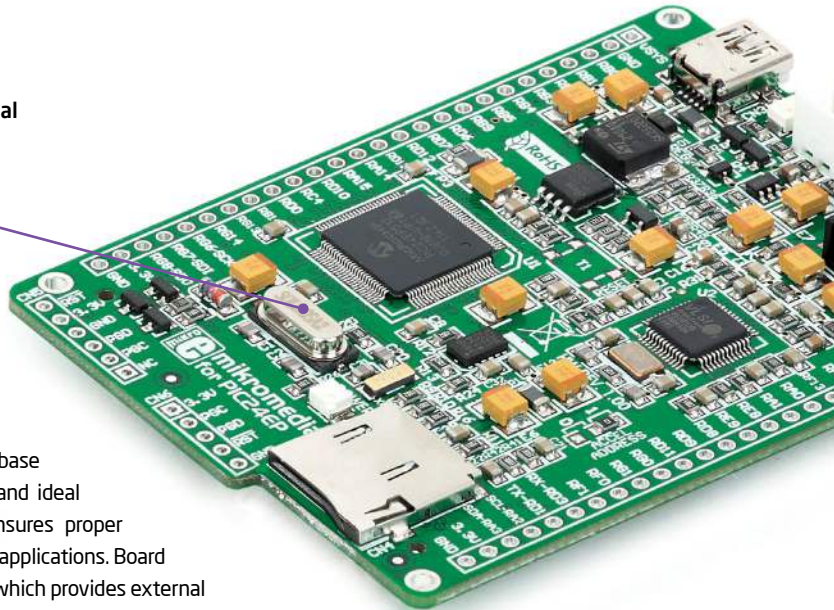

Figure 4-3: Reset circuit schematic

5. Crystal oscillator



Figure 5-1:
External crystal
oscillator (X1)



Board is equipped with **8MHz crystal oscillator (X1)** circuit that provides external clock waveform to the microcontroller CLK0 and CLK1 pins. This base frequency is suitable for further clock multipliers and ideal for generation of necessary USB clock, which ensures proper operation of bootloader and your custom USB-based applications. Board also contains **32.768kHz Crystal oscillator (X3)** which provides external clock for internal **RTCC** module.

NOTE : *The use of crystal in all other schematics is implied even if it is purposely left out, because of the schematics clarity.*

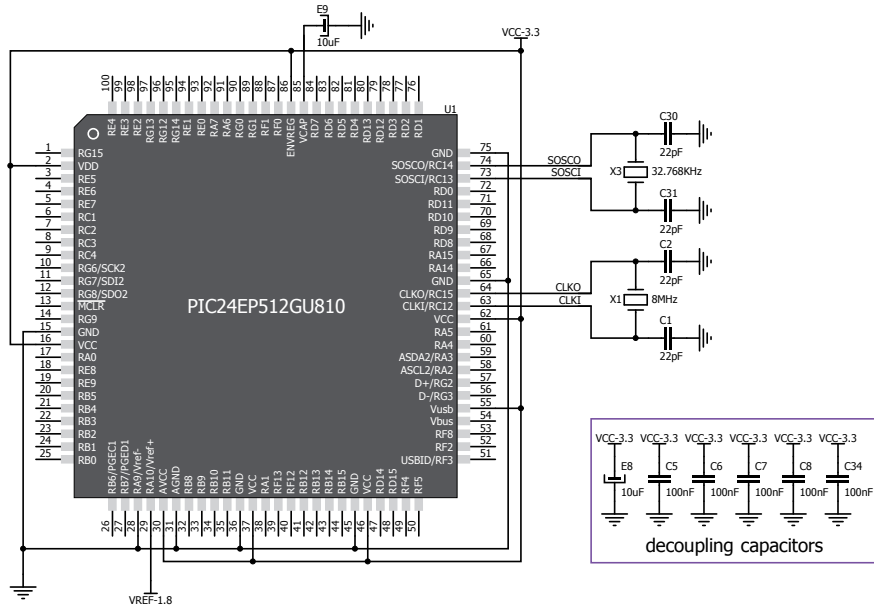

Figure 5-2:Crystal oscillator schematic

6. microSD card slot

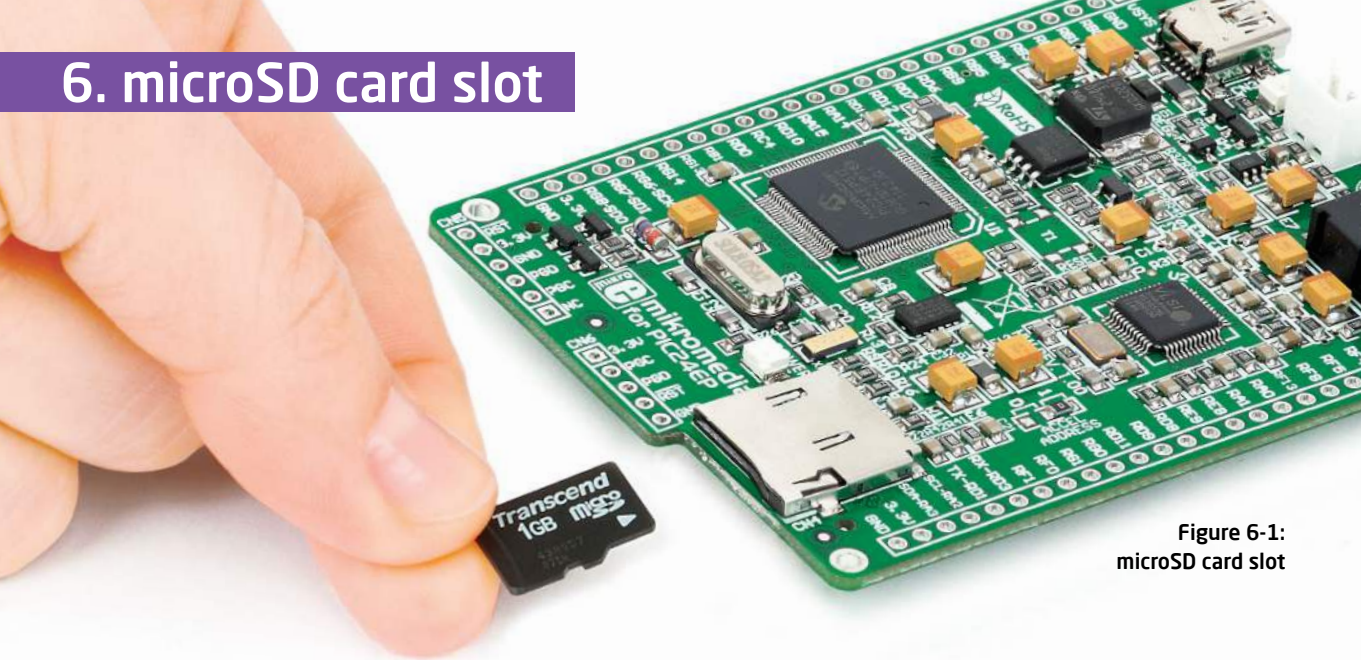

Figure 6-1:
microSD card slot

Board contains **microSD card slot** for using microSD cards in your projects. It enables you to store large amounts of data externally, thus saving microcontroller memory. microSD cards use Serial Peripheral Interface (**SPI**) for communication with the microcontroller.

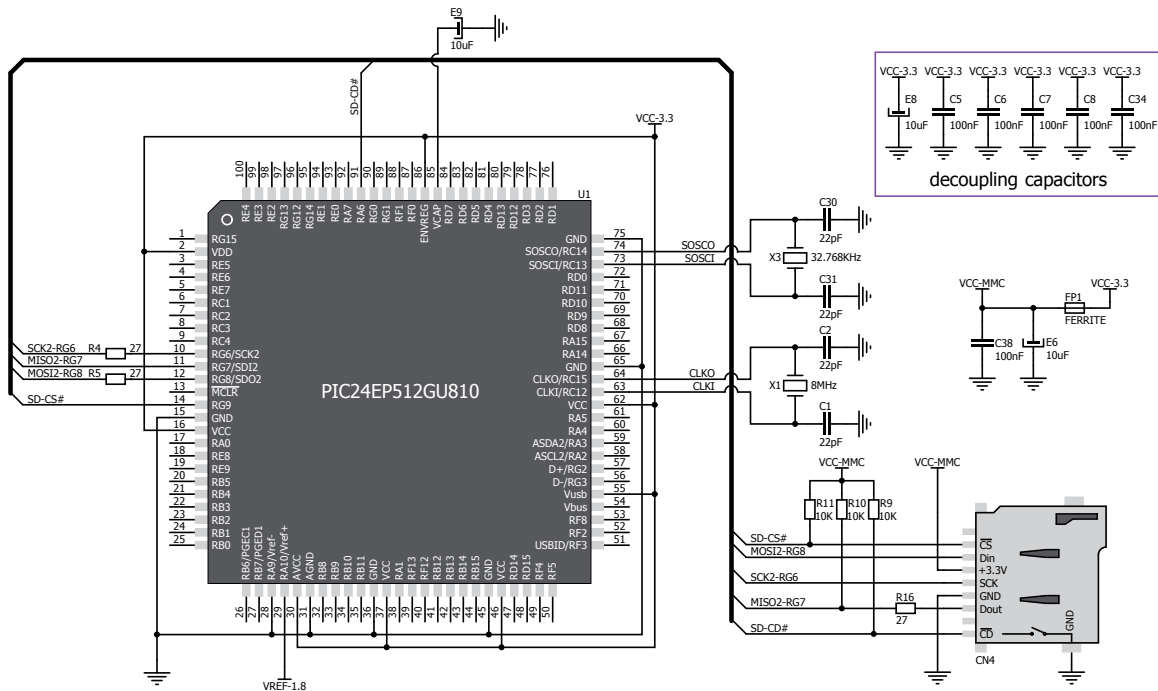
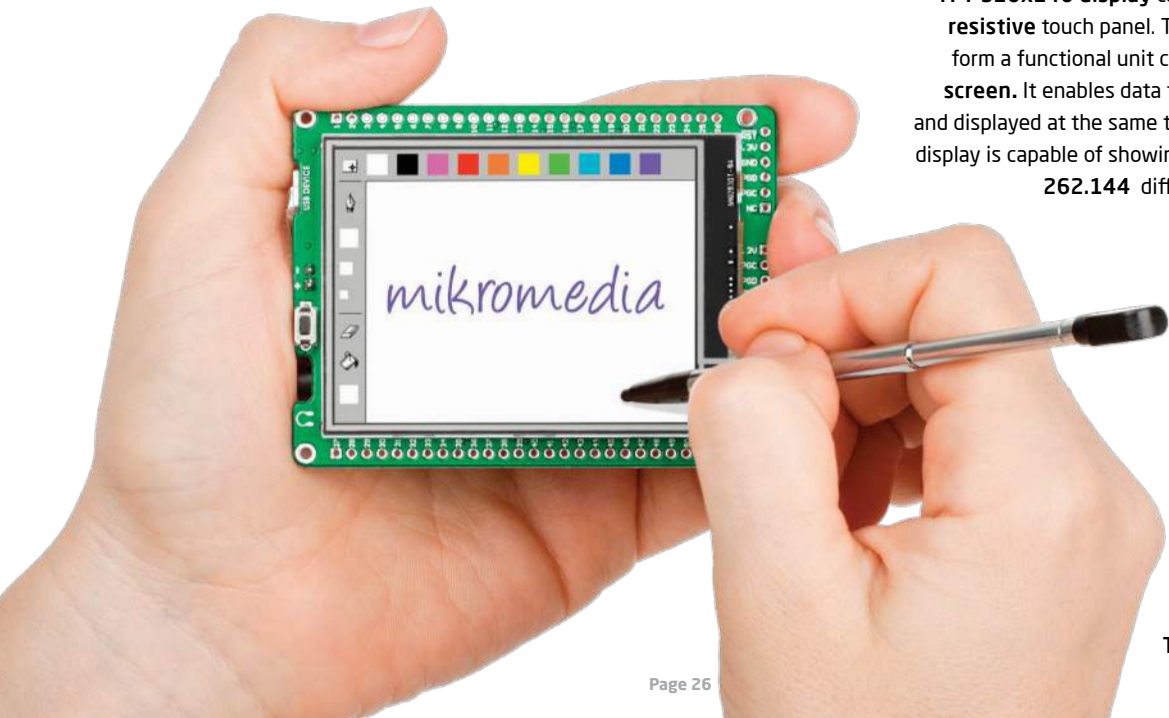

Figure 6-2: microSD Card Slot module connection schematic

7. Touch screen



The development system features a **TFT 320x240 display** covered with a **resistive** touch panel. Together they form a functional unit called a **touch screen**. It enables data to be entered and displayed at the same time. The TFT display is capable of showing graphics in **262.144** different colors.

Figure 7-1:
Touch Screen

8. Audio module



Figure 8-1:
On-board VS1053
MP3 codec

The mikromedia for PIC24EP® features a stereo audio codec **VS1053**. This module enables audio reproduction by using stereo headphones connected to the system via a **3.5mm** connector CN2. All functions of this module are controlled by the microcontroller over Serial Peripheral Interface (**SPI**).

Figure 8-2:
Inserting 3.5mm
headphones jack

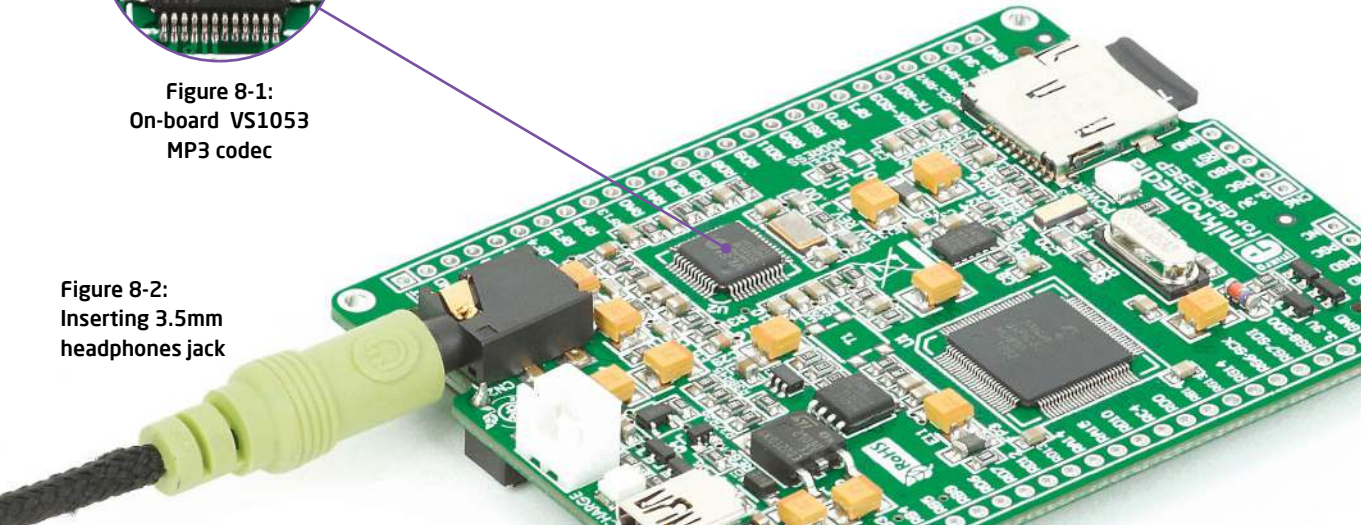

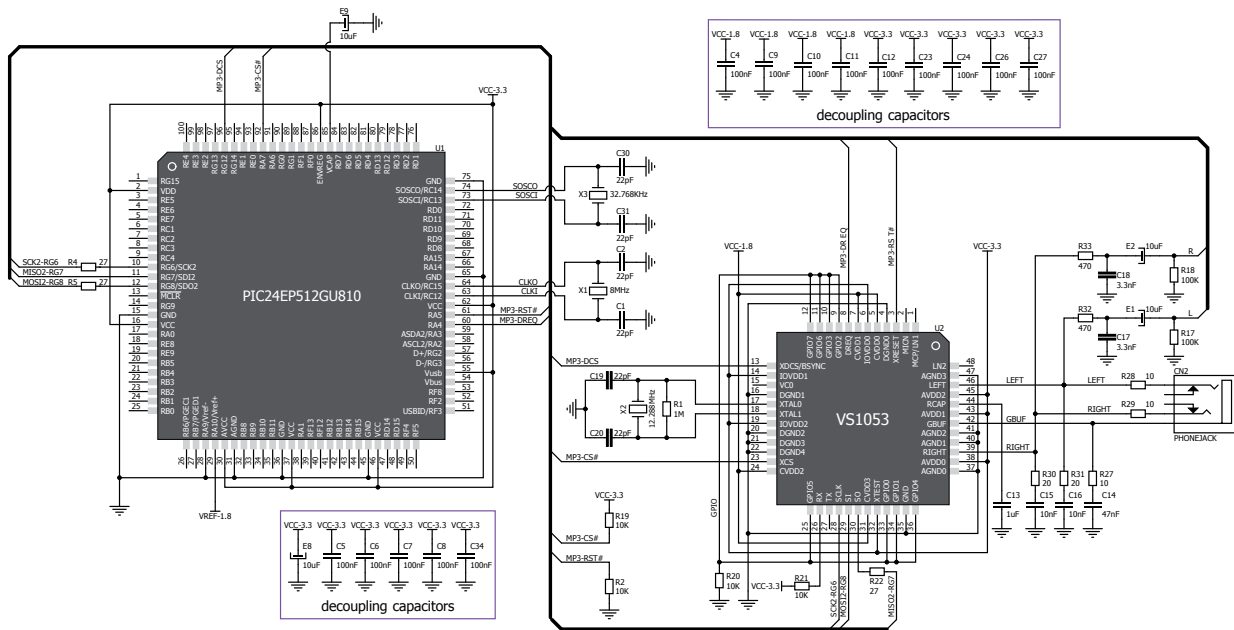

Figure 8-3: Audio module connection schematic

9. USB connection

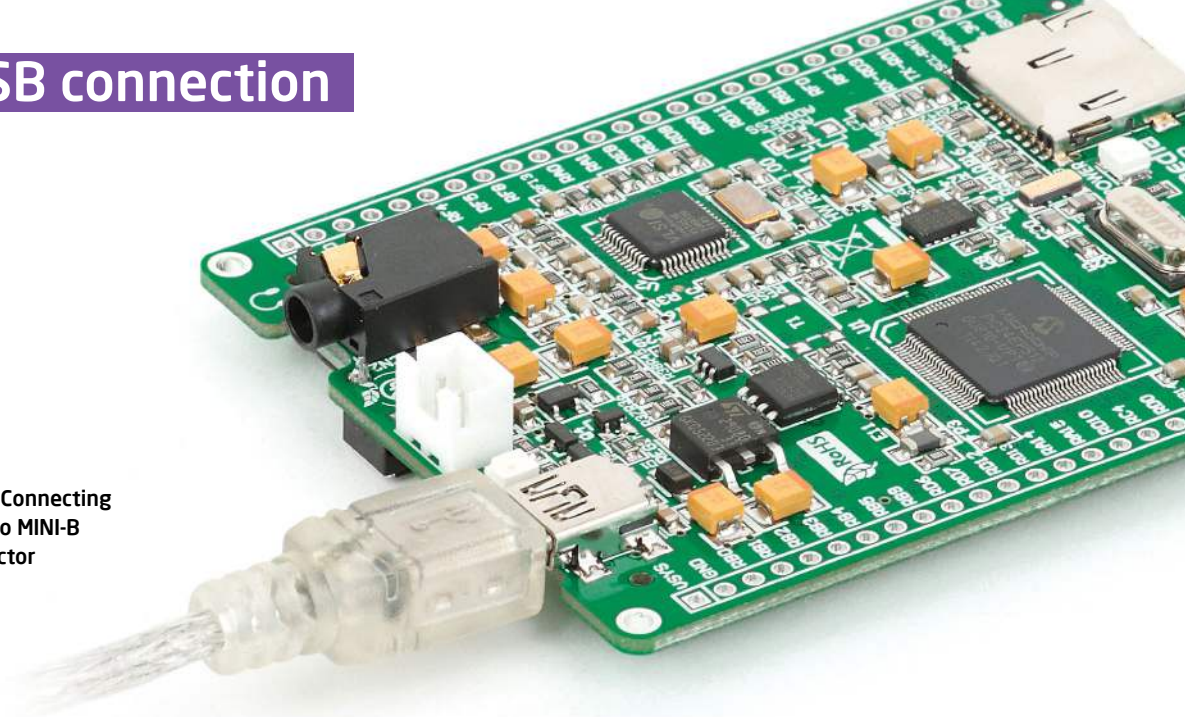

Figure 9-1: Connecting USB cable to MINI-B USB connector

PIC24EP512GU810 microcontroller has an integrated USB module, which enables you to implement USB communication functionality to your mikromedia board. Connection with target USB host is done over MINI-B USB connector which is positioned next to the battery connector.

10. Accelerometer

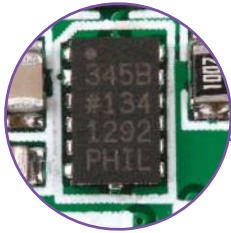
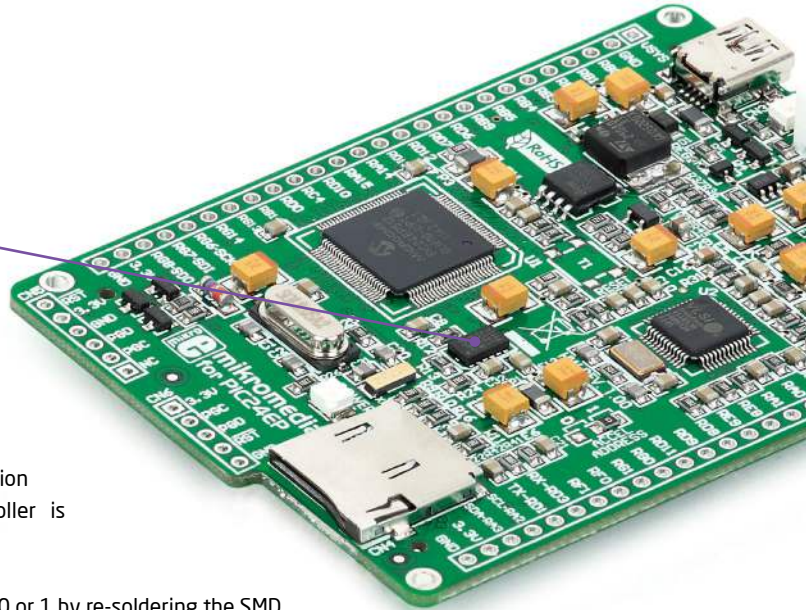

Figure 10-1:
Accelerometer
module



On board **ADXL345** accelerometer is used to measure acceleration in three axis: x, y and z. The accelerometer function is defined by the user in the program loaded into the microcontroller. Communication between the accelerometer and the microcontroller is performed via the **I²C** interface.



You can set the accelerometer address to 0 or 1 by re-soldering the SMD jumper (zero-ohm resistor) to the appropriate position. Jumper is placed in address 1 position by default.

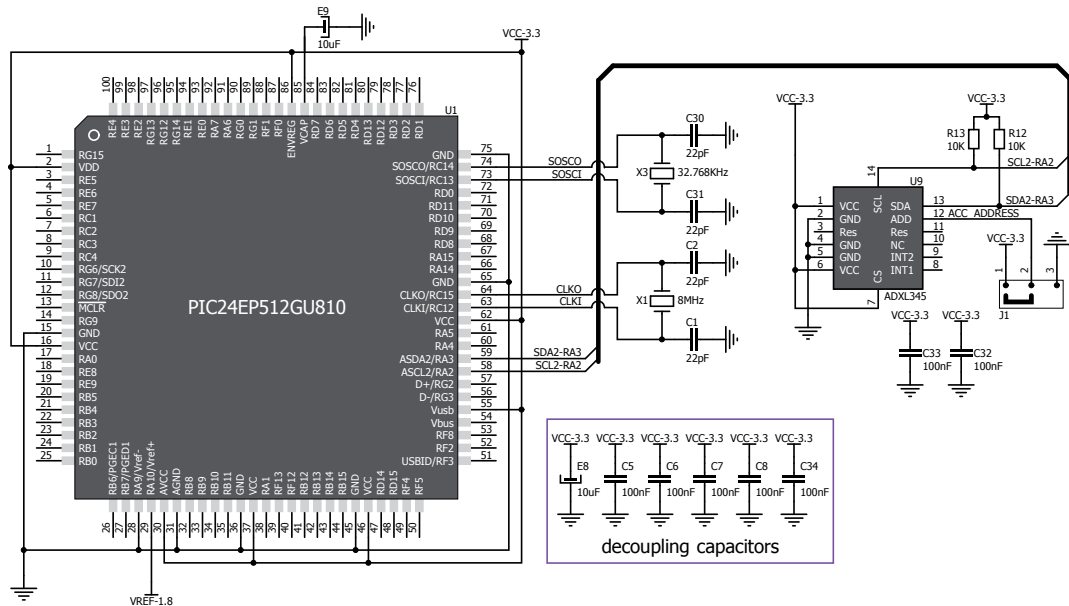
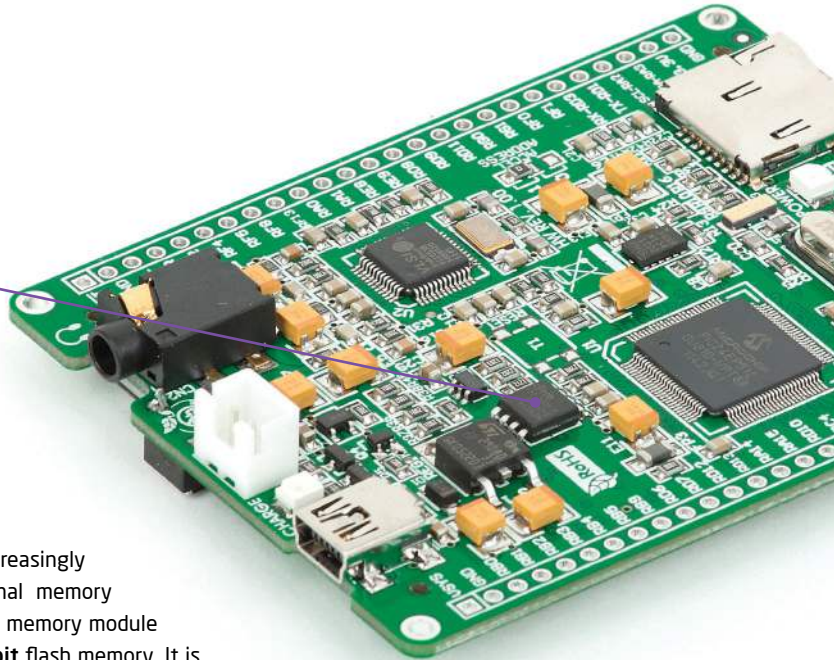

Figure 10-2: Accelerometer connection schematic

11. Flash memory

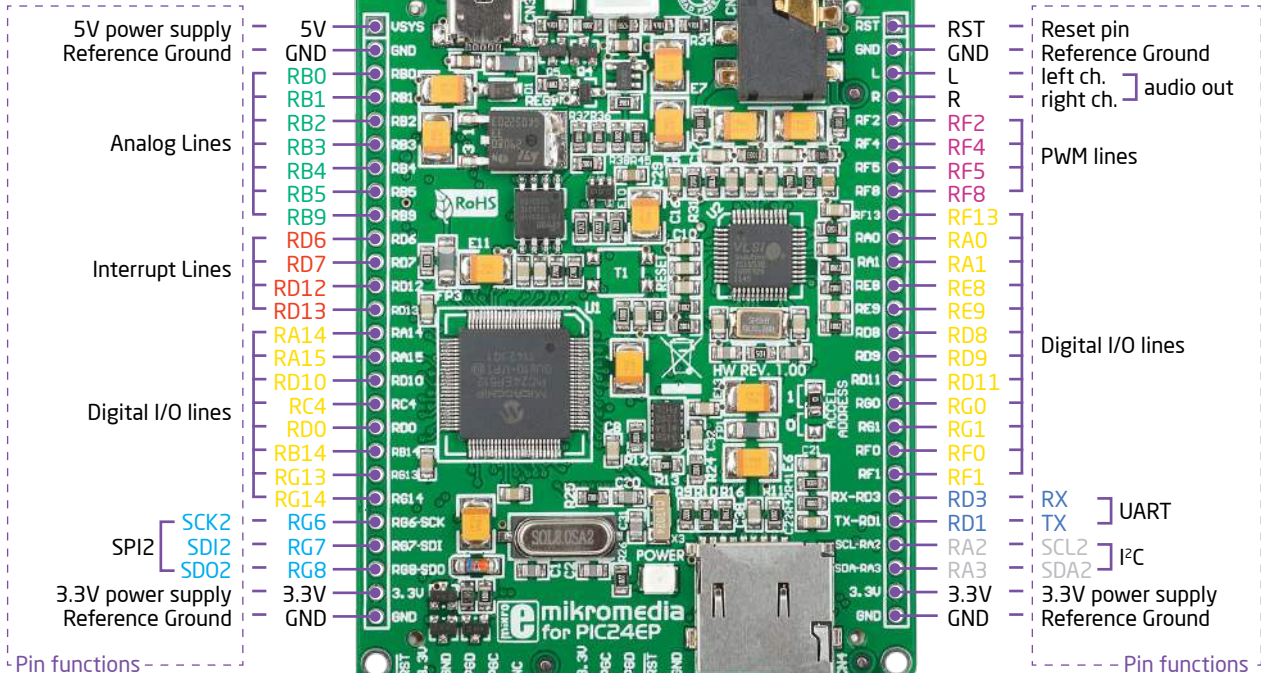

Figure 11-1:
Flash memory module



Since multimedia applications are getting increasingly demanding, it is necessary to provide additional memory space to be used for storing more data. The flash memory module enables the microcontroller to use additional **8Mbit** flash memory. It is connected to the microcontroller via the Serial Peripheral Interface (SPI).

13. Pinout



14. Dimensions

7 1.6 4
276 63 157

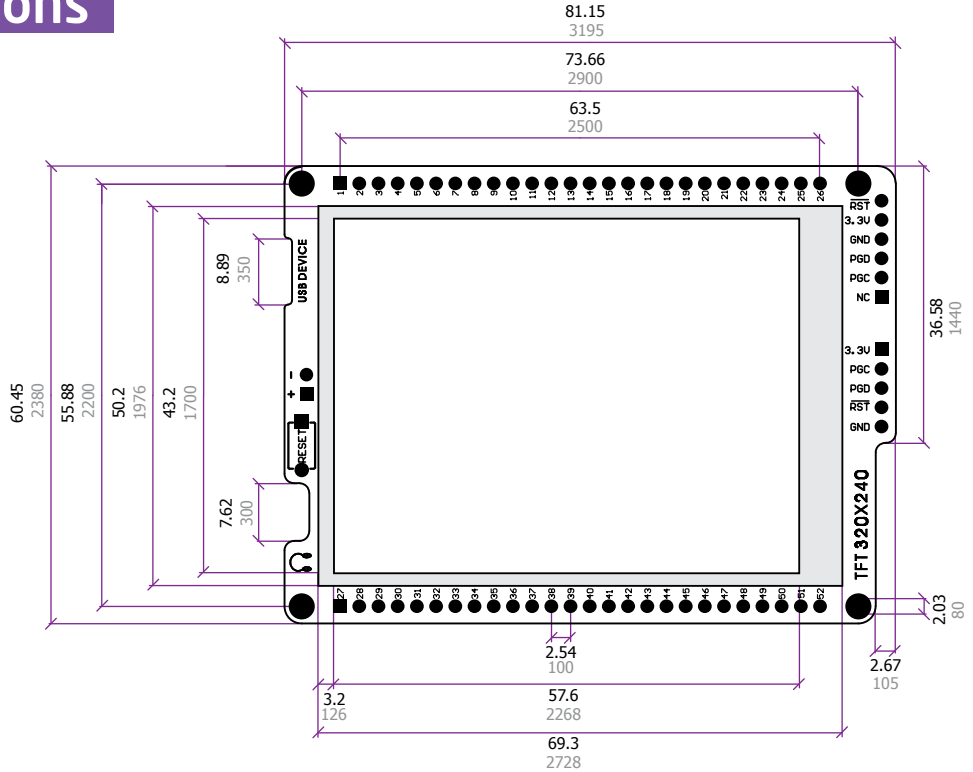
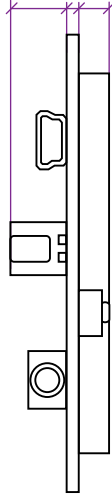

Legend

 mm
 mils

15. mikromedia accessories

We have prepared a set of extension boards pin-compatible with your mikromedia, which enable you to easily expand your board basic functionality. We call them mikromedia shields. But we also offer other accessories, such as Li-polymer battery, stacking headers, wire jumpers and more.



01 Connect shield



02 BatteryBoost shield

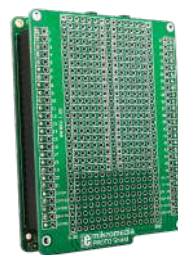

03 PROTO shield

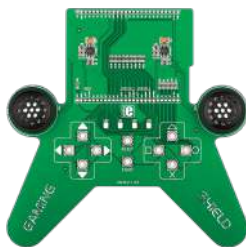

04 Gaming shield

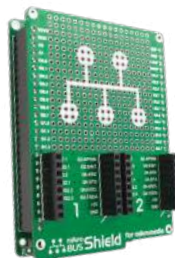

05 mikroBUS shield



06 Li-Polymer battery



07 Wire Jumpers

What's next?

You have now completed the journey through each and every feature of mikromedia for PIC24EP® board. You got to know its modules and organization. Now you are ready to start using your new board. We are suggesting several steps which are probably the best way to begin. Find useful projects and tutorials on the **Libstock** website (<http://www.libstock.com/>). Join our **Forum** (<http://www.mikroe.com/forum/>) and get help from a large ecosystem of users.

Compiler

You still don't have an appropriate compiler? Locate dsPIC/PIC24® compiler that suits you best on our site:



<http://www.mikroe.com/dspic/compilers/>

Choose between mikroC™, mikroBasic™ and mikroPascal™ and download a fully functional demo version, so you can begin building your first applications.

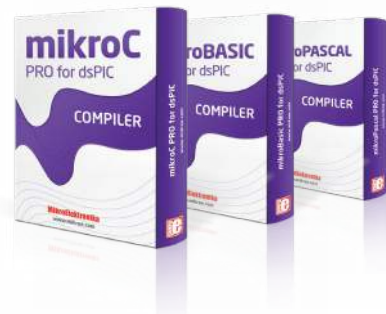

Visual TFT

Once you have chosen your compiler, and since you already got the board, you are ready to start writing your first projects. **Visual TFT software** enables you to quickly create your GUI. It will automatically generate code compatible with MikroElektronika compilers. Visual TFT is rich with examples, which are an excellent starting point for your future projects. Download it from the link below:



<http://www.mikroe.com/visualtft/>

Notes:

Notes:

DISCLAIMER

All the products owned by MikroElektronika are protected by copyright law and international copyright treaty. Therefore, this manual is to be treated as any other copyright material. No part of this manual, including product and software described herein, may be reproduced, stored in a retrieval system, translated or transmitted in any form or by any means, without the prior written permission of MikroElektronika. The manual PDF edition can be printed for private or local use, but not for distribution. Any modification of this manual is prohibited.

MikroElektronika provides this manual 'as is' without warranty of any kind, either expressed or implied, including, but not limited to, the implied warranties or conditions of merchantability or fitness for a particular purpose.

MikroElektronika shall assume no responsibility or liability for any errors, omissions and inaccuracies that may appear in this manual. In no event shall MikroElektronika, its directors, officers, employees or distributors be liable for any indirect, specific, incidental or consequential damages (including damages for loss of business profits and business information, business interruption or any other pecuniary loss) arising out of the use of this manual or product, even if MikroElektronika has been advised of the possibility of such damages. MikroElektronika reserves the right to change information contained in this manual at any time without prior notice, if necessary.

HIGH RISK ACTIVITIES

The products of MikroElektronika are not fault - tolerant nor designed, manufactured or intended for use or resale as on - line control equipment in hazardous environments requiring fail - safe performance, such as in the operation of nuclear facilities, aircraft navigation or communication systems, air traffic control, direct life support machines or weapons systems in which the failure of Software could lead directly to death, personal injury or severe physical or environmental damage ('High Risk Activities'). MikroElektronika and its suppliers specifically disclaim any expressed or implied warranty of fitness for High Risk Activities.

TRADEMARKS

The MikroElektronika name and logo, the MikroElektronika logo, mikroC™, mikroBasic™, mikroPascal™, mikroProg™, mikroBUS™, click™ boards, EasyPIC Fusion™ and mikromedia™ are trademarks of MikroElektronika. All other trademarks mentioned herein are property of their respective companies.

All other product and corporate names appearing in this manual may or may not be registered trademarks or copyrights of their respective companies, and are only used for identification or explanation and to the owners' benefit, with no intent to infringe.



If you want to learn more about our products, please visit our web site at www.mikroe.com

If you are experiencing some problems with any of our products or just need additional information, please place your ticket at www.mikroe.com/support

If you have any questions, comments or business proposals,
do not hesitate to contact us at office@mikroe.com

mikromedia for PIC24EP Manual
ver. 1.00b



0 100000 024690