

P	LTR	DESCRIPTION	DATE	DWN	APVD
	C1	ECR-13-017177	05NOV13	PKS	RRP

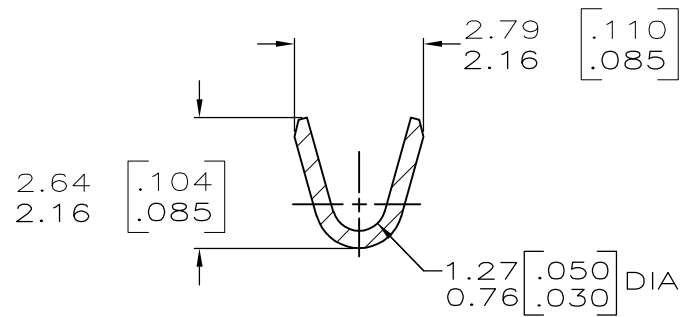

SECTION A-A  
ROTATED 90° CW  
SCALE 10:1

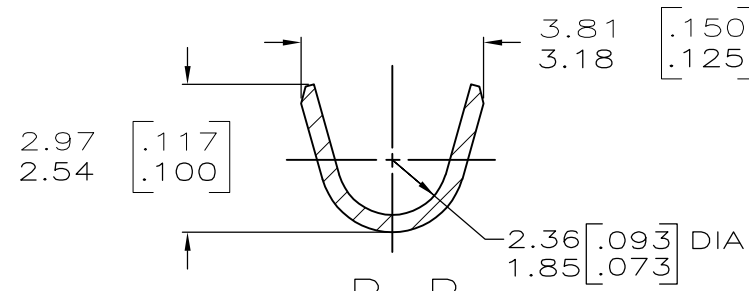

SECTION B-B  
ROTATED 90° CW  
SCALE 10:1

- 1 CONTINUOUS STRIP ON REELS (NO SPLICES) WITH TERMINALS LOCATED ON 8.38±0.08 [.330±.003] CENTERS.
- 2 SLOT ACCEPTS 0.36-0.45mm [#27-#25] AWG COPPER MAGNET WIRE 2 WIRES MAX OF THE SAME SIZE PER SLOT.
- 3 WIRE BARREL ACCEPTS 0.3-1.0mm² [#22-#18] AWG LEAD WIRE.
- 4 IDENTIFICATION NUMBER 9 FOR WIRE SLOT SIZE.
- 5 INSULATION BARREL ACCEPTS 1.80-2.23 [.071-.088] DIA INSULATION.
- 6 0.00203[.000080]-0.00381[.000150] TIN PLATE PER MIL-T-10727 OVER 0.00254[.000100]-0.00508[.000200] COPPER UNDERPLATE PER MIL-C-14550.

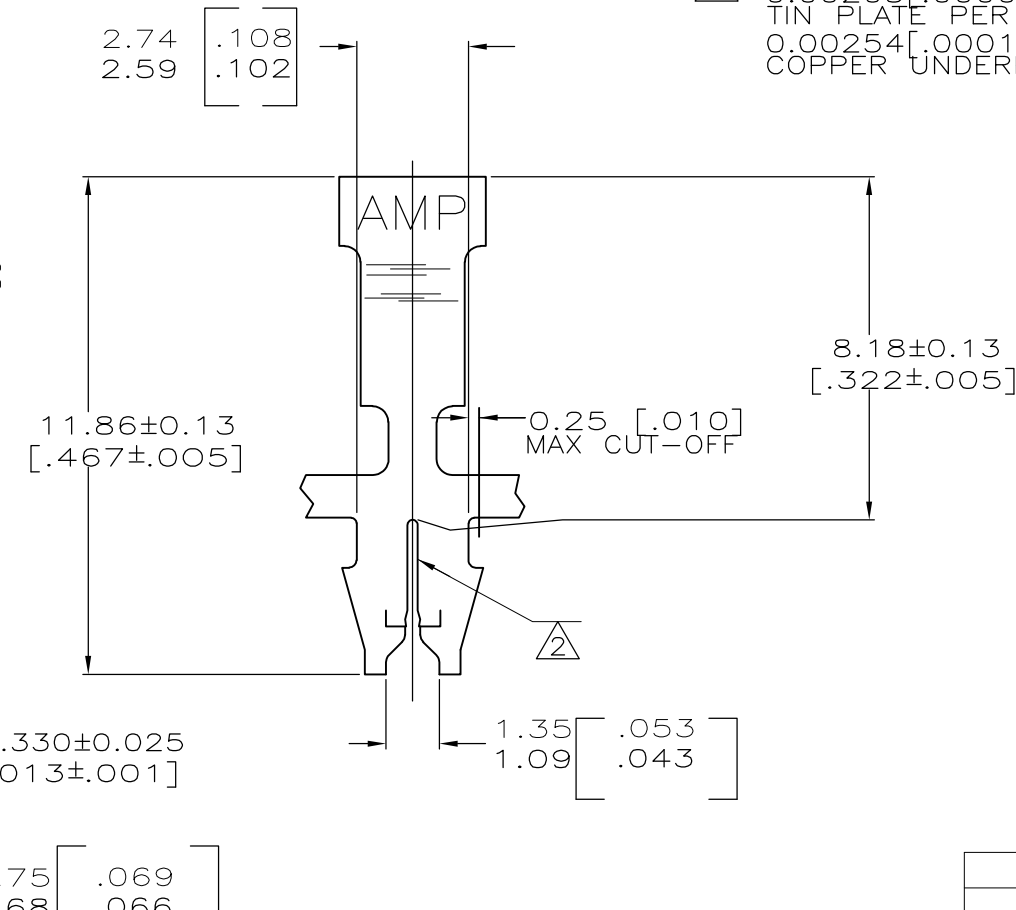
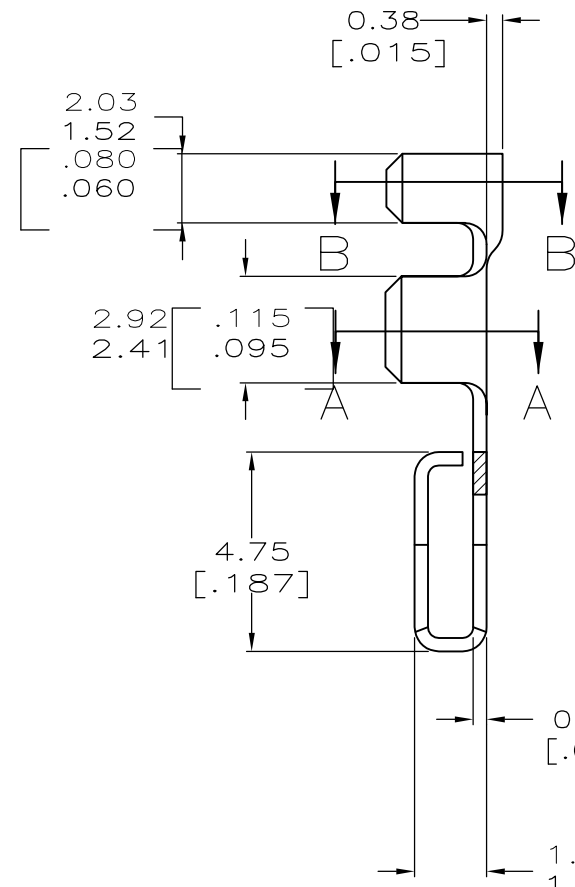
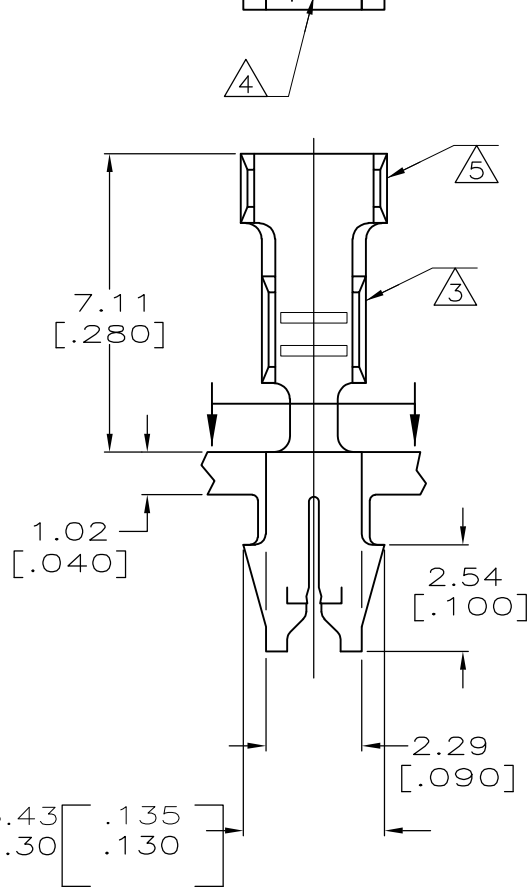
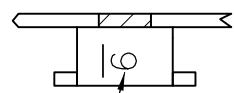

REVERSE	63856-2
STANDARD	63856-1

TYPE	WIDTH	STRIP LENGTH ±.015	TYPE	WIDTH	±.051[±.002] HEIGHT	WIRE
INSUL BARREL CRIMP	2.79 [.110]	3.56 [.140]	F	1.78 [.070]	1.08 [.043]	0.4mm[22]
					1.18 [.047]	0.5mm[20]
					1.32 [.052]	0.8mm[18]
			WIRE BARREL CRIMP			

THIS DRAWING IS A CONTROLLED DOCUMENT.

DWN MICHAEL S. FEHER 07/JUN/95  
CHK JEFF R. RUTH 08/JUN/95  
APVD -

PRODUCT SPEC 108-2012  
APPLICATION SPEC 114-2069  
WEIGHT -

MATERIAL BRASS  
FINISH 6

NAME: TERMINAL, F-CRIMP, MAG-MATE™  
SIZE: A3  
CAGE CODE: 00779  
DRAWING NO: C-63856  
RESTRICTED TO: -

SCALE: 8:1  
SHEET: 1 OF 1  
REV: C1

CUSTOMER DRAWING