

Battery Switch 12V - System Demonstrator

User Guide

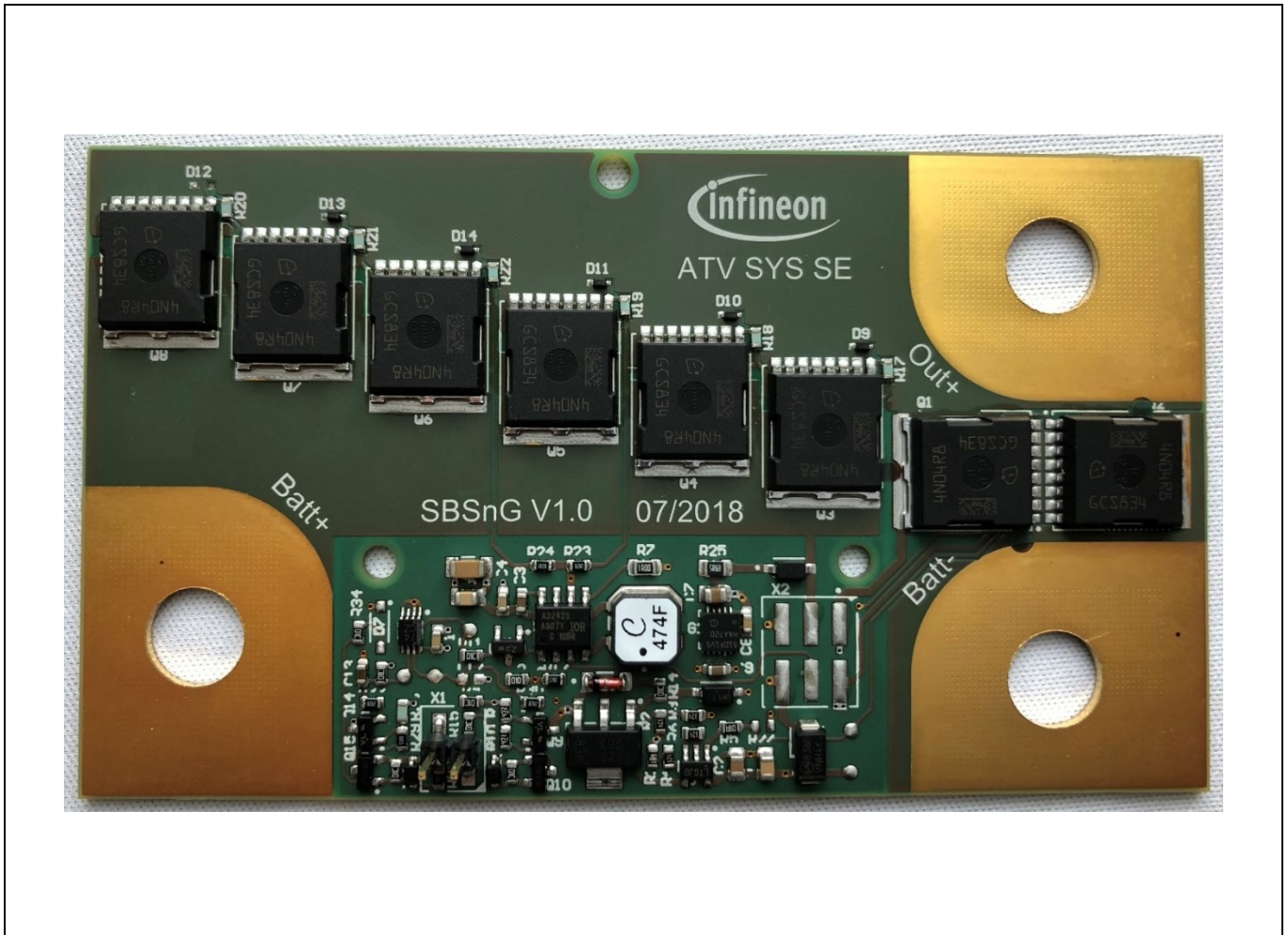

About this document

Scope and purpose

This board user manual provides a short introduction to the Battery Switch 12V System Demonstrator and its application.

Intended audience

Electrical engineers who are qualified and familiar with the challenges of handling high current circuits as well as automotive relays or solid-state switches.

Important notice**Important notice**

The Evaluation Boards and Reference Boards as well as the information in this document are solely intended to support designers of applications in evaluating the use of products from Infineon Technologies for their intended applications.

Environmental conditions have been considered in the design of the Evaluation Boards, Reference Boards and the like provided by Infineon Technologies. The design of the Evaluation Boards and Reference Boards has been tested by Infineon Technologies only as described in this document. The design is not qualified in terms of safety requirements, manufacturing and operation over the entire operating temperature range or lifetime.

The Evaluation Boards and Reference Boards provided by Infineon Technologies are subject to functional testing only under typical load conditions. Evaluation Boards and Reference Boards are not subject to the same procedures as regular products regarding returned material analysis (RMA), process change notification (PCN) and product discontinuation (PD).

Evaluation Boards and Reference Boards are not commercialized products, and are solely intended for evaluation and testing purposes. In particular, they shall not be used for reliability testing or production. The Evaluation Boards and Reference Boards may therefore not comply with CE or similar standards (including but not limited to the EMC Directive 2004/EC/108 and the EMC Act) and may not fulfill other requirements of the country in which they are operated by the customer. The customer shall ensure that all Evaluation Boards and Reference Boards will be handled in a way which is compliant with the relevant requirements and standards of the country in which they are operated.

The Evaluation Boards and Reference Boards as well as the information provided in this document are addressed only to qualified and skilled technical staff, for laboratory usage, and shall be used and managed according to the terms and conditions set forth in this document and in other related documentation supplied with the respective Evaluation Board or Reference Board.

It is the responsibility of the customer's technical departments to evaluate the suitability of the Evaluation Boards and Reference Boards for the intended application, and to evaluate the completeness and correctness of the information provided in this document with respect to such application.

The customer accepts that the Evaluation Boards and Reference Boards are not intended to be used in life-endangering applications such as medical, nuclear, military, life-critical or other applications, where failure of the Evaluation Boards and Reference Boards, or any results from the use thereof, can reasonably be expected to result in personal injury.

The Evaluation Boards and Reference Boards and any information in this document is provided "as is" and Infineon Technologies disclaims any warranties, express or implied, including but not limited to warranties of non-infringement of third party rights and implied warranties of fitness for any purpose, or for merchantability.

Infineon Technologies shall not be responsible for any damages resulting from the use of the Evaluation Boards and Reference Boards and/or from any information provided in this document. The customer is obliged to defend, indemnify and hold Infineon Technologies harmless from and against any claims or damages arising out of or resulting from any use thereof.

Infineon Technologies reserves the right to modify this document and/or any information provided herein at any time without further notice.



Table of contents

About this document..... 1

Important notice 2

Table of contents..... 3

1 Overview 4

2 Connecting the Switch 6

2.1 Pin Assignment..... 7

2.2 Input Voltage Range of Control Pins X1 8

3 Operating Conditions 9

3.1 Voltage Rating and Current Consumption 9

3.2 Current Carrying Capability and Thermal behaviour..... 11

4 Switching Behaviour14

4.1 Setup..... 14

4.2 Basic switching behaviour 15

4.3 Approximation of avalanche losses..... 17

4.3.1 Example calculation for the Battery Switch 12V System Demonstrator..... 18

4.3.2 Simulated Safe Operating Areas at different Battery Configurations..... 18

5 Mechanical Dimensions20

6 Schematics21

7 PCB Description26

7.1 PCB Technology 26

7.2 PCB Layout 27

8 Bill Of Materials30

9 References31

Revision History32

Overview

1 Overview

The Battery Switch 12V System Demonstrator shows a semiconductor-based solution of a unidirectional battery master switch for automotive electrical systems with active or passive freewheeling feature.

Note: This demonstrator does not cover all aspects of diagnostics. Its focus lies solely on the switching element and the demonstration of the current carrying and short circuit handling capabilities.

The demonstrator consists of six MOSFETs with very low on resistance ($R_{DS(on)}$) connected in parallel. The switches are mounted on a structured 1 mm copper inlay board 2.0, manufactured by [Schweizer Electronic AG](#). For more information see section 7.1. A gate driver circuitry for controlling the ON and OFF states of the MOSFETs is also embedded in the demoboard circuitry. The top and bottom views of the PCB board are illustrated in Figure 1 and Figure 2. Two additional MOSFETs are used to implement active freewheeling and reverse polarity protection features on the board.

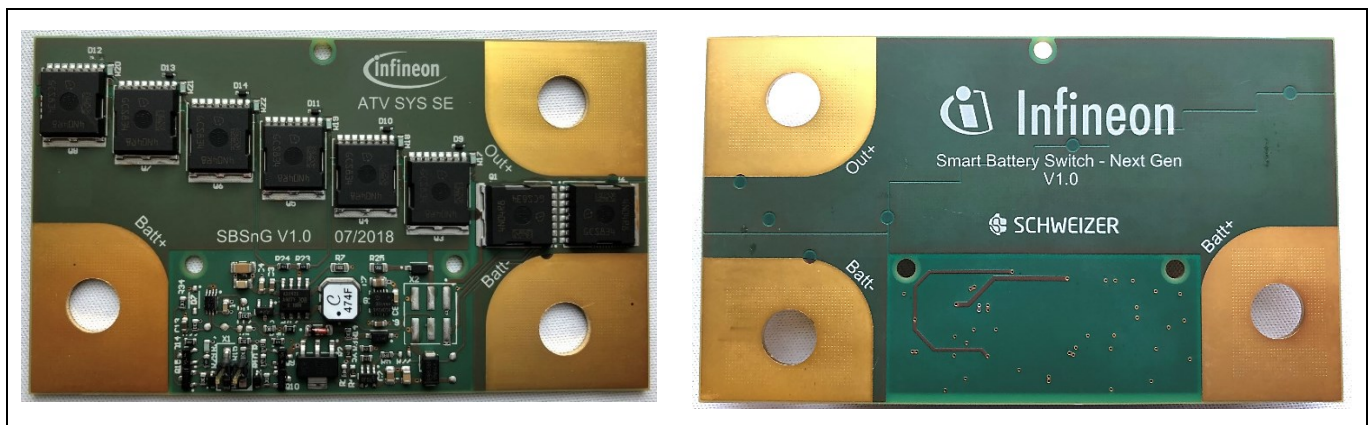

Figure 1 Top View

Figure 2 Bottom View.

The main components used for the Battery Switch 12V System Demonstrator are listed in Table 1.

Table 1 Main Components

Component	Type	Comment
MOSFETs (6x)	IPLU300N04S4-R8	300 A, 40 V, 0.53 mOhm typ.
MOSFET	IPLU300N04S4-R8	Active/Passive Freewheeling
MOSFET	IPLU300N04S4-R8	Reverse Polarity Protection
Gate Driver	AUIR3242S	Input latched through Flip Flop, initial state after power up is normally on

Thanks to the low ohmic MOSFETs, the typical on state resistance of the whole switch is less than 160 $\mu\Omega$, measuring from the positive battery terminal to output terminal at room temperature. The six parallel MOSFETs account for typically 88 $\mu\Omega$ at room temperature. At 120°C board temperature and 500 A current this value will increase to roughly 125 $\mu\Omega$.

Please note that the 12 V Battery Switch Demonstrator is a unidirectional switch. This means that it will interrupt current flowing from the battery to the load but not current flowing into the battery. The reason for this is the intrinsic body diode of the power MOSFETs as shown in Figure 3. Therefore, charging through the MOSFETs should be avoided or at least limited to currents below 20 A when the switch is deactivated (off).

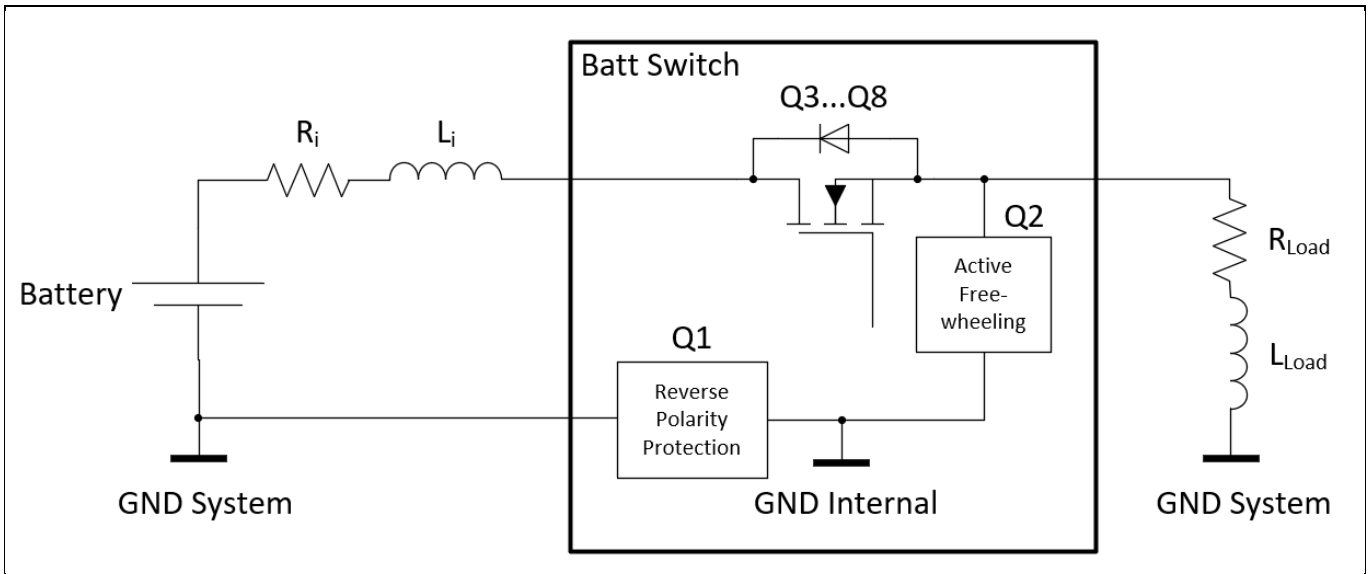

Figure 3 Block Diagram of Unidirectional Switch due to MOSFET Body Diode

In Figure 3 the block diagram of the battery switch is given. R_i and L_i are lumped elements for resistance and inductance connected to the input terminal of the battery switch. They are the result of the internal construction of the battery and the cabling to the switch. R_{Load} and L_{Load} are lumped elements which represent the load connected to the output terminal of the battery switch.

The internal GND is protected against reverse polarity connection through a MOSFET added in the GND Path. The active freewheeling feature is implemented through a MOSFET between “GND Internal” and “Out+”. In Figure 27 in chapter 6 a detailed description of the circuitry responsible for reverse polarity protection and active freewheeling is shown.

2 Connecting the Switch

In this chapter the control of the 12 V Battery Switch Demonstrator is discussed. There is only one assembly option for 12 V electric systems with active freewheeling feature available. The switch shall be connected between battery and load as pictured in Figure 4.

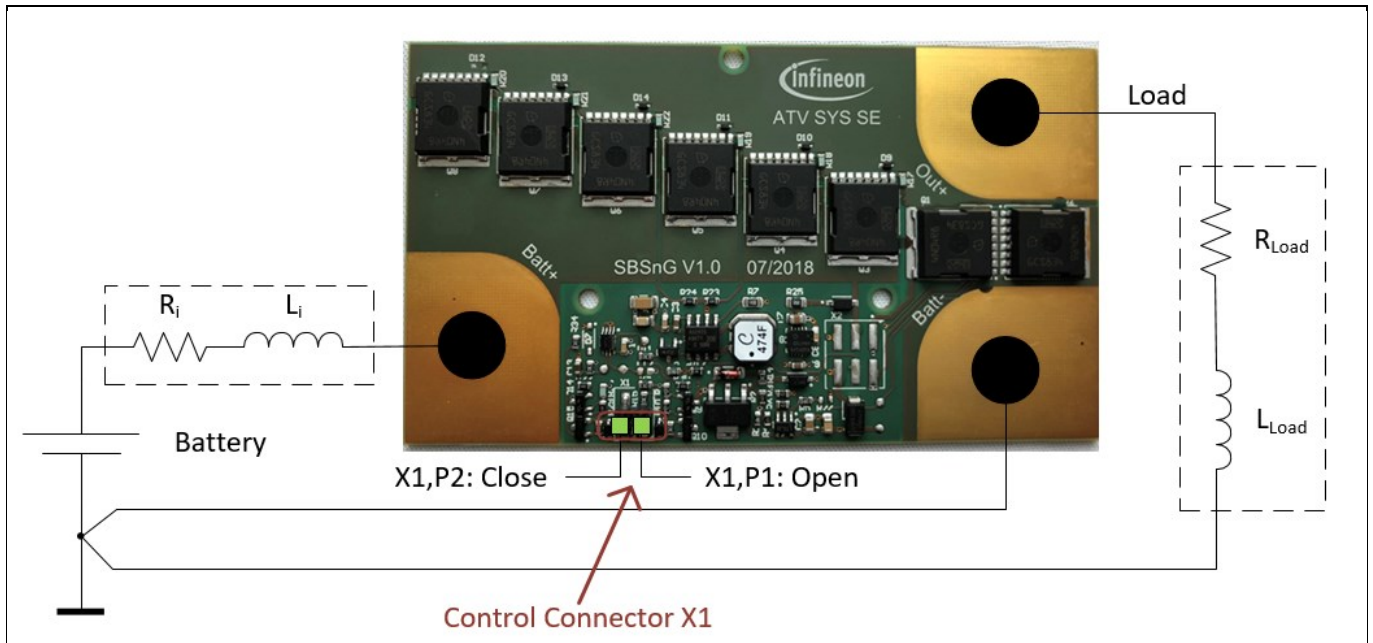

Figure 4 Basic Connection Diagram

During a shut off event, the energy which is stored in the inductances of the circuitry need to be released via avalanche and freewheeling.

The energy which is stored in L_{Load} behind the MOSFETs will decay by freewheeling through the active freewheeling circuitry. Energy which is stored in L_i and energy which is fed by the battery will be dissipated to heat through an avalanche event in the MOSFETs [1]. Make the connection from battery poles to the Battery Switch 12V System Demonstrator as short as possible. This will keep the total inductance L_i and total resistance R_i in front of the switching MOSFETs as small as possible.

In chapter 3, the operating conditions and the thermal behaviour of the Battery Switch 12V System Demonstrator are shown. A description to change from active freewheeling to passive freewheeling is given.

More information about the switching behaviour and switching constraints can be found in chapter 4.

Mechanical dimensions of the board and mounting holes can be found in chapter 5. Furthermore the schematic, PCB design and technology as well as the bill of materials are discussed in chapter 6, 7 and 8.

Connecting the Switch

2.1 Pin Assignment

In Figure 5 the control logic of the Battery Switch 12V System Demonstrator is shown. The initial state of the battery switch is conducting, after connecting it to the voltage of the battery, it is normally on like a pyro-electric fuse. The switch is controlled by logic pulses on Header X1. It is a standard 2-pin single row 2.54 mm header (Samtec, TSM-102-01-T-SV).

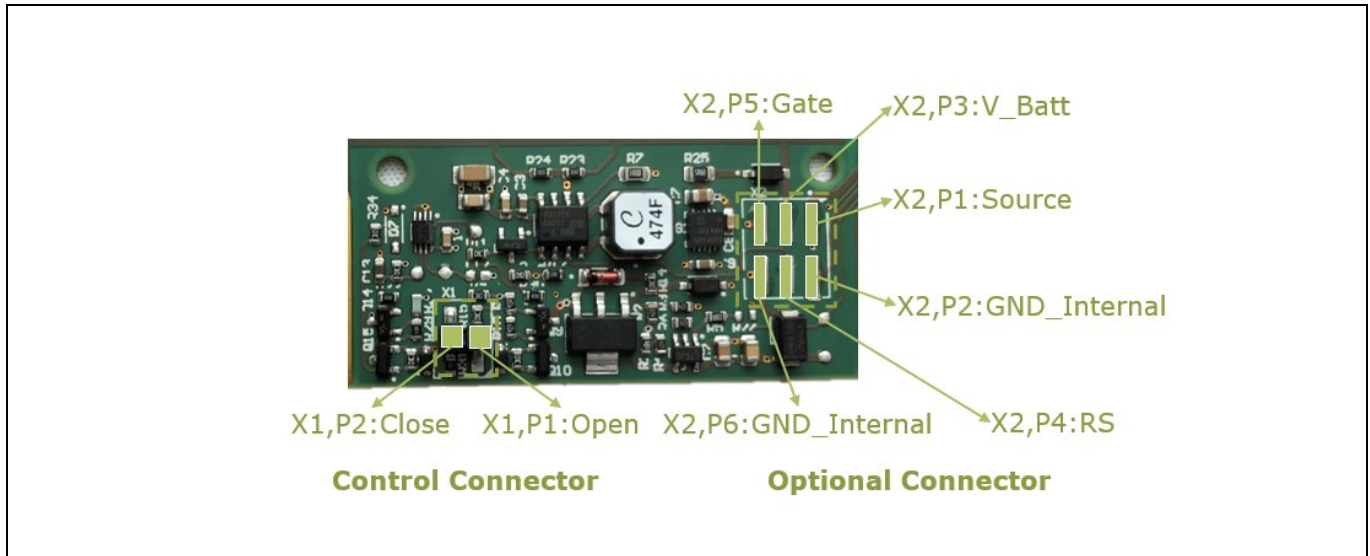

Figure 5 Pin Assignment of Control Connector X1 and Optional Connector X2

Table 2 and Table 3 are showing the pin description and the truth table of the Battery Switch 12V System Demonstrator respectively. The corresponding states of the battery switch are latched through a D-type flip-flop.

Table 2 Description of X1 Connector

Pin	Name	Function
X1,P1	Open	Positive Pulse disconnects the battery from the load ⁽¹⁾
X1,P2	Close	Positive Pulse resets the switch and connects battery with the load ⁽¹⁾

1) Min. Pulswidth = 100 us; Max. Frequency = 1 Hz, Continuous high level on the inputs should be avoided.

Table 3 Logic Table of X1

Open	Close	12 V Battery Switch Demonstrator
LOW	LOW	Unchanged
LOW	HIGH	ON
HIGH	LOW	OFF
HIGH	HIGH	OFF

Connecting the Switch

There is a second connector placed on the board. Via this connector it is possible to measure additional signals on the Battery Switch 12V System Demonstrator (see Table 4). It is a standard 6-pin dual row 2.54 mm header (Samtec, TSM-103-01-T-DV).

Table 4 Descripton of X2 Connector

Pin	Name	Function
X2,P1	Source	Source potential of switching MOSFETs (Q3...Q8)
X2,P2	GND_Internal	Reverse polarity protected GND, see Figure 3
X2,P3	V_Batt	Drain potential of switching MOSFETs (Q3...Q8)
X2,P4	RS	Analog Diagnostic Pin of AU1R3242S
X2,P5	Gate	Gate output of AU1R3242S
X2,P6	GND_Internal	Same Level as GND_Internal

2.2 Input Voltage Range of Control Pins X1

The input will accept a very wide input voltage range. Therefore, it is possible to drive the switch with 5 V logic as well as directly from the battery voltage.

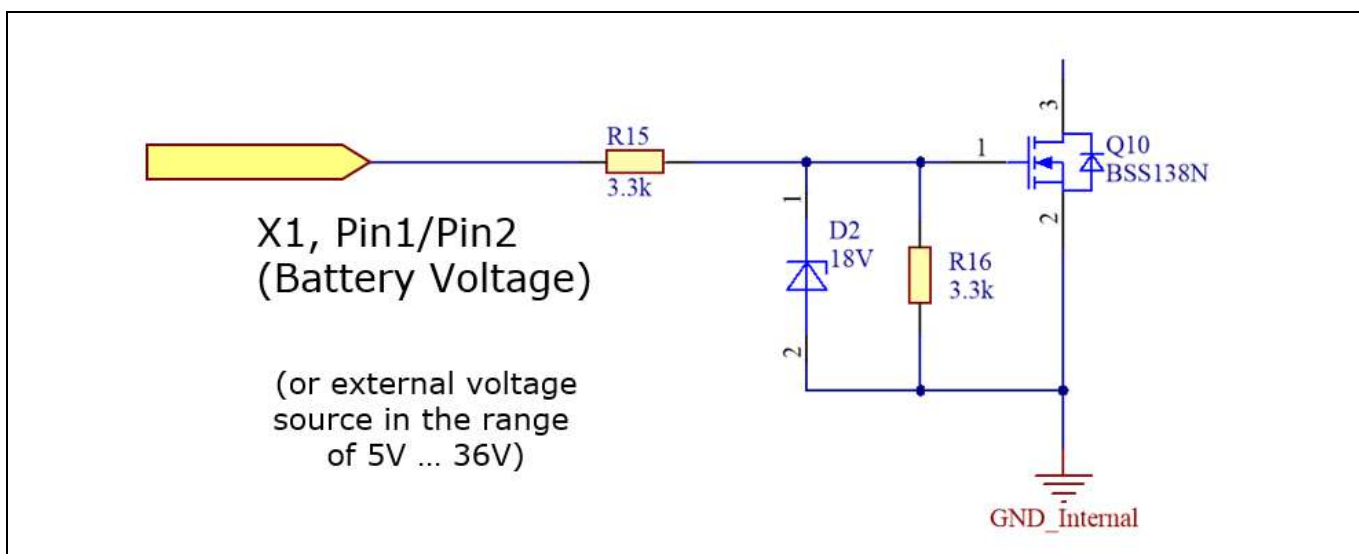

Figure 6 Input Stage

3 Operating Conditions

3.1 Voltage Rating and Current Consumption

Figure 7 shows the operating range of the 12 V Battery Switch Demonstrator. The nominal operating voltage for the Demonstrator is 7 V to 18 V. It is activated by connecting a voltage higher than 7V to its input terminals “Batt+” and “Batt-“. If the electric system is facing an undervoltage, the switch stays on until the voltage is falling below 3 V. During undervoltage condition, the 12 V Battery Switch Demonstrator can be deactivated at any time. It is not possible to activate the switch in the range of undervoltage, to do so, the voltage of the electric system needs to be guided back to the operating range. The switch can handle small overvoltage events, no permanent operation in the overvoltage range is allowed.

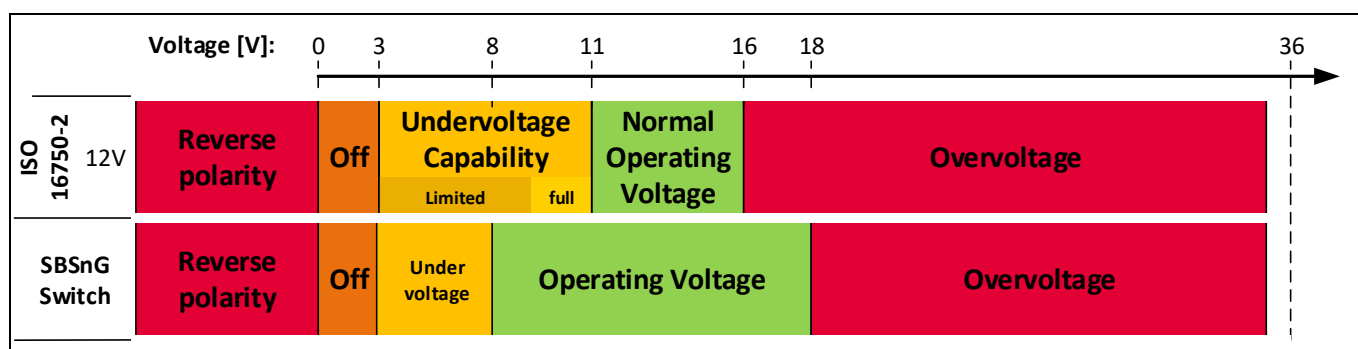

Figure 7 Operating Voltage Range

The 12 V Battery Switch Demonstrator is delivered with active freewheeling feature assembled. It has a maximum current consumption of 370 μA in on state and 490 μA in off-state. The current consumption of the 12 V Battery Switch Demonstrator is caused mainly by the comparator circuit for active freewheeling detection. See Table 5 for more information about typical current consumption of each device in on state.

Table 5 Current consumption per device

Device	Typ. current consumption in on state
AUIR3242S	35 μA
LT6015	315 μA
74LVC2G74	0.1 μA

The current consumption of the 12 V Battery Switch Demonstrator can be further reduced, if the active freewheeling circuitry is removed. To do so R1 ... R6 and U1 needs to be removed and R27 needs to be placed on the board, to short Gate and Source of the Freewheeling MOSFET Q1. Figure 8 is depicting which rework is needed to change to passive freewheeling.

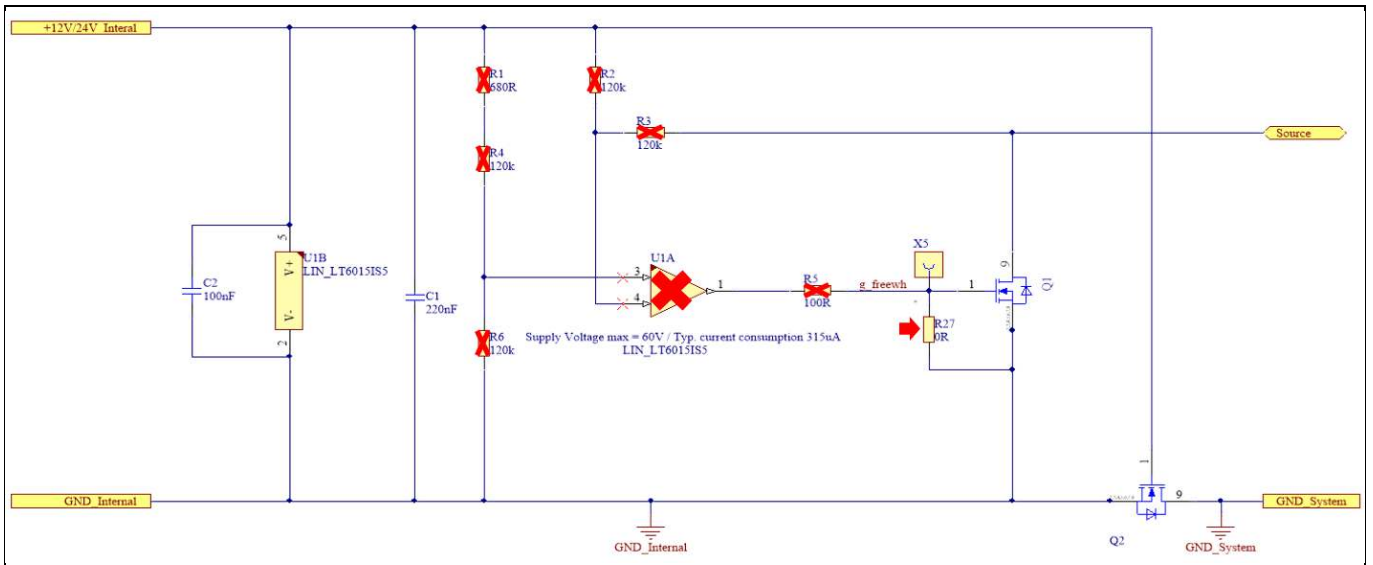

Figure 8 Changes needed going from active to passive freewheeling

Figure 9 is showing the difference in current consumption for both freewheeling options. For passive freewheeling the maximum current consumption in on state is about 54 μA and in off state 110 μA .

Note: Passive freewheeling is increasing the amount of energy which is decayed inside MOSFET Q1. If this feature is assembled, the user needs to take special care about this amount of energy. Which means, inductance, switch off current or operating temperature needs to be limited. It is recommended to stay inside the SOA of the MOSFET, for more information consult the data sheet [2].

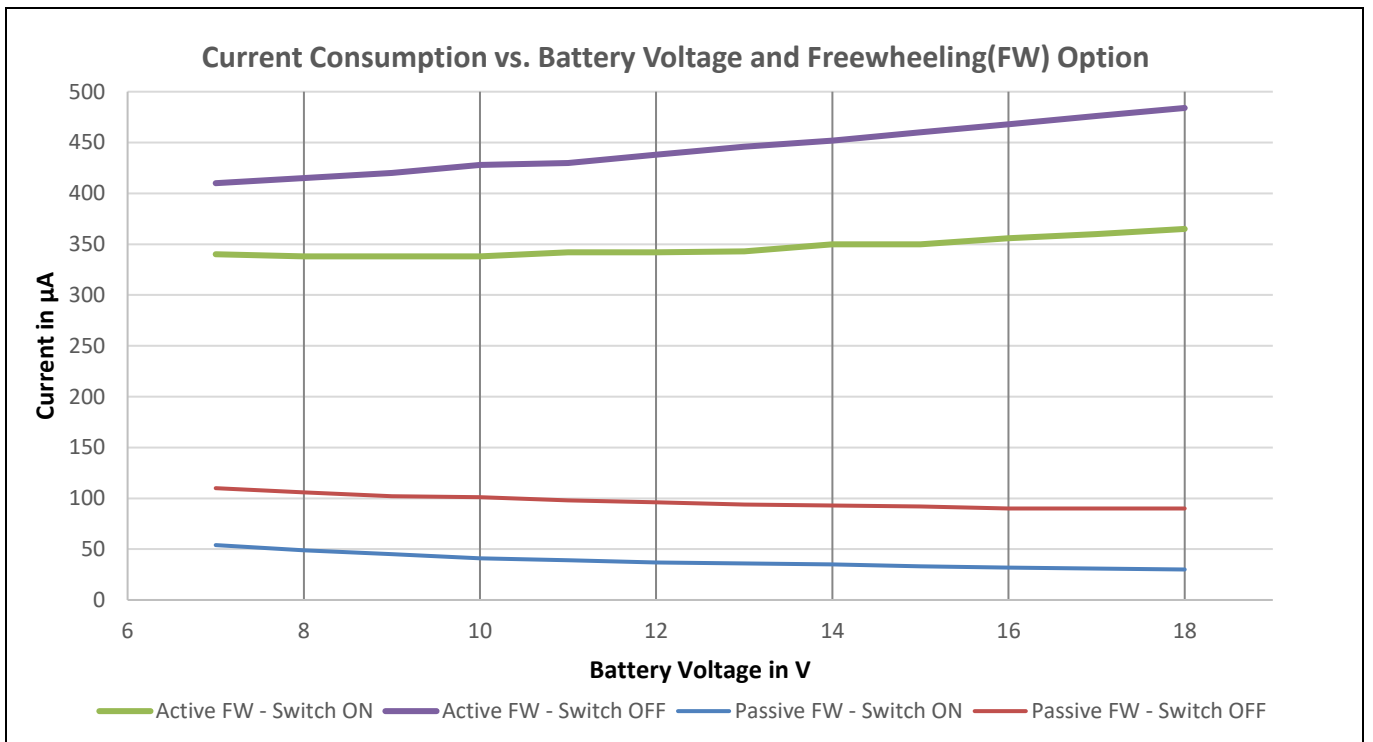

Figure 9 Current Consumption vs. Battery Voltage

3.2 Current Carrying Capability and Thermal behaviour

The switch is designed to handle peak currents up to 1800 A. However, due to the on-state resistance of the battery switch (160 $\mu\Omega$ typ. at 120°C) high currents will lead to significant power dissipation and a temperature increase in the MOSFETs. The chip can handle a maximum junction temperature of 175°C. Therefore, the maximum allowable duration for high currents is limited depending on the cooling conditions. The values in Table 6 are measured for the board exposed to a small air flow velocity of approximately 30 cm/s. and a start temperature of 25°C.

Table 6 Current Carrying Capability Estimation @ 25°C Ambient Temperature, 70 mm² Cables

Current	Power Dissipation	Duration
300 A	~ 15 W	Continuous
500 A	~ 40 W	~ 15 min.
700 A	~ 80 W	~ 2 min.

The thermal measurement setup can be found in Figure 10 and Figure 11. The package temperature of each switching MOSFET was measured with a thermocouple. Also, the input and output terminals, as well as the temperatures of the cables, in distance of 40 cm were measured. This was done to estimate the rate of heat flow, which can be used as a starting point for thermal simulations.

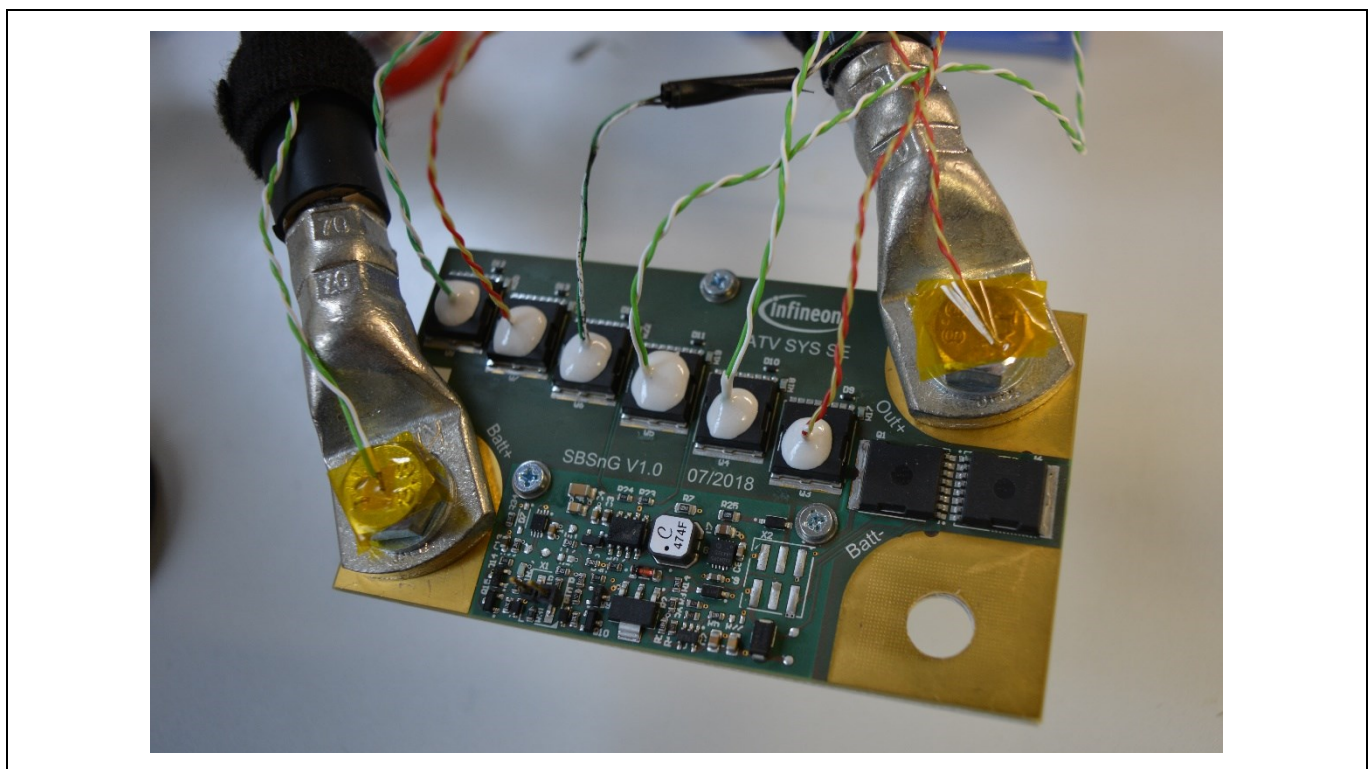

Figure 10 Temperature measurement setup

Note: Values shown in this chapter are measured under lab conditions and will vary for different cooling setups.

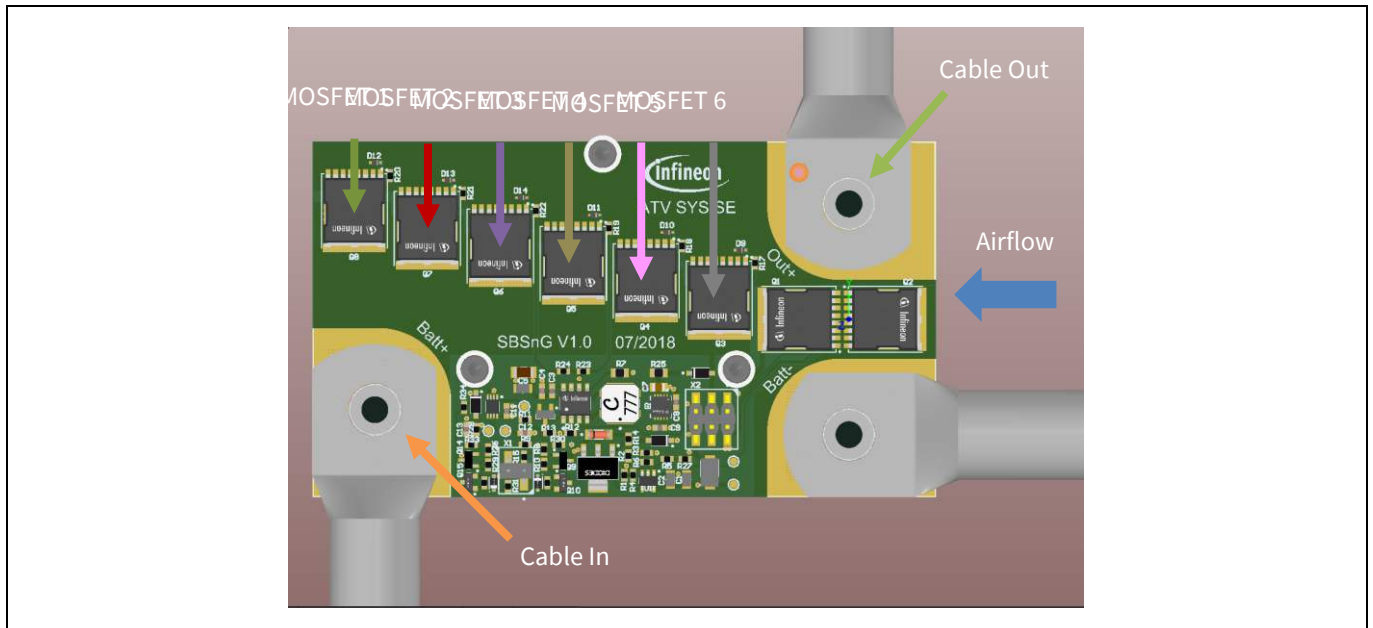

Figure 11 Temperature measurement setup

Results of the thermal measurements can be found in Figure 12 to Figure 14. For 300 A continuous current conduction MOSFET 3 to MOSFET 5 have around 58°C on top of the mold compound after 27 min of continuous conduction, see Figure 12 for detailed information.

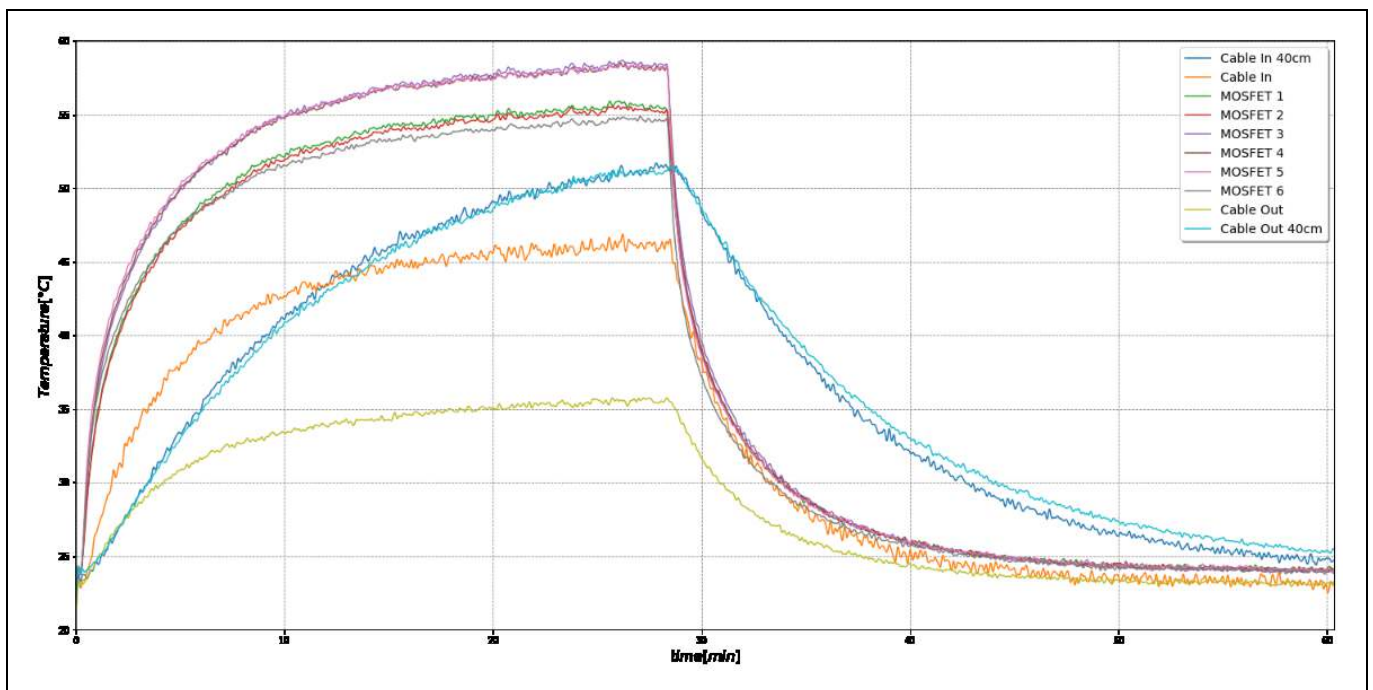

Figure 12 Temperature measurement for 300 A and 30 cm/s airflow velocity

Figure 13 is showing the results for 500 A continuous current conduction. The inner MOSFETs are passing the 140°C after 17 min, at that time the current conduction was stopped to prevent the switch from overheating.

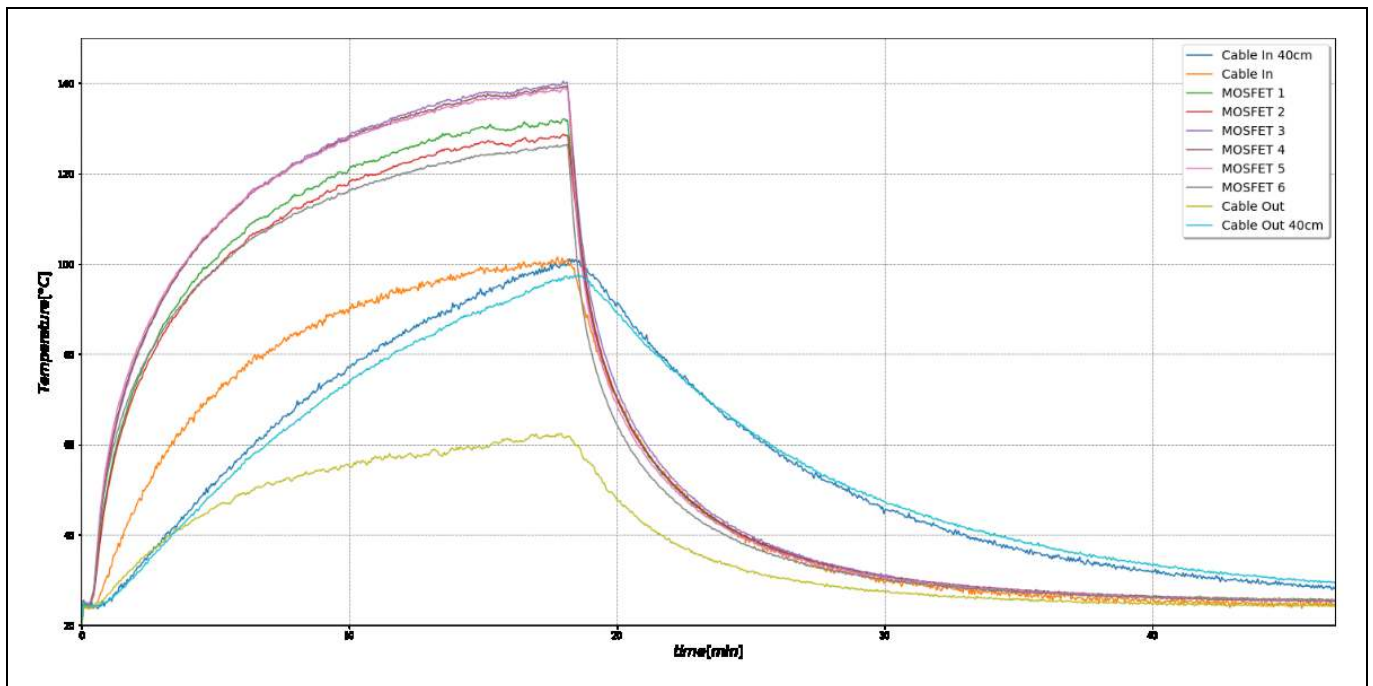

Figure 13 Temperature measurement for 500 A and 30 cm/s airflow velocity

At about 700 A continuous current conduction, the 12 V Battery Switch Demonstrator was able to handle it for ~2 min.

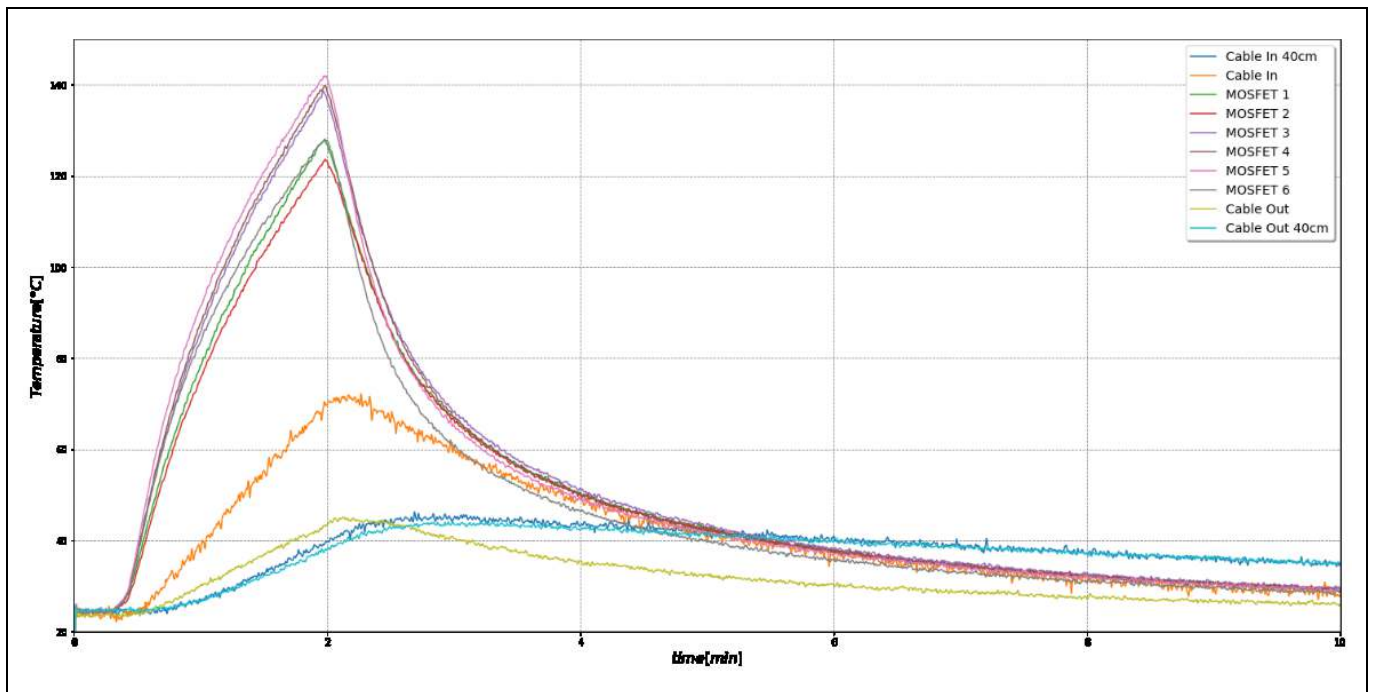

Figure 14 Temperature measurement for 700 A and 30 cm/s airflow velocity

4 Switching Behaviour

4.1 Setup

In contrast to relays, MOSFETs are switching much faster and cleaner. There is no bouncing of contacts and no arcing. Switching just takes microseconds instead of several milliseconds. This is a big advantage because short circuits can be switched off before high currents are flowing through the electrical system.

For the test setup, a battery voltage of 12 V and a L_{LOAD} of 6 μ H was used. To create a short circuit, a separated MOSFET-Switch was used as R_{LOAD} which got triggered by the output 1 of an arbitrary waveform generator (AWG), **Output 1 AWG**. The Signal **Output 2 AWG** triggers the 12 V Battery Switch Demonstrator and therefore breaks the circuit. Both control signals were referenced to the star point of the ground connection of the system. With the Delay between **Output 1 AWG** and **Output 2 AWG** the maximum switch off circuit current can be set.

Note: The Battery Switch 12V System Demonstrator has no overload, overcurrent or overtemperature detection implemented, a high switch off energy could destroy the MOSFETs. It is recommended to stay inside the SOA of the MOSFETs [2]. The switch off energy is dependent on the switch off current and the intrinsic resistances and inductances of the power distribution network.

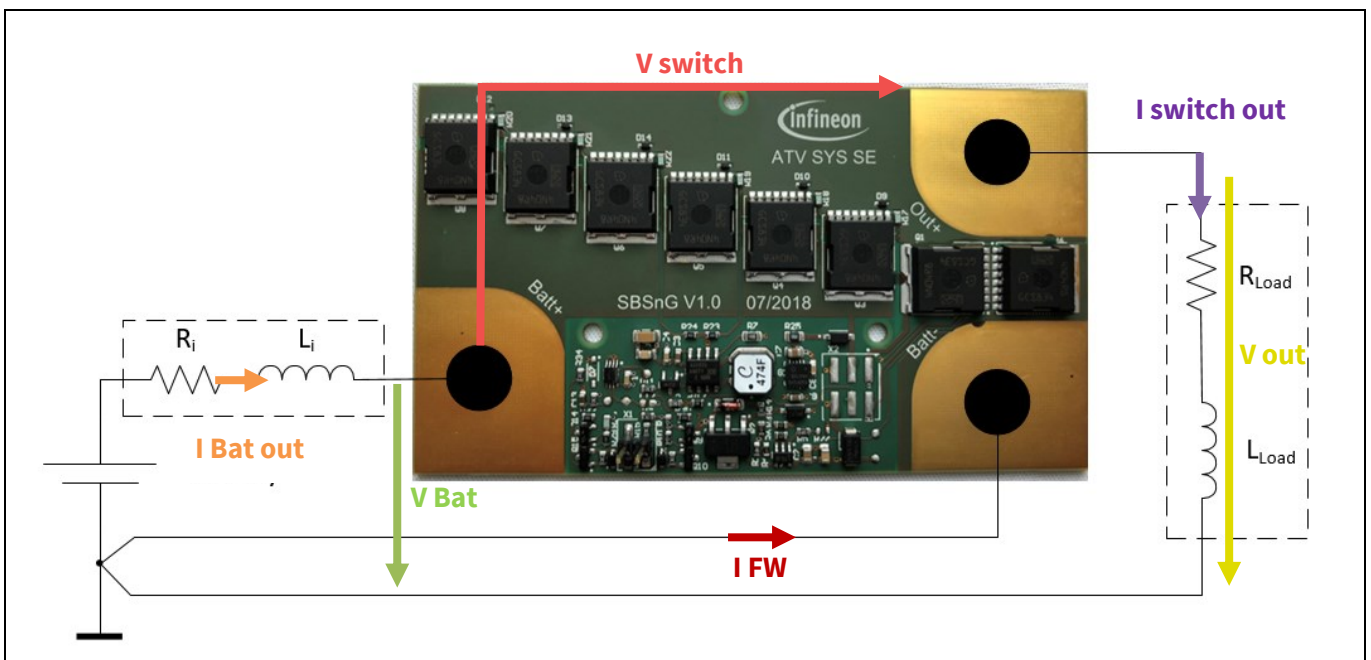

Figure 15 Measured Voltages and Currents

Figure 15 explains where the measurement probes are connected in the setup. The following waveforms in Figure 16 show the switching behaviour of the Battery Switch 12V System Demonstrator with the AUIR3242S driver. [3]

Switching Behaviour

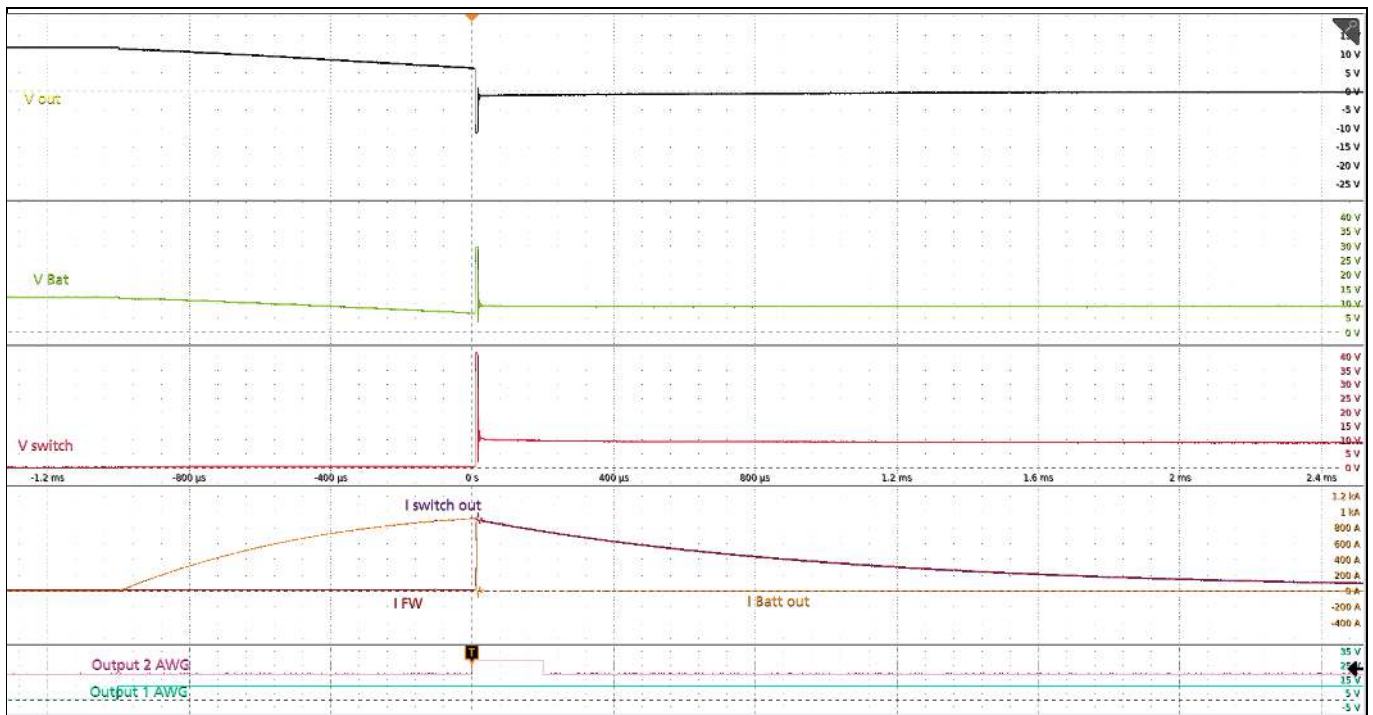

Figure 16 Switch Timing – On and Off 4 ms horizontal timespan

4.2 Basic switching behaviour

Please note that **V switch** shows the drain source voltage across the MOSFETs, so a small voltage means the switch is on (conducting) and a high voltage means the switch is off (blocking).

The delay between the occurrence of the short (Rise of **Output 1 AWG**) and the break of the circuit (Rise of **Output 2 AWG**) is responsible for the rise of the current going through the Switch. As soon as the short of the circuit occurs, the rise of the current can be approximated by the step-response of a RL-Network.

$$i_L(t) = \frac{U_{Bat}}{R_i + R_{Load}} \left(1 - e^{-\frac{t}{\tau}} \right) \text{ with } \tau = \frac{L_i + L_{Load}}{R_i + R_{Load}}$$

Equation 1

As you can see in Figure 16 the Battery Switch 12V System Demonstrator was blocked at about 900 A. The maximum current going through the switch is limited to $i_{max} = \frac{U_{Bat}}{R_i + R_{Load}}$. For this specific system configuration (R_{LOAD}, L_{LOAD}) it takes approximately 3.5 ms for the 900 A to reduce to zero.

The delay between the input signal **Output 2 AWG** and the 12 V Battery Switch Demonstrator actually breaking the circuit is caused by the input circuitry (~9 μs), see Figure 17.

When the 12 V Battery Switch Demonstrator switches off, the current delivered by the Battery (**I Bat out**) decreases rapidly. Therefore, the current going through the freewheeling diodes (**I FW**) increases, as L_{LOAD} keeps pushing current through the electrical system. The rise of **I FW** is almost identical to the fall of **I Bat out** and only limited by the parasitic inductance and resistance between the “Batt-“terminal of the 12 V Battery Switch Demonstrator and the negativ terminal of the battery. As a result, **I switch out** decreases slightly faster during the switching process as shown in Figure 17. Afterwards **I switch out** decreases the same way as **I FW** does.

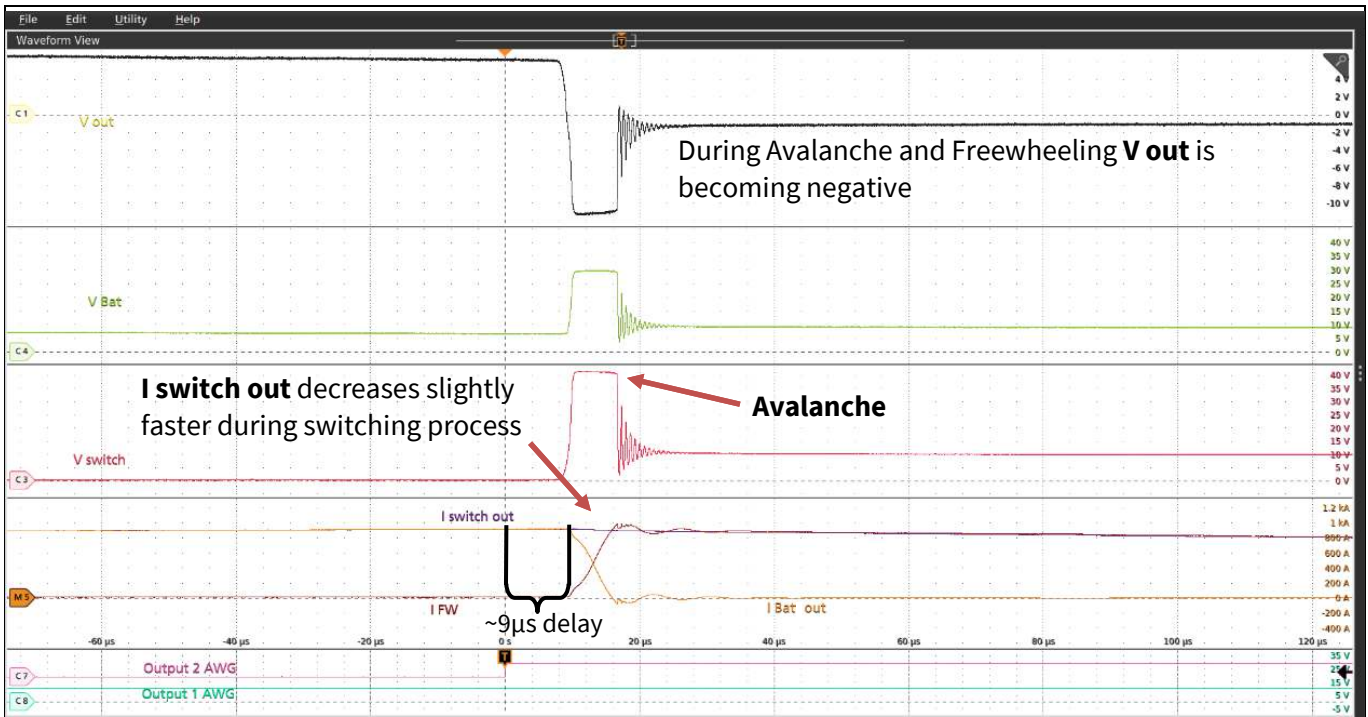

Figure 17 Switch Timing – On and Off 200 µs timespan

Figure 17 shows that after triggering the switch **V out** reaches about -13 V due to the inductance of the load L_{LOAD} . When the current flow through L_{LOAD} is interrupted it induces a voltage that pulls **V out** below ground potential. The same happens to **V Bat** with the induced voltage across L_i pulling **V Bat** to about 30 V. As a result, the voltage across the 12 V Battery Switch Demonstrator (**V switch**) rises to 43 V.

The energy stored in L_{LOAD} is released by the MOSFET used as active free wheeling diode. Energy stored in L_i gets released by the avalanche breakdown of the six MOSFETs. This happens when **V switch** reaches the avalanche breakdown voltage of the MOSFETs, which is about $(1.2 \dots 1.5) \times V_{BRDSS}$. V_{BRDSS} is the drain-source breakdown voltage of the MOSFET [1]. In this case the V_{BRDSS} is between 48 V and 60 V respectively, which is higher than the measured voltage of 43 V. An explanation for that can be found in Figure 18. **V switch** was measured between input terminal “Batt+” and output terminal “Out+”, during the switch off event the internal PCB Inductances are working against the V_{BRDSS} . If it is measured directly at the MOSFET Terminal V_{BRDSS} of ~49 V can be seen.

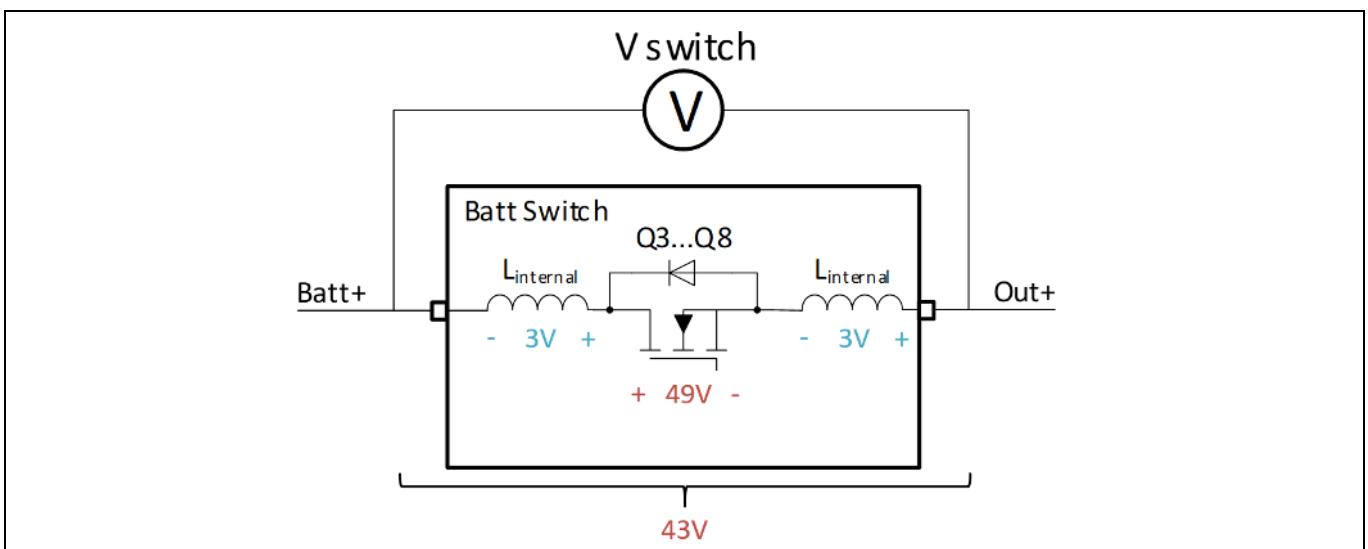

Figure 18 Parasitic switch inductances are lowering the measured V switch voltage.

4.3 Approximation of avalanche losses

The avalanche of the MOSFETs occurs when the 12 V Battery Switch Demonstrator breaks the circuit and L_i keeps pushing the current through the switch and therefore the voltage across L_i rises and exceeds the breakdown voltage V_{BRDSS} . As **V Switch** stays almost constant during avalanche and the rise- and fall-time is negligible relative to the length of the pulse, **V Switch** can be described as a simple voltage pulse. Therefore, the circuitry during the avalanche can be approximated as shown in Figure 19.

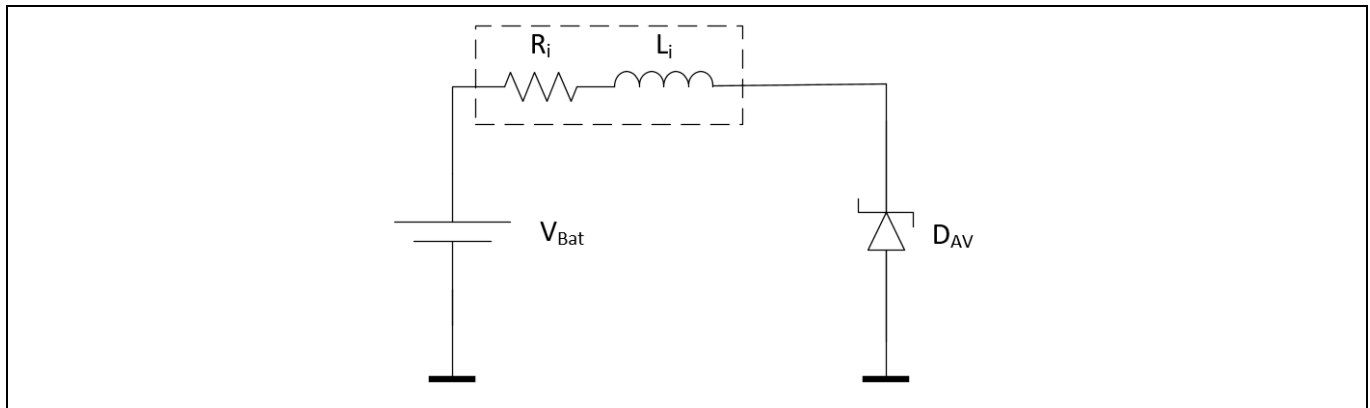

Figure 19 Approximated circuitry during avalanche breakdown

The clamping voltage of D_{AV} is the avalanche breakdown voltage (V_{AV}) of the switching MOSFETs. V_{AV} can be assumed as $1.3 \times V_{BRDSS}$. However, for all the latest OptiMOS™ families V_{DS} spikes during avalanche will not exceed $1.2 \times V_{BRDSS}$ [1]. As the diode clamps the voltage to V_{AV} during avalanche we can, in first approximation, replace the diode with a constant voltage source and get a linear differential system. By solving the differential equation, we get the current as a function of time.

$$i(t) = e^{-\frac{t}{\tau_{Bat}}} \left(I_0 - \frac{V_{Bat} - V_{AV}}{R_i} \right) + \frac{V_{Bat} - V_{AV}}{R_i}$$

Equation 2

To obtain the avalanche breakdown losses we subtract the energy losses of the resistor from the total stored energy (Equation 3).

$$E_{AV} = E_{Total} - E_R = L_i \cdot I_0^2 \cdot \left(\frac{1}{2} \cdot \frac{V_{AV}}{V_{AV} - V_{Bat}} - \frac{1}{3} \cdot \ln \left(1 - \frac{R_i \cdot I_0}{V_{Bat} - V_{AV}} \right) \right)$$

Equation 3

Note: The given equations above are only a rough approximation and should only be used for a first estimation.

4.3.1 Example calculation for the Battery Switch 12V System Demonstrator

As example calculation the initial avalanche current $I_0 = 900\text{ A}$, the internal battery resistance $R_i = 5\text{ m}\Omega$ and the internal inductance $L_i = 100\text{ nH}$ can be used. V_{AV} is approximately $1.2 \cdot V_{BRDSS}$, where $V_{BRDSS} = 40\text{ V}$ for the IPLU300N04S4-R8. By using Equation 3 we can estimate the avalanche energy.

$$E_{AV} = E_{Total} - E_R = 100\text{nH} \cdot (900\text{A})^2 \cdot \left(\frac{1}{2} \cdot \frac{48\text{V}}{48\text{V} - 12\text{V}} - \frac{1}{3} \cdot \ln \left(1 - \frac{5\text{m}\Omega \cdot 900\text{A}}{12\text{V} - 48\text{V}} \right) \right) = 50,8\text{mJ}$$

Equation 4

When assumed that the complete avalanche energy is absorbed by all six MOSFETs equally, the maximum avalanche energy can be extrapolated from the avalanche energy graph of the datasheet [2] and multiplied by six, for six parallelized MOSFETs.

Note: Due to the production distribution of V_{BRDSS} and temperature differences of the MOSFET dies the avalanche energy may not be spread equally among all MOSFETs.

4.3.2 Simulated Safe Operating Areas at different Battery Configurations

Equation 3 shows that the avalanche energy is a function of the internal resistance, inductance of the battery, the battery voltage, the avalanche breakdownvoltage of the MOSFETs and the current going through the 12 V Battery Switch Demonstrator. As these parameters are different in every application, it is not possible to estimate a single absolute maximum rating. Different battery configurations need to be considered. Additionally, the limits for the maximum avalanche energy are strongly dependent on the junction temperature of the MOSFETs. Therefore, multiple safe operating area plots based on simulation results are provided below. The simulations are done for lab conditions, at 25°C junction temperature.

Note: The results below are restricted to lab conditions. It is recommended to stay inside the SOA of the MOSFET [2]. For additional information or help with your specific application, please get in contact with Infineon Technologies AG.

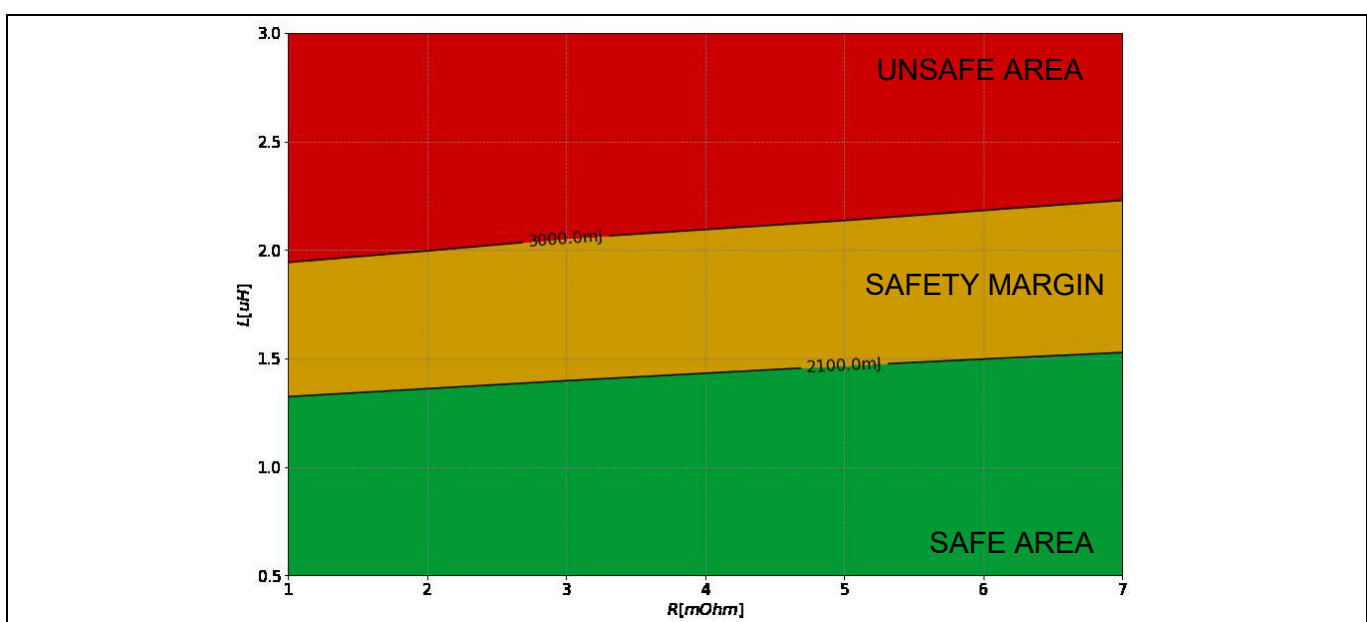

Figure 20 SOA for 12 V, Current = 1500 A, Limit = 6*500mJ, $T_j = 25^\circ\text{C}$, limit extracted from Datasheet [2]

Switching Behaviour

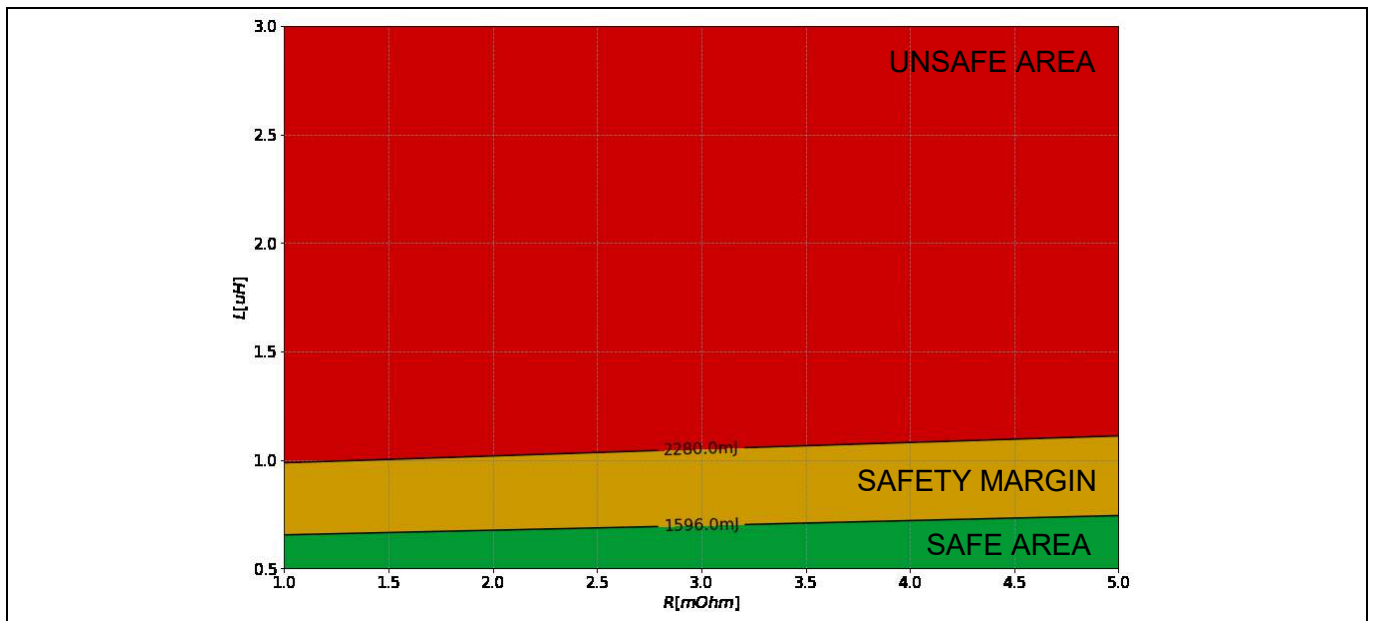

Figure 21 SOA for 12 V, Current = 1800 A, Limit = 6*380mJ, Tj=25°C, limit extracted from Datasheet [2]

5 Mechanical Dimensions

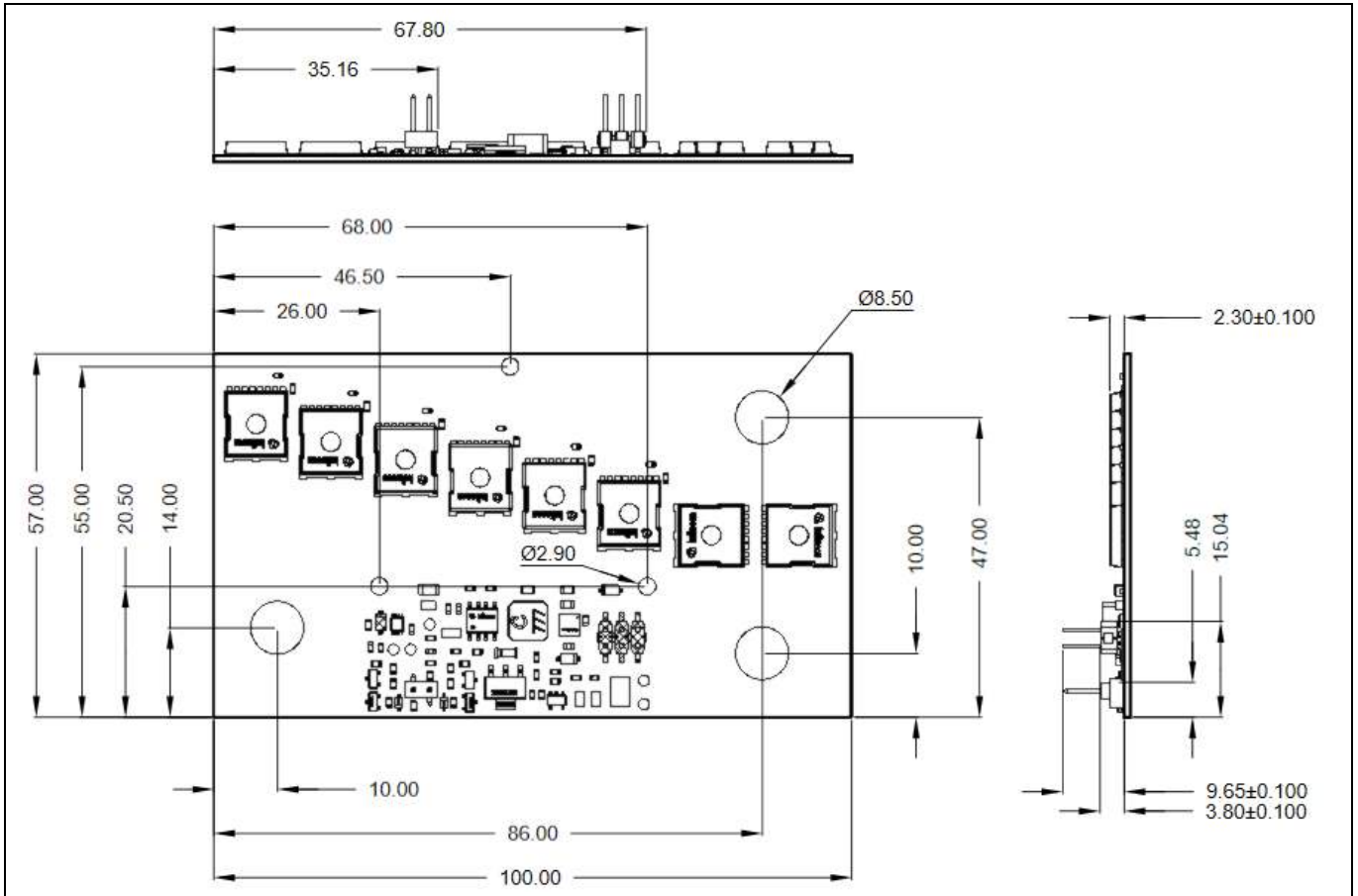

Figure 22 Board Dimensions [mm]

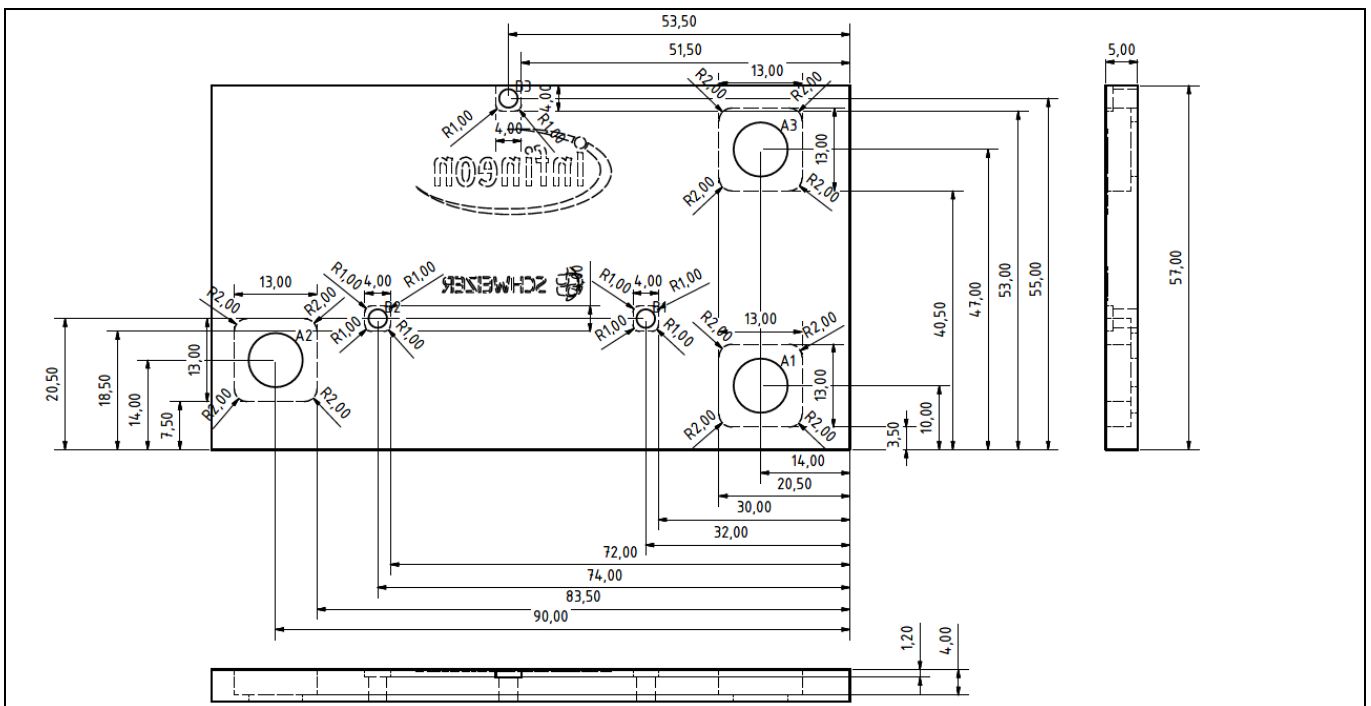

Figure 23 PCB Holder [mm]

6 Schematics

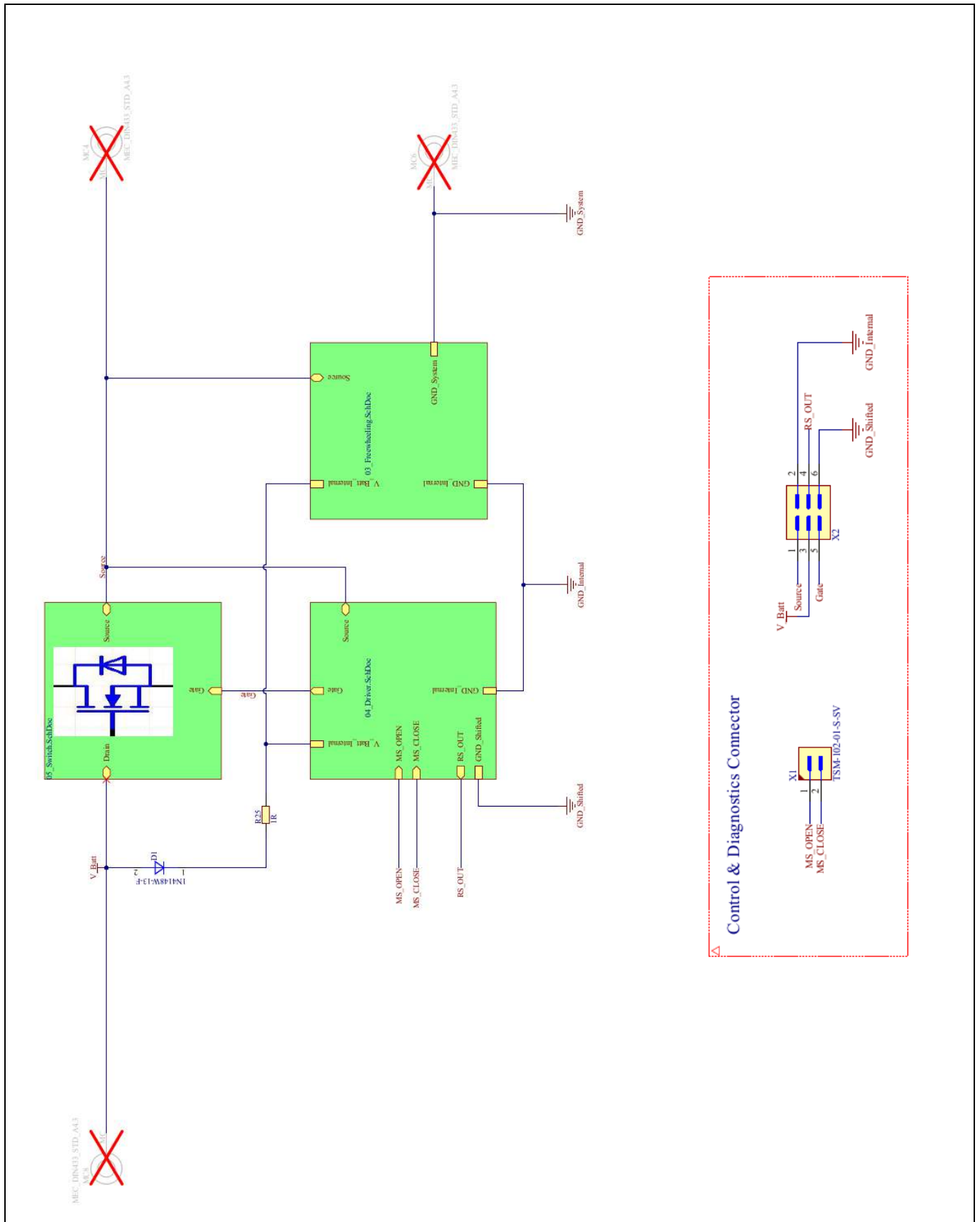

Figure 24 Top Level Schematics

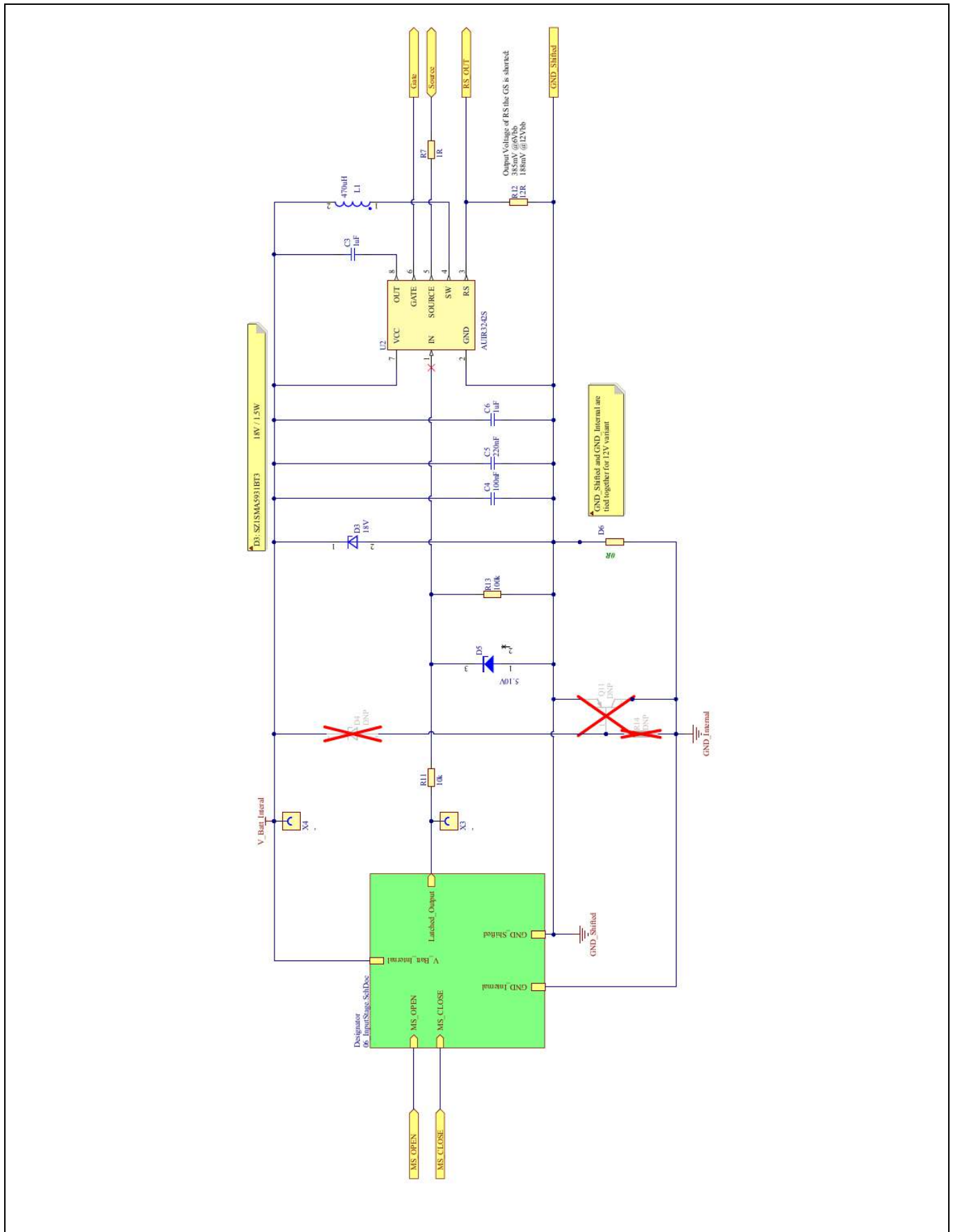

Figure 25 MOSFET Driver Circuit

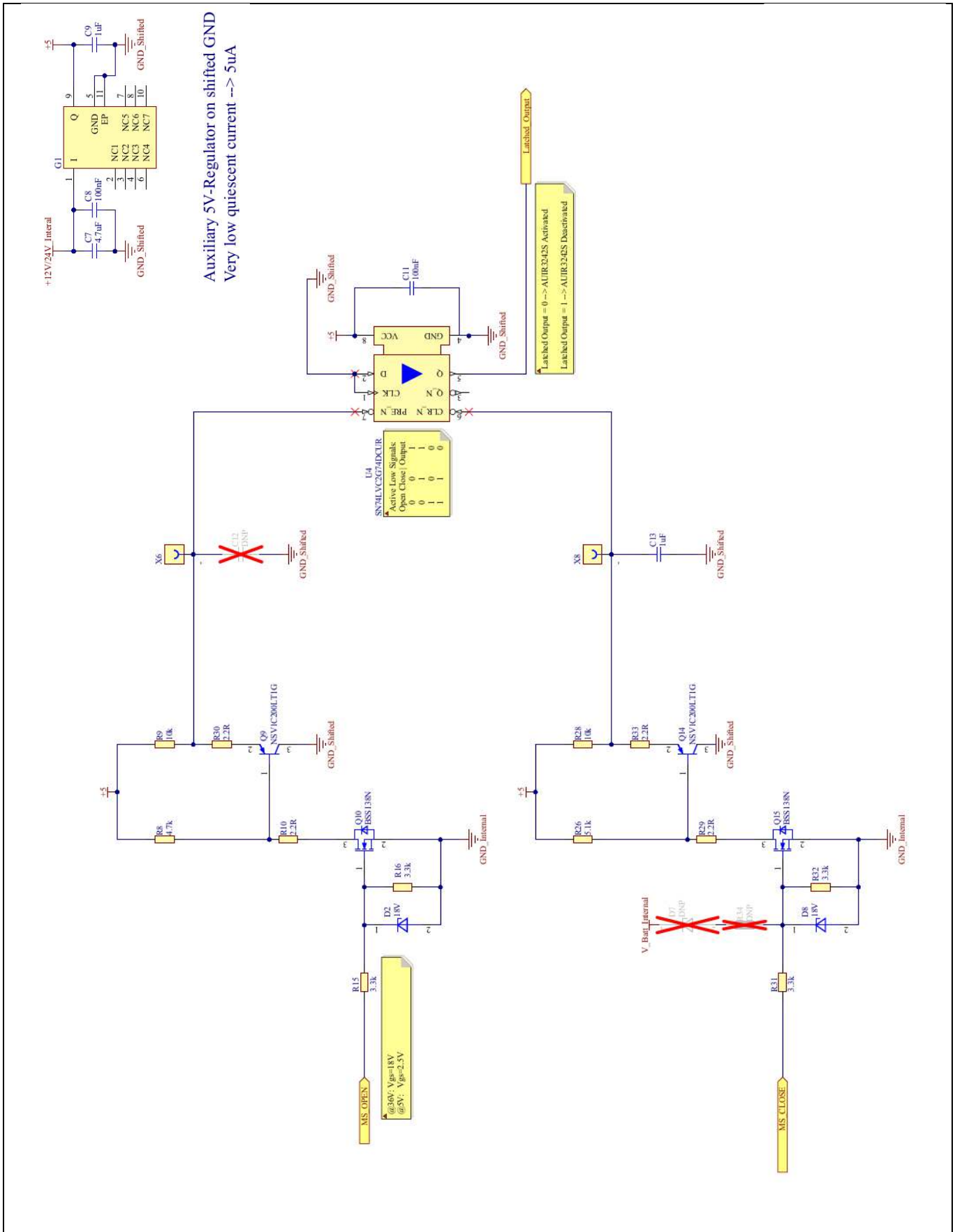

Figure 26 Input Circuitry

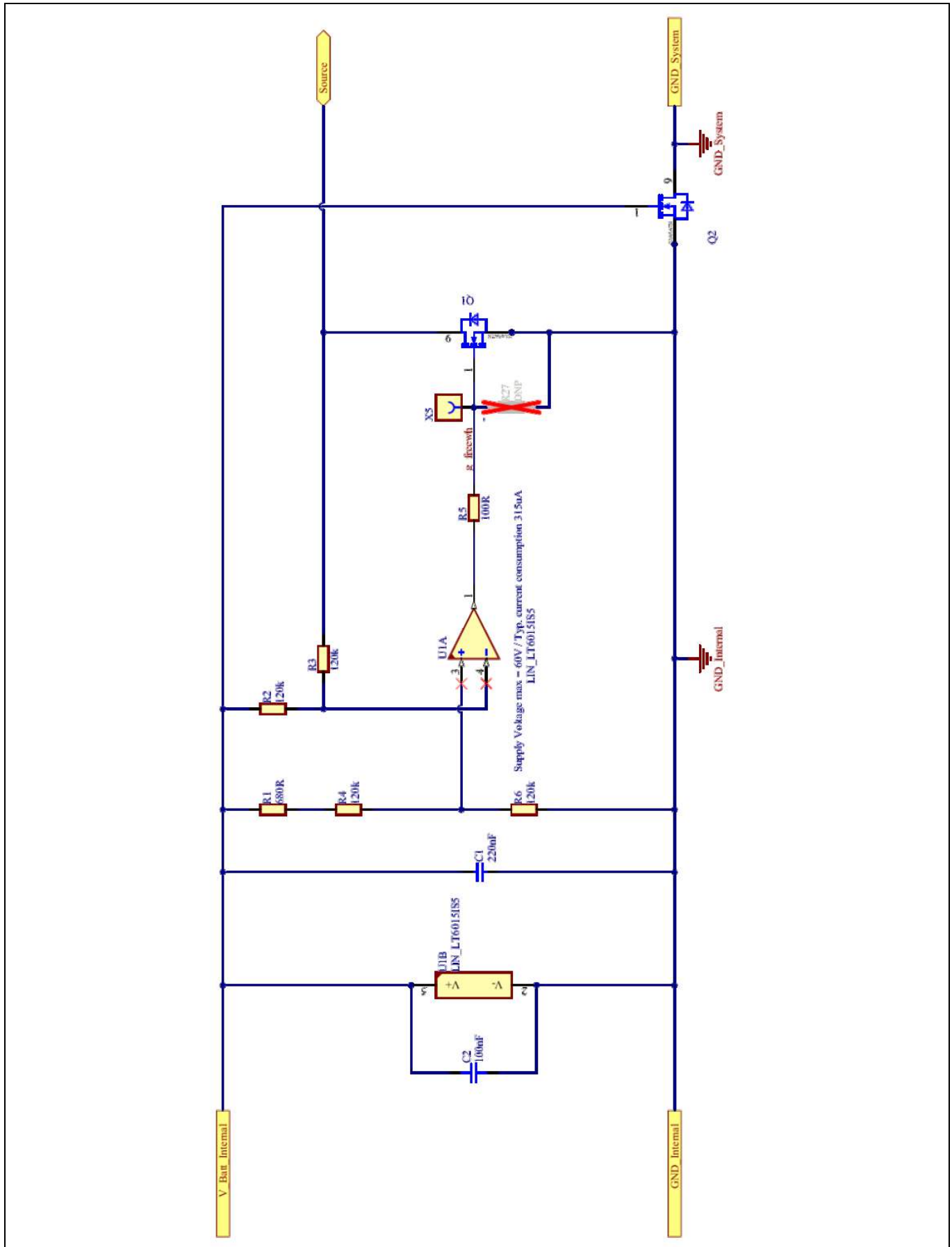

Figure 27 Active Freewheeling Circuitry

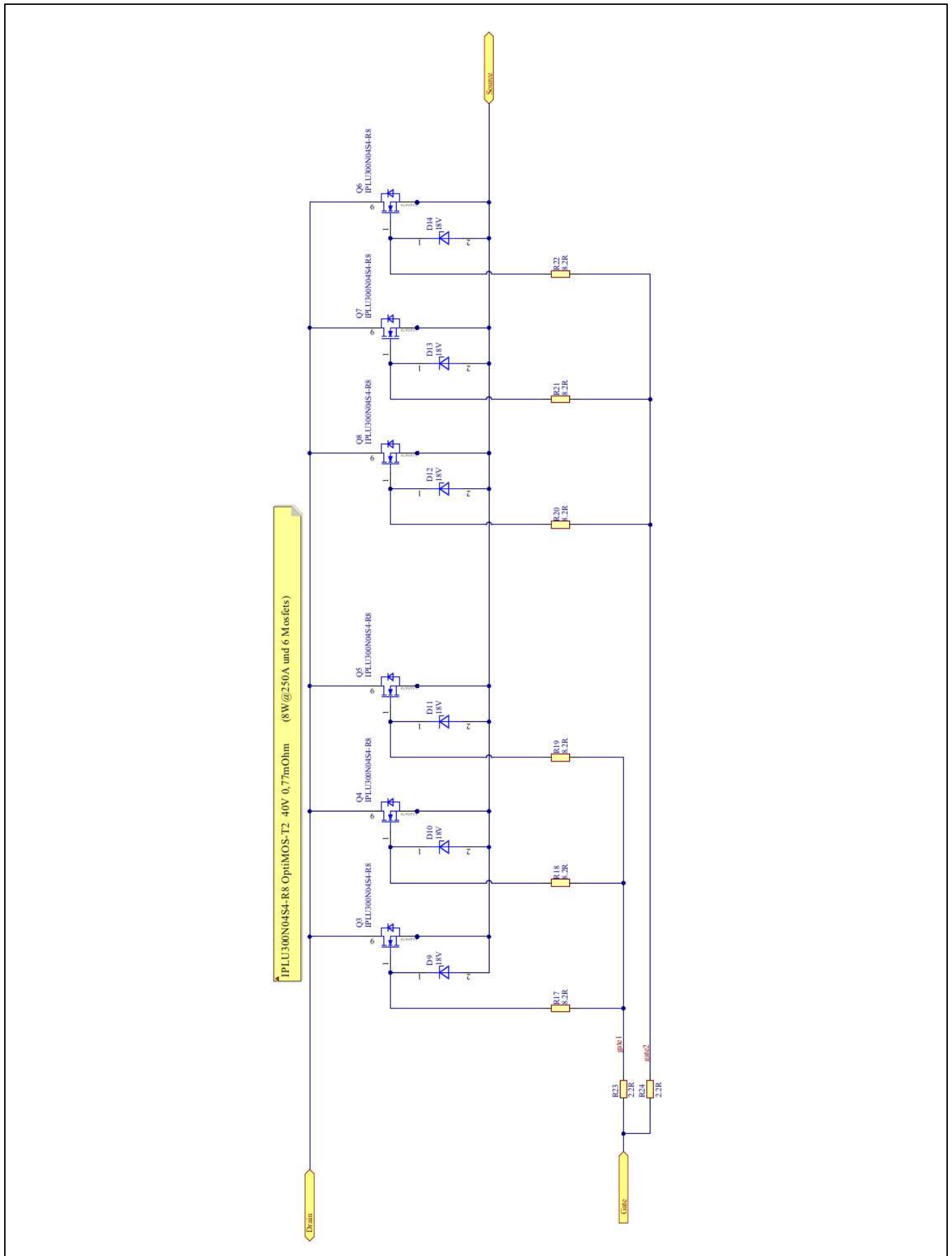

Figure 28 Power Stage

7 PCB Description

7.1 PCB Technology

The Printed Circuit Board used for the shown Battery Switch 12V System Demonstrator is a product idea of [Schweizer Electronic AG](#). The deployment of the [Inlay Board 2.0](#) technology assures highest current carrying capability in conjunction with lowest thermal resistance. A superior thermal connection between the MOSFETs and the integrated power rail of the PCB allows to conduct a permanent current of up to 300A and a short-circuit current of up to 1800A. The complete feature set is visible in Table 7.

Table 7 Feature Set of Metal Core Board (Non-Isolated Version)

Feature	Value
Size	100.0 mm x 57.0 mm
Thickness	1.3 mm
Electrical resistance	60 $\mu\Omega$
Thermal resistance (non-isolated version)	0.1 K/W
Thermal resistance (isolated version)	~ 0.2 K/W
No. of copper-filled laser vias per MOSFET	300

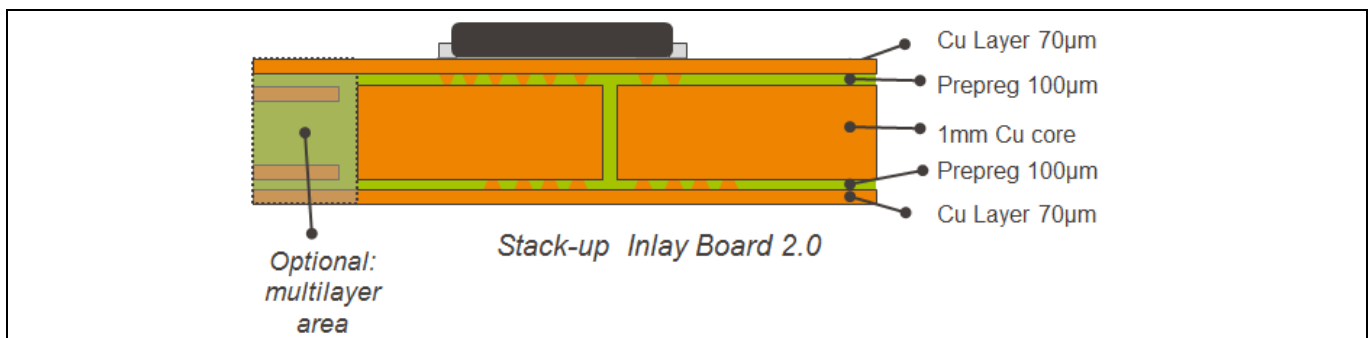

Figure 29 PCB Stackup

The PCB Stackup is shown in Figure 29. The core of the PCB is a copper plate of 1.0 mm thickness which represents the power rail for the 12 V Battery Switch Demonstrator. This copper plate is structured by an isolation gap of 500 μm width. By means of a lamination process the isolation gap is filled with the resin from Prepreg material. This represents a safe isolation space between battery and load potential. The outer layers are consisting of 35 μm copper foils, after plating 70 μm . To ensure both a low-ohmic electrical connection from the MOSFETs to the current rail and a good heat flow to a potentially used heatsink, the PCB is provided with hundreds of [copper-filled microvias](#) in the soldering area of the MOSFET and on the back-side of the PCB. The high filling factor with dimple depths lower than 25 μm allows the designer to have the MOSFETs soldered on top of the via field without facing the risk of solder voids. During assembly it has to be made sure that solder profiles will be used which are appropriate for power PCBs with a large thermal mass. The MOSFETs are placed on the PCB so that the MOSFETs, once they are turned on, connect the two isolated parts of the PCB, see cross section in Figure 30.

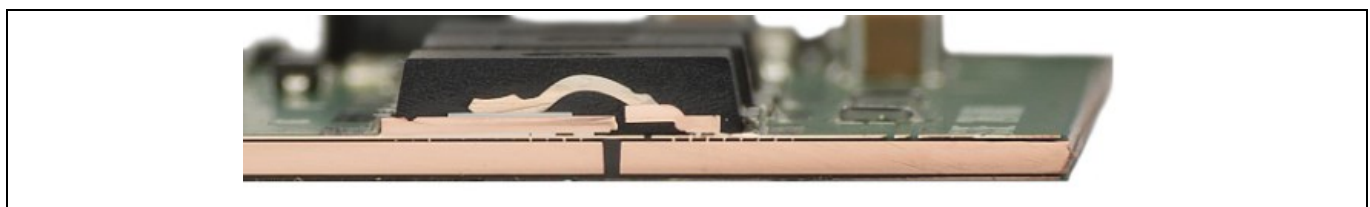

Figure 30 Cross Section

For higher logic content requirements, the Inlay Board 2.0 technology can optionally accommodate an area with four or more electrical layers next to the power rails as demonstrated with the 12 V Battery Switch Demonstrator.

7.2 PCB Layout

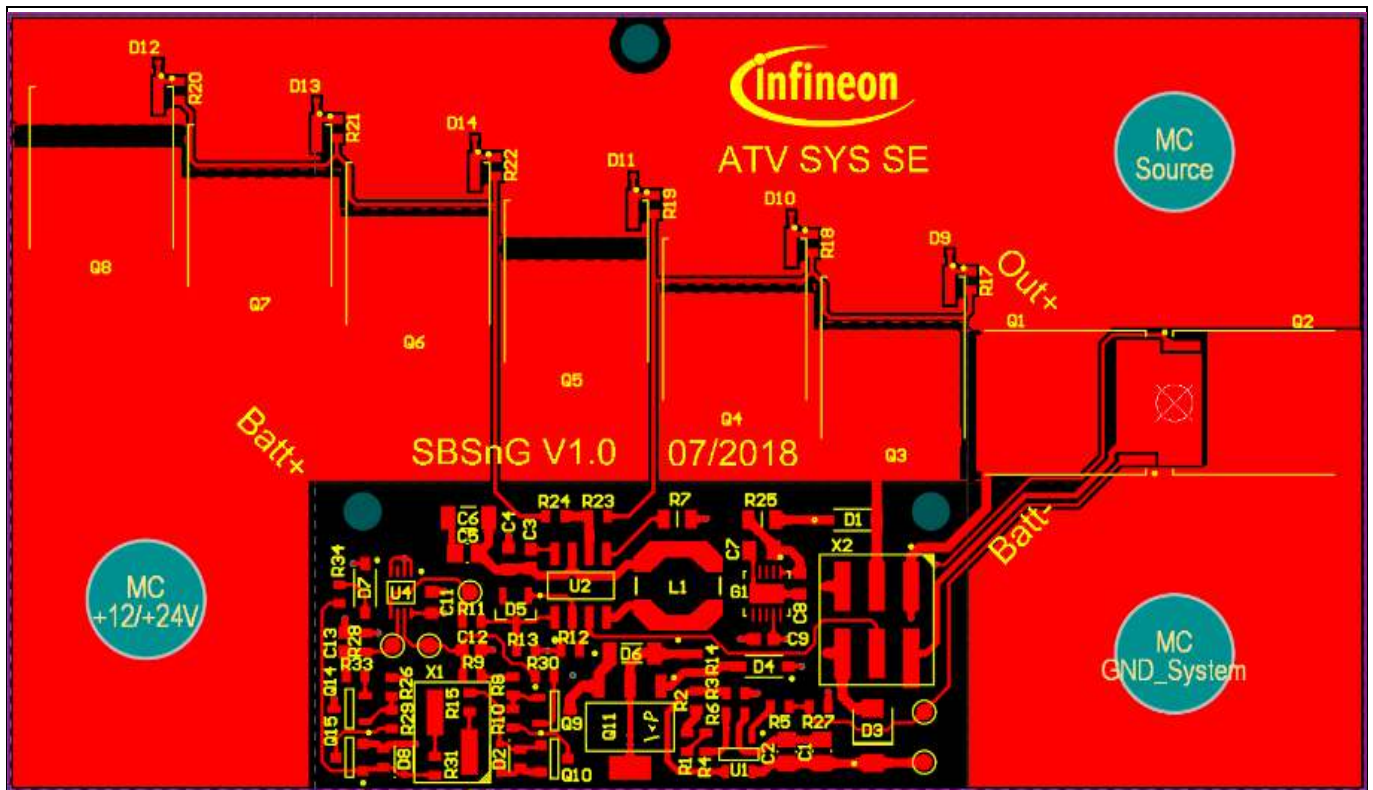

Figure 31 Top Layer

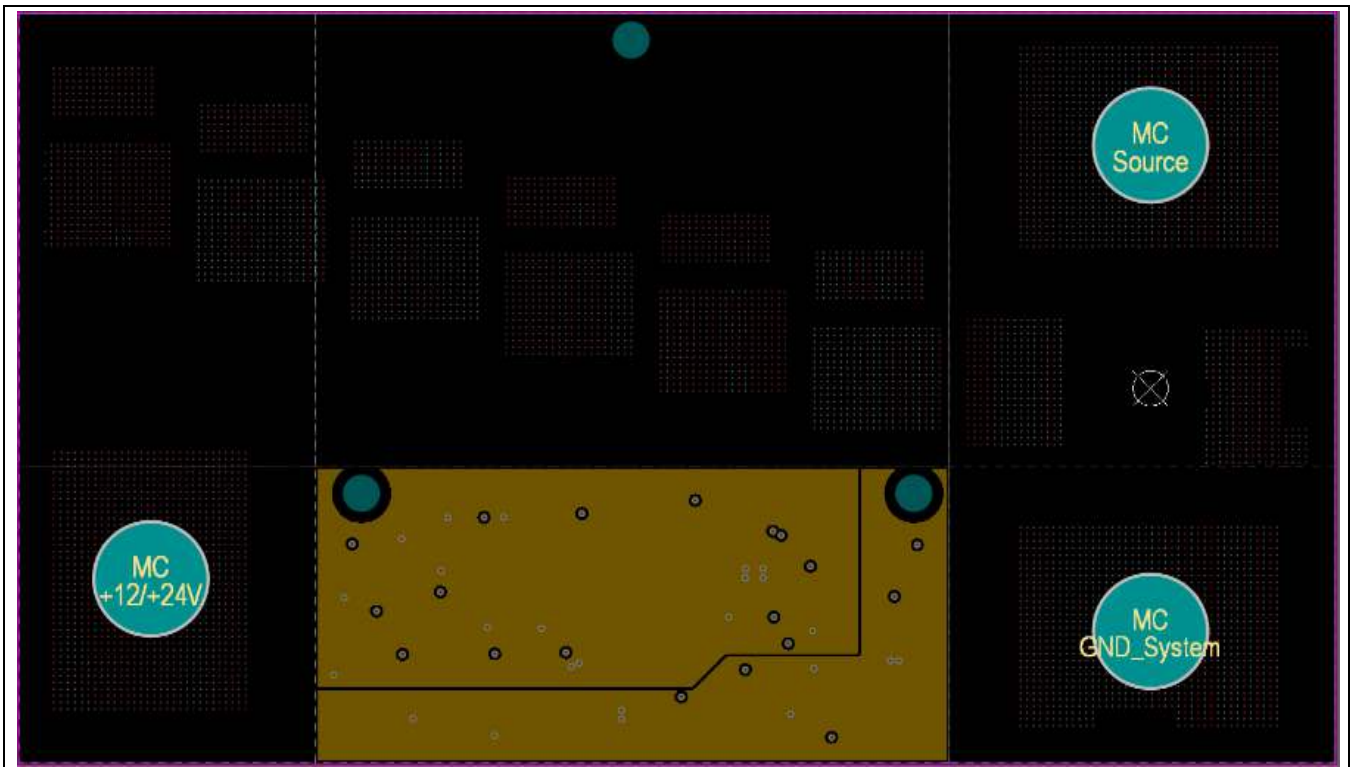

Figure 32 Logic Ground Layer

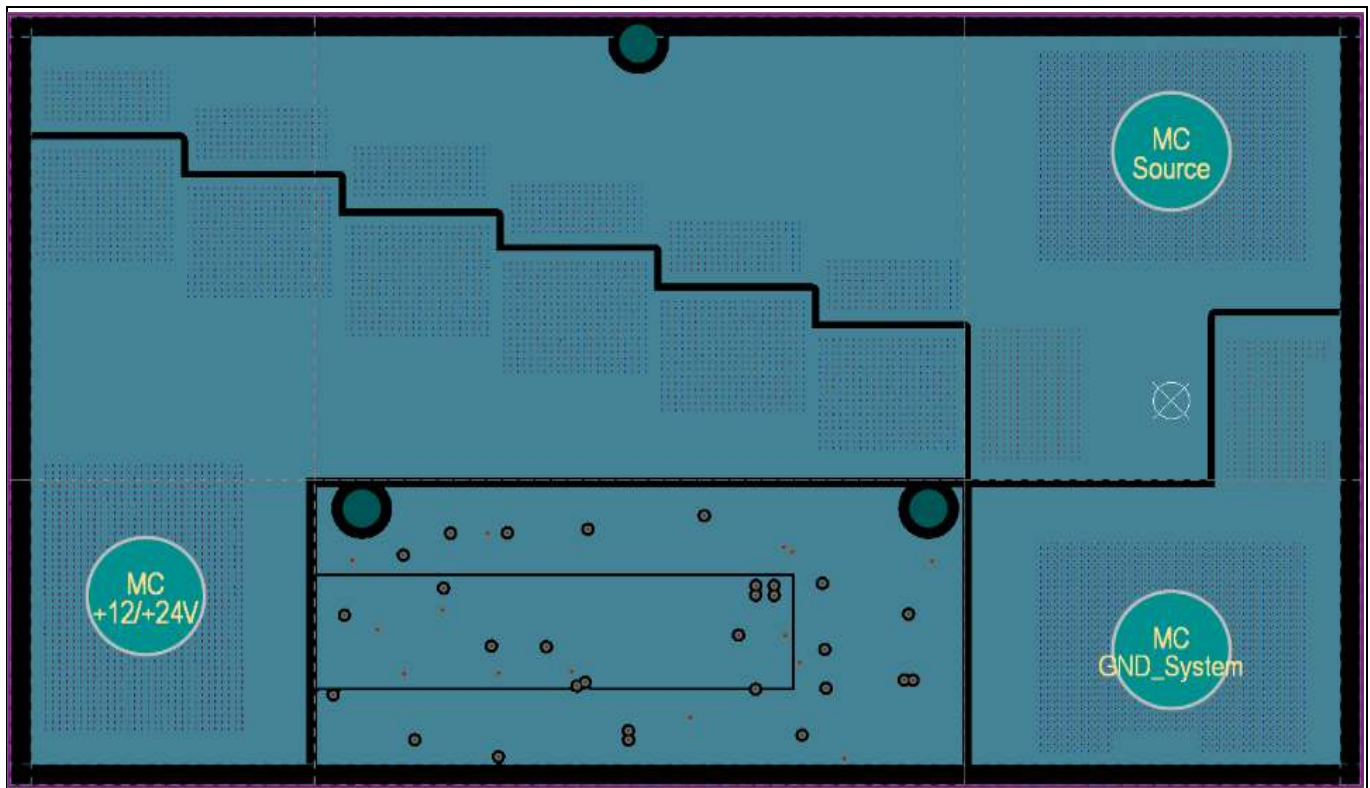

Figure 33 Power Layer

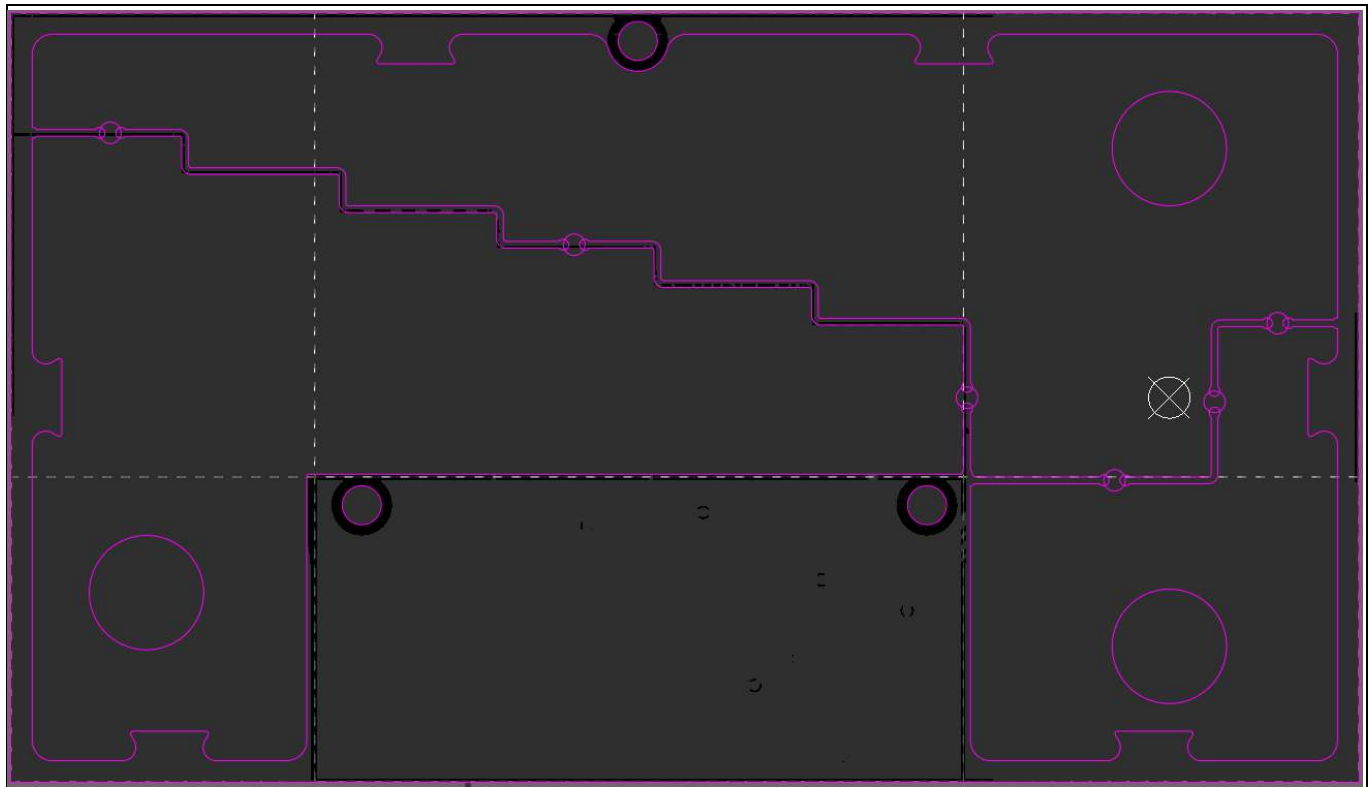

Figure 34 1mm Inlay-Design from Schweizer Electronic AG

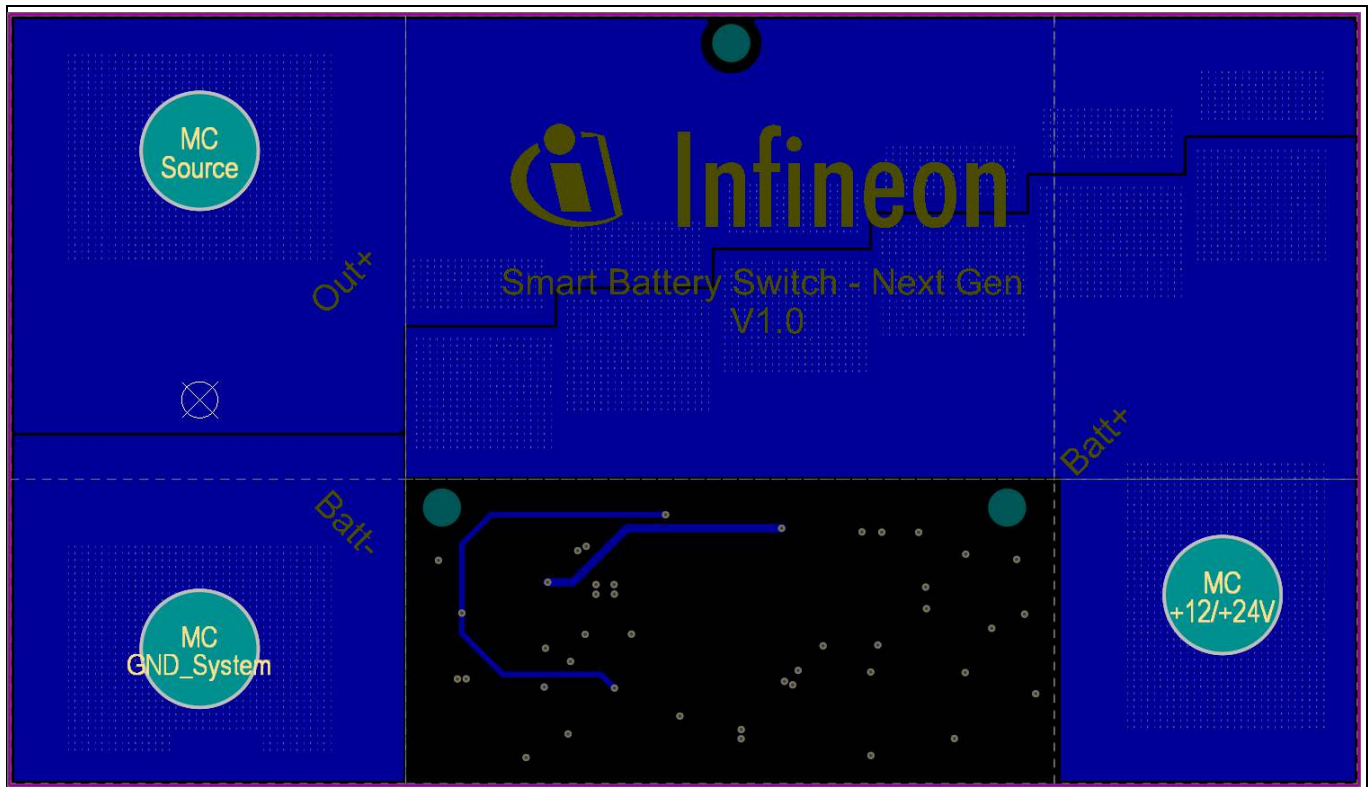

Figure 35 Bottom Layer

8 Bill Of Materials

Table 8 12V Variant

Designator	Value	Description
C1, C5	220nF/50V	Capacitor 0805 X7R 10%
C2	100nF/100V	Capacitor 0805 X7R 10%
C3, C9, C13	1uF/25V	Capacitor 0603 X7R 10%
C4, C8, C11	100nF/50V	Capacitor 0603 X7R 10%
C6	1uF/50V	Capacitor 1206 X7R 10%
C7	4.7uF/35V	Capacitor 0805 X7S 10%
D1	1N4148W-13-F	Standard Diode
D2, D8	GDZ18B-G3-08	Zener Diode, 18V, 200mW
D3	SZ1SMA5931BT3	Zener Diode, 18V, 1.5W
D5	BZX84C5V1LT1G	Zener Diode, 5.1V, 250mW
D9, D10, D11, D12, D13, D14	MM5Z18VT1G	Zener Diode, 18V, 200mW
G1	TLS810A1LD V50	Ultra Low Quiescent Linear Voltage Regulator, 5V
L1	LPS6235-474MR	Shielded Power Inductor, 470uH
Q1, Q2, Q3, Q4, Q5, Q6, Q7, Q8	IPLU300N04S4-R8	OptiMOS T2 N-Channel Enhancement Power-Transistor, 40 V
Q9, Q14	NSV1C200LT1G	100V, 2.0 A, Low VCEsat PNP Transistor
Q10, Q15	BSS138N	N-Channel Small Signal Transistor
R1	680R	Resistor 0603 75V 1%
R2, R3, R4, R6	120k	Resistor 0603 75V 1%
R5	100R	Resistor 0603 75V 1%
R7, R25	1R	Resistor 0805 150V 1%
R8	4.7k	Resistor 0603 75V 1%
R9, R11, R28	10k	Resistor 0603 75V 1%
R10, R23, R24, R29, R30, R33	2.2R	Resistor 0603 75V 1%
R12	12R	Resistor 0603 75V 1%
R13	100k	Resistor 0603 75V 1%
R15, R16, R31, R32	3.3k	Resistor 0603 75V 1%
R17, R18, R19, R20, R21, R22	8.2R	Resistor 0603 75V 1%
R26	5.1k	Resistor 0603 75V 1%
R35/D6	0R/Jumper	Resistor 1206
U1	LT6015IS5	Low Power Op Amp
U2	AUIR3242S	Low Quiescent Current Back to Back MOSFET Driver
U4	74LVC2G74	Positive Edge Triggered D-Type Flip Flop
X1	TSM-102-01-S-SV	SMT .025" SQ Post Header, 2.54mm Pitch, 2 Pin, Vertical, Single Row
X2	TSM-103-01-L-DV	SMT .025" SQ Post Header, 2.54mm Pitch, 6 Pins, Vertical, Double Row

9 References

- [1] **Some key facts about avalanche** - Infineon Technologies AG, Version 1.0, 2017-01-9
- [2] **IPLU300N04S4-R8 datasheet** - Infineon Technologies AG, Rev. 1.0, 2015-10-06
- [3] **AUIR3242S datasheet** - Infineon Technologies AG, Rev. 1.0, 2018-07-26

Revision History

Major changes since revision 1.1

Page or Reference	Description of change
	Updated filename and demonstrator nomenclature

Major changes since revision 1.0

Page or Reference	Description of change
Page 4	Added some more details to Figure 3
Page 6	Clarify descriptions of connector X1 and X2
Page 15	Added Figure 18 to explain the switching event in more detail

Trademarks of Infineon Technologies AG

μ HVIC™, μ IPM™, μ PFC™, AU-ConvertIR™, AURIX™, C166™, CanPAK™, CIPOS™, CIPURSE™, CoolDP™, CoolGaN™, COOLiR™, CoolMOS™, CoolSET™, CoolSiC™, DAVE™, DI-POL™, DirectFET™, DrBlade™, EasyPIM™, EconoBRIDGE™, EconoDUAL™, EconoPACK™, EconoPIM™, EiceDRIVER™, eupec™, FCOS™, GaNpowIR™, HEXFET™, HITFET™, HybridPACK™, iMOTION™, IRAM™, ISOFACE™, IsoPACK™, LEDrivIR™, LITIX™, MIPAQ™, ModSTACK™, my-d™, NovalithIC™, OPTIGA™, OptiMOS™, ORIGA™, PowIRaudio™, PowIRStage™, PrimePACK™, PrimeSTACK™, PROFET™, PRO-SIL™, RASIC™, REAL3™, SmartLEWIS™, SOLID FLASH™, SPOC™, StrongIRFET™, SupIRBuck™, TEMPFET™, TRENCHSTOP™, TriCore™, UHVIC™, XHP™, XMC™

Trademarks updated November 2015

Other Trademarks

All referenced product or service names and trademarks are the property of their respective owners.

Edition 2020-09-09

Published by

Infineon Technologies AG

81726 Munich, Germany

© 2020 Infineon Technologies AG.

All Rights Reserved.

IMPORTANT NOTICE

The information contained in this application note is given as a hint for the implementation of the product only and shall in no event be regarded as a description or warranty of a certain functionality, condition or quality of the product. Before implementation of the product, the recipient of this application note must verify any function and other technical information given herein in the real application. Infineon Technologies hereby disclaims any and all warranties and liabilities of any kind (including without limitation warranties of non-infringement of intellectual property rights of any third party) with respect to any and all information given in this application note.

The data contained in this document is exclusively intended for technically trained staff. It is the responsibility of customer's technical departments to evaluate the suitability of the product for the intended application and the completeness of the product information given in this document with respect to such application.

For further information on the product, technology delivery terms and conditions and prices please contact your nearest Infineon Technologies office (www.infineon.com).

WARNINGS

Due to technical requirements products may contain dangerous substances. For information on the types in question please contact your nearest Infineon Technologies office.

Except as otherwise explicitly approved by Infineon Technologies in a written document signed by authorized representatives of Infineon Technologies, Infineon Technologies' products may not be used in any applications where a failure of the product or any consequences of the use thereof can reasonably be expected to result in personal injury.