

PART NAME: KNOB SCALE: 1:1 DATE: 11/1/16 DR. BY JAM

THIS DRAWING IS THE PROPERTY OF DAVIES MOLDING COMPANY, IS SUBMITTED SOLELY AS A DESIGN OR ENGINEERING PROJECT. WE ACCEPT NO RESPONSIBILITY WHATSOEVER FOR THE PRACTICAL APPLICATION OF THE PIECES MADE TO THIS DESIGN.

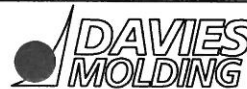

DESIGNERS & MANUFACTURERS OF KNOBS, HANDLES, CASES & CUSTOM PLASTIC COMPONENTS

P/N 0033AG-AJ

	THREAD	A	B	C	D	COLOR
0033AG	M6 X 1	35	34	16	12	BLACK
0033AH	M8 X 1.25	35	34	16	12	BLACK
0033AJ	M10 X 1.5	35	34	16	15	BLACK
0033AN	M10 X 1.5	35	34	16	15	RED
0033AK	M12 X 1.75	35	34	16	18	BLACK

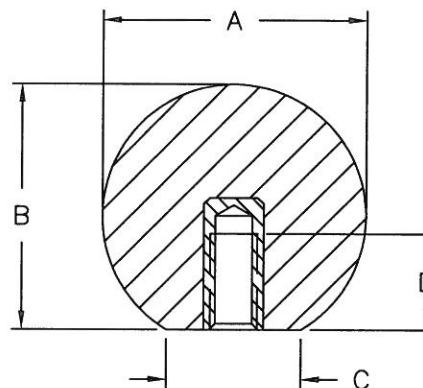

THREADED INTERNAL INSERT

KNOB MATERIAL: PHENOLIC
COLOR: BLACK

INSERT MATERIAL: INTERNAL INSERTS ARE BRASS,
PROJECTING STUDS ARE ZINC PLATED STEEL

TOLERANCES: UNLESS OTHERWISE SPECIFIED	DO NOT SCALE DRAWING				
	MM: X.XX ± 0.15MM X.X ± 0.4MM				
	ANG. ± 1'	CHANGES			