

Customer Information Sheet

DRAWING No.: M55-820XX42

IF IN DOUBT - ASK

©

NOT TO SCALE

THIRD ANGLE PROJECTION

ALL DIMENSIONS IN mm

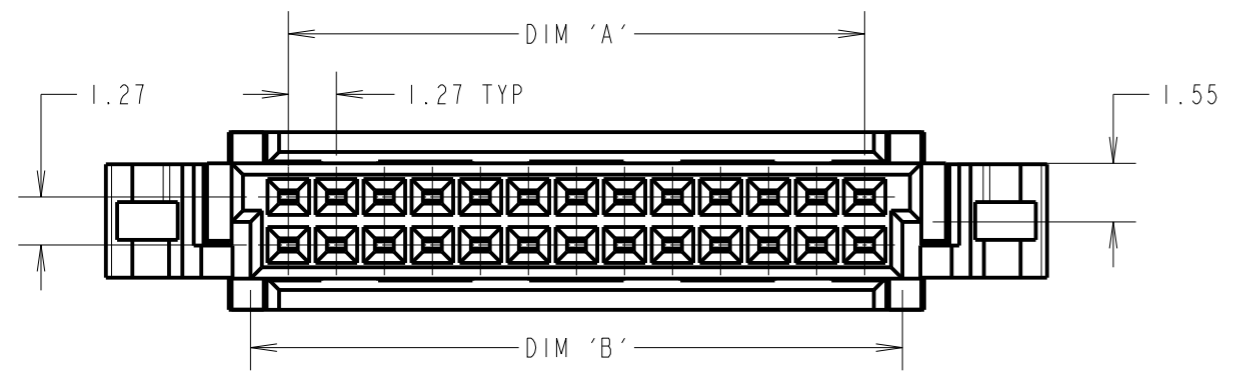

PART NUMBER	No. OF CONTACTS	DIM 'A'	DIM 'B'	DIM 'C'	DIM 'D'	DIM 'E'
M55-8201242	12	6.35	8.35	9.35	7.82	16.0
M55-8201642	16	8.89	10.89	11.89	10.36	18.5
M55-8202042	20	11.43	13.43	14.43	12.90	21.1
M55-8202642	26	15.24	17.24	18.24	16.71	24.9
M55-8203242	32	19.05	21.05	22.05	20.52	28.7
M55-8204042	40	24.13	26.13	27.13	25.60	33.8
M55-8205042	50	30.48	32.48	33.48	31.95	40.1
M55-8206842	68	41.91	43.91	44.91	43.38	51.6
M55-8208042	80	49.53	51.53	52.53	51.00	59.2

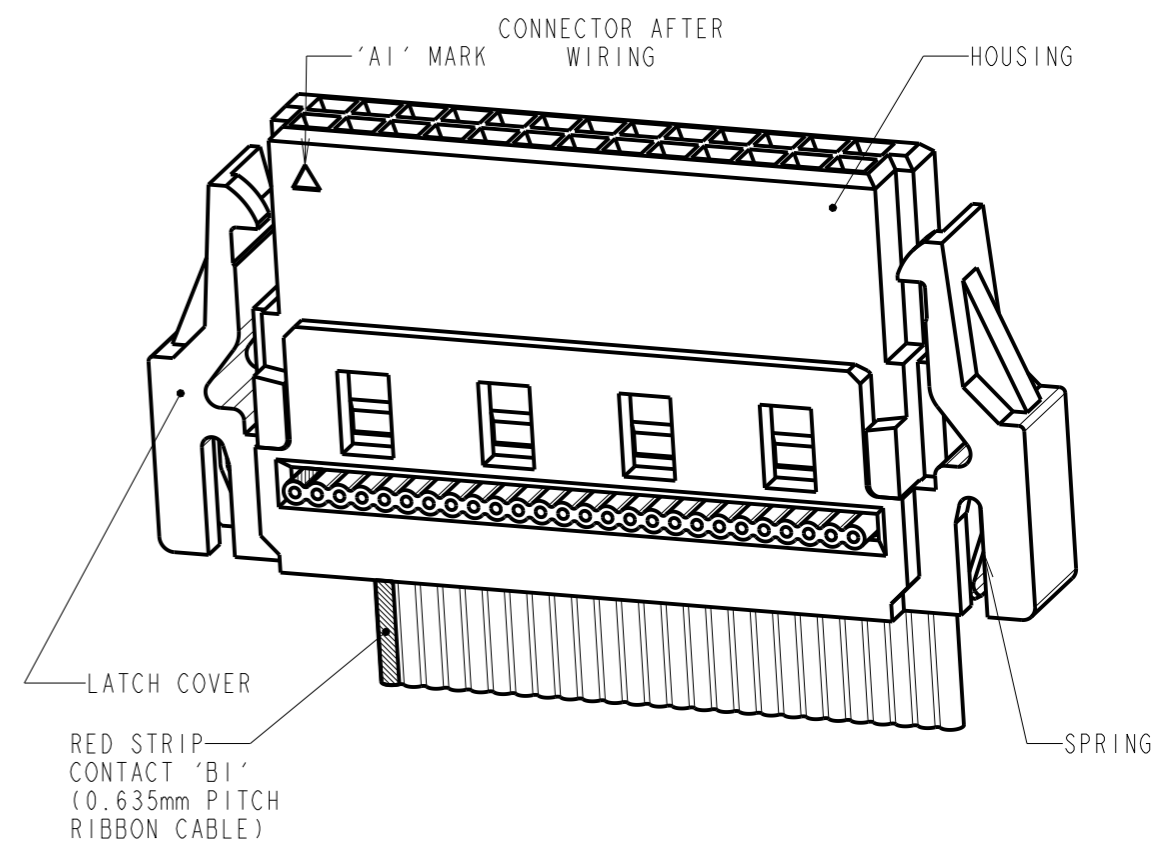
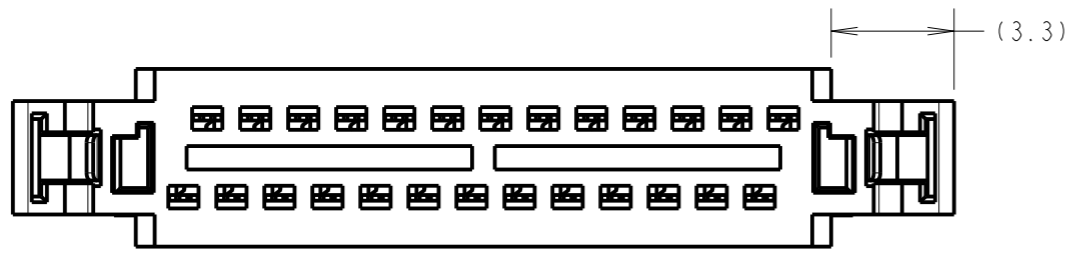
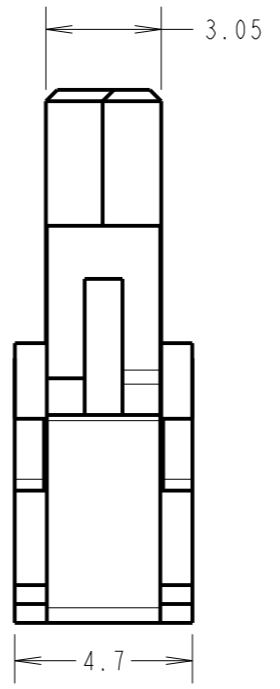
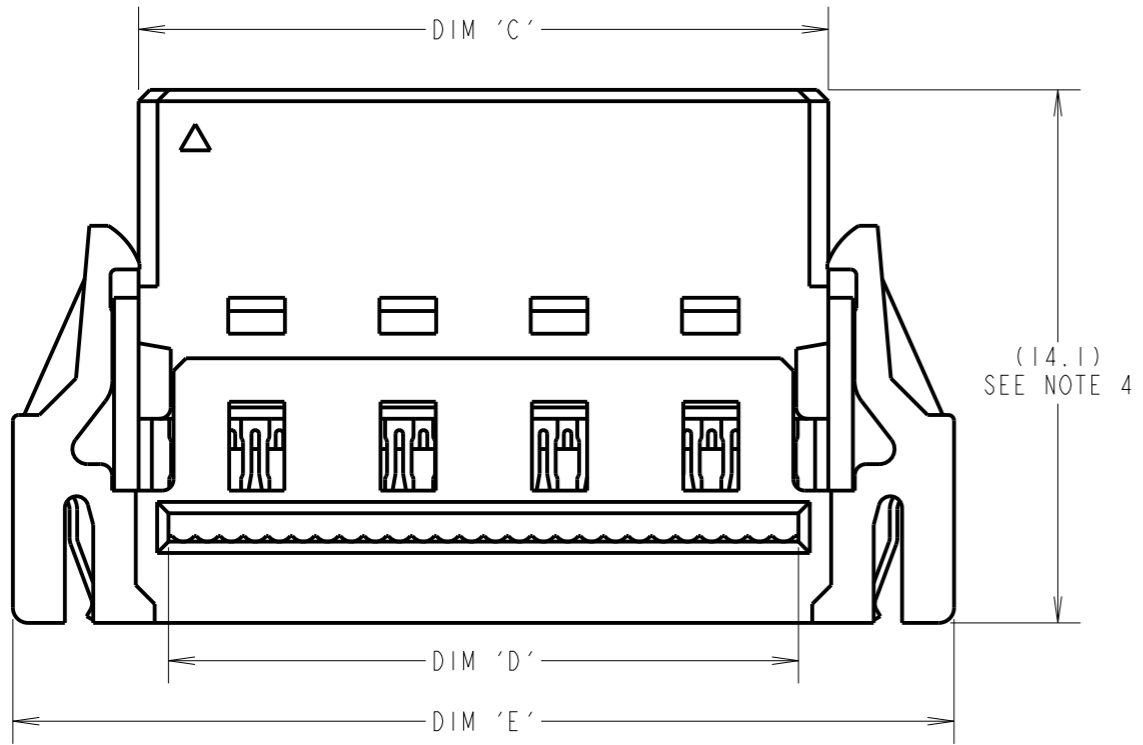

- NOTES:
- RECOMMENDED FOR USE WITH UL2678 30AWG 0.635mm PITCH IDC FLAT RIBBON CABLE.
 - FOR PREMADE CABLE ASSEMBLIES SEE PART NUMBER: M55-800XX42-XXXXA.
 - FOR COMPLETE SPECIFICATION, SEE COMPONENT SPECIFICATION C047XX (LATEST ISSUE).
 - CONNECTOR HEIGHT ONCE ASSEMBLED WITH WIRE IS 12.2mm.
 - CONNECTORS PACKAGED IN TRAYS. SEE SHEET 4 FOR DETAILS.
 - RECOMMENDED ASSEMBLY TOOL = Z55-020. SEE INSTRUCTION SHEET IS-51 FOR ASSEMBLY INSTRUCTIONS.

MGP	2	04.08.22	31771
NAME	ISS.	DATE	CN/CO
APPROVED: MGP			
CHECKED: RTP			
DRAWN: R.ALEXANDER			
CUSTOMER REF.:			
ASSEMBLY DRG: M55-800XX42-XXXXA			

ORDER CODE:
M55-820XX42

TOTAL No. OF CONTACTS: 12, 16, 20, 26, 32, 40, 50, 68, 80

FINISH: 42 = GOLD FLASH ON CONTACT AREA, TIN TAILS

HARWIN

www.harwin.com
technical@harwin.com

THIS DRAWING AND ANY INFORMATION OR DESCRIPTIVE MATTER SET OUT HEREON ARE CONFIDENTIAL AND COPYRIGHT PROPERTY OF THE HARWIN GROUP AND MUST NOT BE DISCLOSED, LOANED, COPIED OR USED FOR MANUFACTURING, TENDERING OR FOR ANY OTHER PURPOSE WITHOUT THEIR WRITTEN PERMISSION.

TOLERANCES
X. = ±1mm
X.X = ±0.50mm
X.XX = ±0.20mm
X.XXX = ±0.01mm
ANGLES = ±5°
UNLESS STATED

MATERIAL:
SEE C047XX (LATEST ISSUE)
FINISH: SEE ORDER CODE & C047XX
S/AREA: mm²

TITLE:
1.27mm PITCH IDC FEMALE CABLE CONNECTOR
DRAWING NUMBER:
M55-820XX42

Customer Information Sheet

DRAWING No.: M55-820XX42

IF IN DOUBT - ASK

©

NOT TO SCALE

THIRD ANGLE PROJECTION

ALL DIMENSIONS IN mm

CHAMFERED
CORNER IDENT

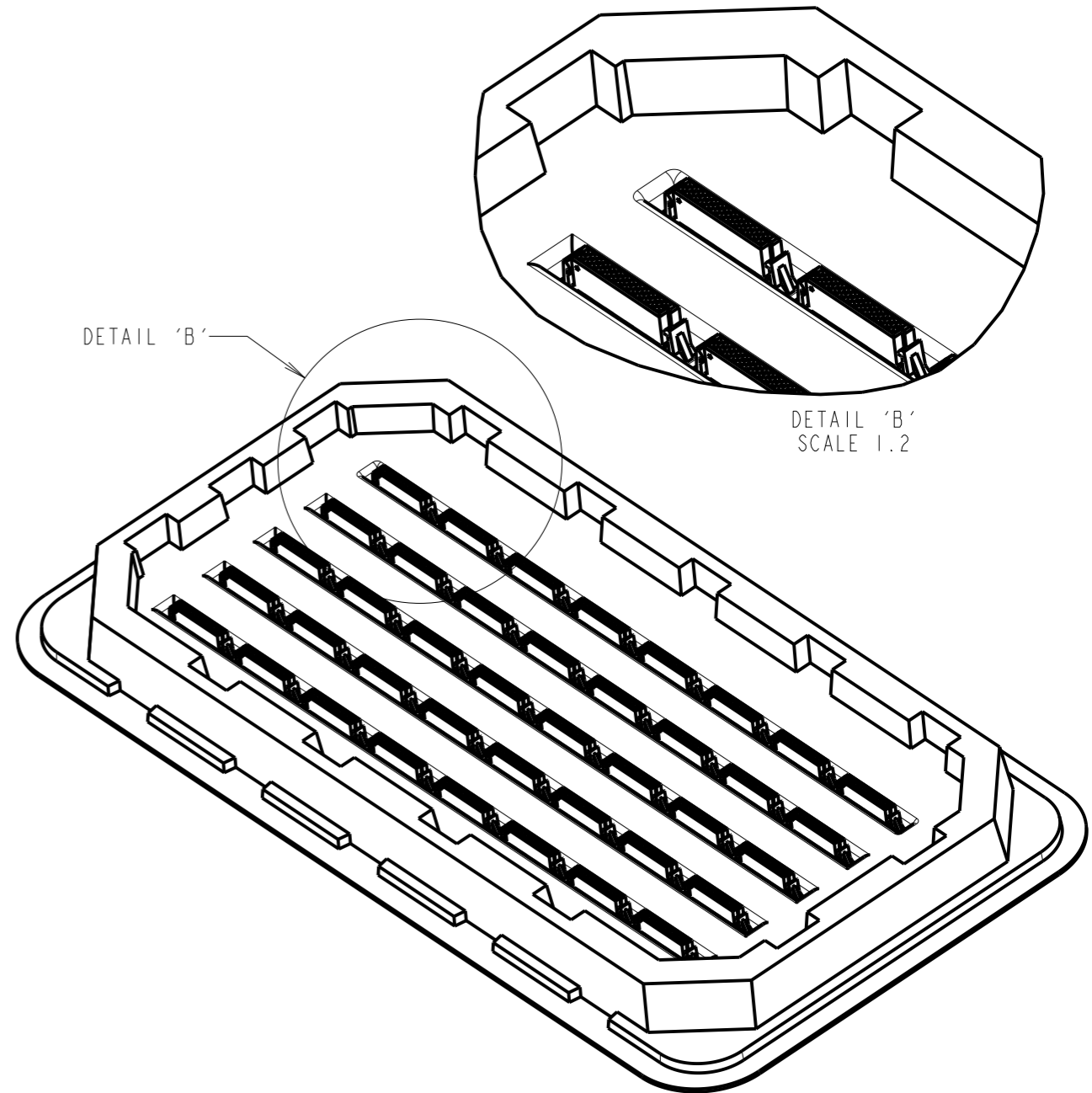
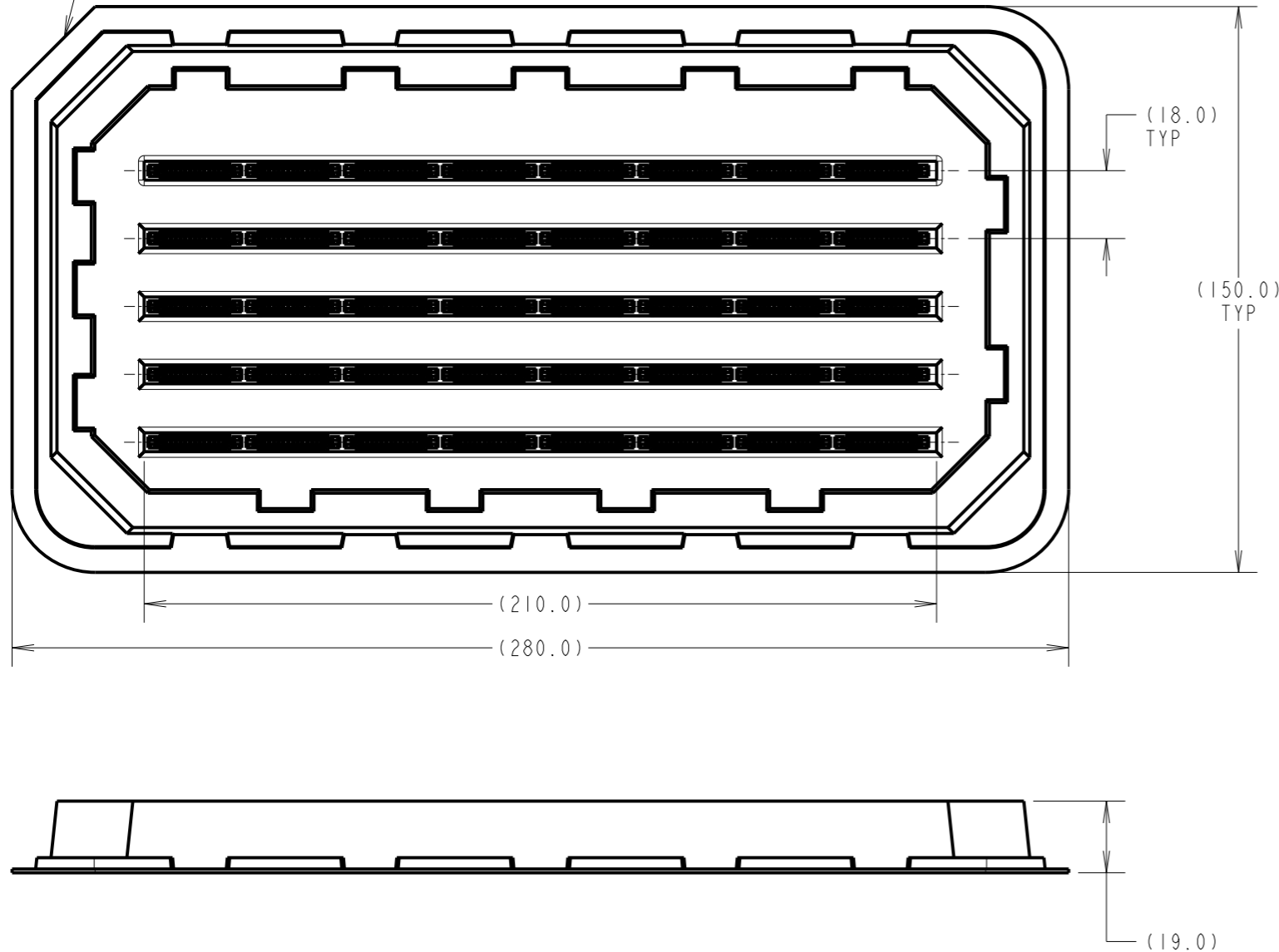

PART NUMBER	PARTS PER ROW	PARTS PER TRAY	PARTS PER BOX
M55-8201242	12	60	780
M55-8201642	11	55	715
M55-8202042	9	45	585
M55-8202642	8	40	520
M55-8203242	7	35	455
M55-8204042	6	30	390
M55-8205042	5	25	325
M55-8206842	4	20	260
M55-8208042	3	15	195

NOTES:
6. FOR COMPONENT DETAILS SEE SHEET 3.

ORDER CODE:

M55-820XX42

TOTAL No. OF CONTACTS: 12, 16, 20, 26, 32, 40, 50, 68, 80
FINISH: 42 = GOLD FLASH ON CONTACT AREA, TIN TAILS

MGP	2	04.08.22	31771
NAME	ISS.	DATE	CN/CO
APPROVED: MGP			
CHECKED: RTP			
DRAWN: R.ALEXANDER			
CUSTOMER REF.:			
ASSEMBLY DRG: M55-800XX42-XXXXA			

HARWIN

www.harwin.com
technical@harwin.com

THIS DRAWING AND ANY INFORMATION OR DESCRIPTIVE MATTER SET OUT HEREON ARE CONFIDENTIAL AND COPYRIGHT PROPERTY OF THE HARWIN GROUP AND MUST NOT BE DISCLOSED, LOANED, COPIED OR USED FOR MANUFACTURING, TENDERING OR FOR ANY OTHER PURPOSE WITHOUT THEIR WRITTEN PERMISSION.

TOLERANCES
X. = ±1mm
X.X = ±0.50mm
X.XX = ±0.20mm
X.XXX = ±0.01mm
ANGLES = ±5°
UNLESS STATED

MATERIAL:
SEE C047XX
(LATEST ISSUE)
FINISH: SEE ORDER CODE & C047XX
S/AREA: mm²

TITLE:
1.27mm PITCH IDC
FEMALE CABLE CONNECTOR

DRAWING NUMBER:
M55-820XX42

SHT
4
OF
4