



Micropower, Low Noise Precision Voltage References with Shutdown

ADR390/ADR391/ADR392/ADR395

FEATURES

Compact 5-lead TSOT packages

Low temperature coefficient

B grade: 9 ppm/°C

A grade: 25 ppm/°C

Initial accuracy

B grade: ±4 mV maximum (ADR390)

A grade: ±6 mV maximum

Ultralow output noise: 5 µV p-p (0.1 Hz to 10 Hz)

Low dropout: 300 mV

Low supply current

3 µA maximum in shutdown

120 µA maximum in operation

No external capacitor required

Output current: 5 mA

Wide temperature range: -40°C to +125°C

APPLICATIONS

Battery-powered instrumentation

Portable medical instrumentation

Data acquisition systems

Industrial process controls

Automotive

GENERAL DESCRIPTION

The ADR390/ADR391/ADR392/ADR395 are precision 2.048 V, 2.5 V, 4.096 V, and 5 V band gap voltage references, respectively, featuring low power and high precision in a tiny footprint. Using patented temperature drift curvature correction techniques from Analog Devices, Inc., the ADR39x references achieve a low 9 ppm/°C of temperature drift in the TSOT package.

PIN CONFIGURATION

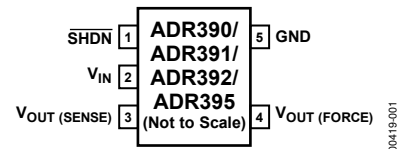

Figure 1. 5-Lead TSOT (UJ Suffix)

Table 1.

Model	Output Voltage (V _o)	Temperature Coefficient (ppm/°C)	Accuracy (mV)
ADR390B	2.048	9	±4
ADR390A	2.048	25	±6
ADR391B	2.5	9	±4
ADR391A	2.5	25	±6
ADR392B	4.096	9	±5
ADR392A	4.096	25	±6
ADR395B	5.0	9	±5
ADR395A	5.0	25	±6

The ADR39x family of micropower, low dropout voltage references provides a stable output voltage from a minimum supply of 300 mV above the output. Their advanced design eliminates the need for external capacitors, which further reduces board space and system cost. The combination of low power operation, small size, and ease of use makes the ADR39x precision voltage references ideally suited for battery-operated applications.

Rev. G

Information furnished by Analog Devices is believed to be accurate and reliable. However, no responsibility is assumed by Analog Devices for its use, nor for any infringements of patents or other rights of third parties that may result from its use. Specifications subject to change without notice. No license is granted by implication or otherwise under any patent or patent rights of Analog Devices. Trademarks and registered trademarks are the property of their respective owners.

TABLE OF CONTENTS

Features	1	ESD Caution.....	7
Applications.....	1	Terminology.....	8
Pin Configuration.....	1	Typical Performance Characteristics	9
General Description.....	1	Theory of Operation	16
Specifications.....	3	Device Power Dissipation Considerations.....	16
ADR390 Electrical Characteristics.....	3	Shutdown Mode Operation	16
ADR391 Electrical Characteristics.....	4	Applications Information	17
ADR392 Electrical Characteristics.....	5	Basic Voltage Reference Connection	17
ADR395 Electrical Characteristics.....	6	Capacitors.....	18
Absolute Maximum Ratings.....	7	Outline Dimensions	19
Thermal Resistance	7	Ordering Guide	19
REVISION HISTORY			
2/08—Rev. F to Rev. G			
Changes to Ripple Rejection Ration Parameter (Table 2).....	3	Changes to Thermal Resistance.....	7
Changes to Ripple Rejection Ration Parameter (Table 3).....	4	Moved ESD Caution.....	7
Changes to Ripple Rejection Ration Parameter (Table 4).....	5	Changes to Figure 3, Figure 4, Figure 7, and Figure 8.....	9
Changes to Ripple Rejection Ration Parameter (Table 5).....	6	Changes to Figure 11, Figure 12, Figure 13, and Figure 14.....	10
Changes to Figure 7.....	9	Changes to Figure 15, Figure 16, Figure 19, and Figure 20.....	11
Changes to Outline Dimensions.....	19	Changes to Figure 23 and Figure 24.....	12
Changes to Ordering Guide	19	Changes to Figure 27.....	13
5/05—Rev. E to Rev. F			
Changes to Table 5.....	7	Changes to Ordering Guide	19
Changes to Figure 2.....	9	Updated Outline Dimensions	19
4/04—Rev. D to Rev. E			
Changes to ADR390—Specifications.....	3	10/02—Rev. B to Rev. C	
Changes to ADR391—Specifications.....	4	Add parts ADR392 and ADR395	Universal
Changes to ADR392—Specifications.....	5	Changes to Features	1
Changes to ADR395—Specifications.....	6	Changes to General Description	1
4/04—Rev. C to Rev. D			
Updated Format.....	Universal	Additions to Table I.....	1
Changes to Title	1	Changes to Specifications.....	2
Changes to Features.....	1	Changes to Ordering Guide	4
Changes to Applications	1	Changes to Absolute Maximum Ratings.....	4
Changes to General Description	1	New TPCs 3, 4, 7, 8, 11, 12, 15, 16, 19, and 20	6
Changes to Table 1.....	1	New Figures 4 and 5.....	13
Changes to ADR390—Specifications.....	3	Deleted A Negative Precision Reference without Precision Resistors Section	13
Changes to ADR391—Specifications.....	4	Edits to General-Purpose Current Source Section	13
Changes to ADR392—Specifications.....	5	Updated Outline Dimensions	15
Changes to ADR395—Specifications.....	6	5/02—Rev. A to Rev. B	
Changes to Absolute Maximum Ratings.....	7	Edits to Layout	Universal
		Changes to Figure 6.....	13

SPECIFICATIONS

ADR390 ELECTRICAL CHARACTERISTICS

$V_{IN} = 2.5\text{ V to }15\text{ V}$, $T_A = 25^\circ\text{C}$, unless otherwise noted.

Table 2.

Parameter	Symbol	Conditions	Min	Typ	Max	Unit
OUTPUT VOLTAGE	V_O	A grade	2.042	2.048	2.054	V
	V_O	B grade	2.044	2.048	2.052	V
INITIAL ACCURACY	V_{OERR}	A grade			6	mV
	V_{OERR}	A grade			0.29	%
	V_{OERR}	B grade			4	mV
	V_{OERR}	B grade			0.19	%
TEMPERATURE COEFFICIENT	TCV_O	A grade: $-40^\circ\text{C} < T_A < +125^\circ\text{C}$			25	ppm/ $^\circ\text{C}$
		B grade: $-40^\circ\text{C} < T_A < +125^\circ\text{C}$			9	ppm/ $^\circ\text{C}$
SUPPLY VOLTAGE HEADROOM	$V_{IN} - V_O$		300			mV
LINE REGULATION	$\Delta V_O / \Delta V_{IN}$	$V_{IN} = 2.5\text{ V to }15\text{ V}$, $-40^\circ\text{C} < T_A < +125^\circ\text{C}$		10	25	ppm/V
LOAD REGULATION	$\Delta V_O / \Delta I_{LOAD}$	$I_{LOAD} = 0\text{ mA to }5\text{ mA}$, $-40^\circ\text{C} < T_A < +85^\circ\text{C}$, $V_{IN} = 3\text{ V}$			60	ppm/mA
		$I_{LOAD} = 0\text{ mA to }5\text{ mA}$, $-40^\circ\text{C} < T_A < +125^\circ\text{C}$, $V_{IN} = 3\text{ V}$			140	ppm/mA
QUIESCENT CURRENT	I_{IN}	No load $-40^\circ\text{C} < T_A < +125^\circ\text{C}$			120	μA
					140	μA
VOLTAGE NOISE	e_{np-p}	0.1 Hz to 10 Hz		5		$\mu\text{V p-p}$
TURN-ON SETTLING TIME	t_R			20		μs
LONG-TERM STABILITY ¹	ΔV_O	1000 hours		50		ppm
OUTPUT VOLTAGE HYSTERESIS	ΔV_{O_HYS}			100		ppm
RIPPLE REJECTION RATIO	RRR	$f_{IN} = 60\text{ Hz}$		-80		dB
SHORT CIRCUIT TO GND	I_{SC}	$V_{IN} = 5\text{ V}$		25		mA
		$V_{IN} = 15\text{ V}$		30		mA
SHUTDOWN PIN			2.4		3	μA
					500	nA
					0.8	V
						V

¹ The long-term stability specification is noncumulative. The drift of subsequent 1000 hour periods is significantly lower than in the first 1000 hour period.

ADR390/ADR391/ADR392/ADR395

ADR391 ELECTRICAL CHARACTERISTICS

$V_{IN} = 2.8 \text{ V to } 15 \text{ V}$, $T_A = 25^\circ\text{C}$, unless otherwise noted.

Table 3.

Parameter	Symbol	Conditions	Min	Typ	Max	Unit
OUTPUT VOLTAGE	V_O	A grade	2.494	2.5	2.506	V
	V_O	B grade	2.496	2.5	2.504	V
INITIAL ACCURACY	V_{OERR}	A grade			6	mV
	V_{OERR}	A grade			0.24	%
	V_{OERR}	B grade			4	mV
	V_{OERR}	B grade			0.16	%
TEMPERATURE COEFFICIENT	TCV_O	A grade, $-40^\circ\text{C} < T_A < +125^\circ\text{C}$			25	ppm/ $^\circ\text{C}$
		B grade, $-40^\circ\text{C} < T_A < +125^\circ\text{C}$			9	ppm/ $^\circ\text{C}$
SUPPLY VOLTAGE HEADROOM	$V_{IN} - V_O$		300			mV
LINE REGULATION	$\Delta V_O / \Delta V_{IN}$	$V_{IN} = 2.8 \text{ V to } 15 \text{ V}$, $-40^\circ\text{C} < T_A < +125^\circ\text{C}$		10	25	ppm/V
LOAD REGULATION	$\Delta V_O / \Delta I_{LOAD}$	$I_{LOAD} = 0 \text{ mA to } 5 \text{ mA}$, $-40^\circ\text{C} < T_A < +85^\circ\text{C}$, $V_{IN} = 3 \text{ V}$			60	ppm/mA
		$I_{LOAD} = 0 \text{ mA to } 5 \text{ mA}$, $-40^\circ\text{C} < T_A < +125^\circ\text{C}$, $V_{IN} = 3 \text{ V}$			140	ppm/mA
QUIESCENT CURRENT	I_{IN}	No load			120	μA
		$-40^\circ\text{C} < T_A < +125^\circ\text{C}$			140	μA
VOLTAGE NOISE	e_{np-p}	0.1 Hz to 10 Hz		5		$\mu\text{V p-p}$
TURN-ON SETTLING TIME	t_R			20		μs
LONG-TERM STABILITY ¹	ΔV_O	1000 hours		50		ppm
OUTPUT VOLTAGE HYSTERESIS	ΔV_{O_HYS}			100		ppm
RIPPLE REJECTION RATIO	RRR	$f_{IN} = 60 \text{ Hz}$		-80		dB
SHORT CIRCUIT TO GND	I_{SC}	$V_{IN} = 5 \text{ V}$			25	mA
		$V_{IN} = 15 \text{ V}$			30	mA
SHUTDOWN PIN						
Shutdown Supply Current	I_{SHDN}				3	μA
Shutdown Logic Input Current	I_{LOGIC}				500	nA
Shutdown Logic Low	V_{INL}				0.8	V
Shutdown Logic High	V_{INH}		2.4			V

¹ The long-term stability specification is noncumulative. The drift of subsequent 1000 hour periods is significantly lower than in the first 1000 hour period.

ADR392 ELECTRICAL CHARACTERISTICS

$V_{IN} = 4.3\text{ V to }15\text{ V}$, $T_A = 25^\circ\text{C}$, unless otherwise noted.

Table 4.

Parameter	Symbol	Conditions	Min	Typ	Max	Unit				
OUTPUT VOLTAGE	V_O	A grade	4.090	4.096	4.102	V				
	V_O	B grade	4.091	4.096	4.101	V				
INITIAL ACCURACY	V_{OERR}	A grade			6	mV				
	V_{OERR}	A grade			0.15	%				
	V_{OERR}	B grade			5	mV				
	V_{OERR}	B grade			0.12	%				
TEMPERATURE COEFFICIENT	TCV_O	A grade, $-40^\circ\text{C} < T_A < +125^\circ\text{C}$			25	ppm/ $^\circ\text{C}$				
		B grade, $-40^\circ\text{C} < T_A < +125^\circ\text{C}$			9	ppm/ $^\circ\text{C}$				
SUPPLY VOLTAGE HEADROOM	$V_{IN} - V_O$		300			mV				
LINE REGULATION	$\Delta V_O / \Delta V_{IN}$	$V_{IN} = 4.3\text{ V to }15\text{ V}$, $-40^\circ\text{C} < T_A < +125^\circ\text{C}$		10	25	ppm/V				
LOAD REGULATION	$\Delta V_O / \Delta I_{LOAD}$	$I_{LOAD} = 0\text{ mA to }5\text{ mA}$, $-40^\circ\text{C} < T_A < +125^\circ\text{C}$, $V_{IN} = 5\text{ V}$			140	ppm/mA				
QUIESCENT CURRENT	I_{IN}	No load			120	μA				
		$-40^\circ\text{C} < T_A < +125^\circ\text{C}$			140	μA				
VOLTAGE NOISE	e_{NP-P}	0.1 Hz to 10 Hz		7		$\mu\text{V p-p}$				
TURN-ON SETTLING TIME	t_R			20		μs				
LONG-TERM STABILITY ¹	ΔV_O	1000 hours		50		ppm				
OUTPUT VOLTAGE HYSTERESIS	ΔV_{O_HYS}			100		ppm				
RIPPLE REJECTION RATIO	RRR	$f_{IN} = 60\text{ Hz}$		-80		dB				
SHORT CIRCUIT TO GND	I_{SC}	$V_{IN} = 5\text{ V}$			25	mA				
		$V_{IN} = 15\text{ V}$			30	mA				
SHUTDOWN PIN			2.4							
						Shutdown Supply Current	I_{SHDN}		3	μA
						Shutdown Logic Input Current	I_{LOGIC}		500	nA
						Shutdown Logic Low	V_{INL}		0.8	V
Shutdown Logic High	V_{INH}				V					

¹ The long-term stability specification is noncumulative. The drift of subsequent 1000 hour periods is significantly lower than in the first 1000 hour period.

ADR390/ADR391/ADR392/ADR395

ADR395 ELECTRICAL CHARACTERISTICS

$V_{IN} = 5.3 \text{ V to } 15 \text{ V}$, $T_A = 25^\circ\text{C}$, unless otherwise noted.

Table 5.

Parameter	Symbol	Conditions	Min	Typ	Max	Unit
OUTPUT VOLTAGE	V_O	A grade	4.994	5.000	5.006	V
	V_O	B grade	4.995	5.000	5.005	V
INITIAL ACCURACY	V_{OERR}	A grade			6	mV
	V_{OERR}	A grade			0.12	%
	V_{OERR}	B grade			5	mV
	V_{OERR}	B grade			0.10	%
TEMPERATURE COEFFICIENT	TCV_O	A grade, $-40^\circ\text{C} < T_A < +125^\circ\text{C}$			25	ppm/ $^\circ\text{C}$
		B grade, $-40^\circ\text{C} < T_A < +125^\circ\text{C}$			9	ppm/ $^\circ\text{C}$
SUPPLY VOLTAGE HEADROOM	$V_{IN} - V_O$		300			mV
LINE REGULATION	$\Delta V_O / \Delta V_{IN}$	$V_{IN} = 4.3 \text{ V to } 15 \text{ V}$, $-40^\circ\text{C} < T_A < +125^\circ\text{C}$		10	25	ppm/V
LOAD REGULATION	$\Delta V_O / \Delta I_{LOAD}$	$I_{LOAD} = 0 \text{ mA to } 5 \text{ mA}$, $-40^\circ\text{C} < T_A < +125^\circ\text{C}$, $V_{IN} = 6 \text{ V}$			140	ppm/mA
QUIESCENT CURRENT	I_{IN}	No load			120	μA
		$-40^\circ\text{C} < T_A < +125^\circ\text{C}$			140	μA
VOLTAGE NOISE	$e_{n\text{-p-p}}$	0.1 Hz to 10 Hz		8		$\mu\text{V p-p}$
TURN-ON SETTLING TIME	t_R			20		μs
LONG-TERM STABILITY ¹	ΔV_O	1000 hours		50		ppm
OUTPUT VOLTAGE HYSTERESIS	ΔV_{O_HYS}			100		ppm
RIPPLE REJECTION RATIO	RRR	$f_{IN} = 60 \text{ Hz}$		-80		dB
SHORT CIRCUIT TO GND	I_{SC}	$V_{IN} = 5 \text{ V}$		25		mA
		$V_{IN} = 15 \text{ V}$		30		mA
SHUTDOWN PIN						
Shutdown Supply Current	I_{SHDN}				3	μA
Shutdown Logic Input Current	I_{LOGIC}				500	nA
Shutdown Logic Low	V_{INL}				0.8	V
Shutdown Logic High	V_{INH}		2.4			V

¹ The long-term stability specification is noncumulative. The drift of subsequent 1000 hour periods is significantly lower than in the first 1000 hour period.

ABSOLUTE MAXIMUM RATINGS

At 25°C, unless otherwise noted.

Table 6.

Parameter	Rating
Supply Voltage	18 V
Output Short-Circuit Duration to GND	See derating curves
Storage Temperature Range	-65°C to +125°C
Operating Temperature Range	-40°C to +125°C
Junction Temperature Range	-65°C to +125°C
Lead Temperature (Soldering, 60 sec)	300°C

Stresses above those listed under Absolute Maximum Ratings may cause permanent damage to the device. This is a stress rating only; functional operation of the device at these or any other conditions above those indicated in the operational section of this specification is not implied. Exposure to absolute maximum rating conditions for extended periods may affect device reliability.

THERMAL RESISTANCE

θ_{JA} is specified for the worst-case conditions, that is, for a device soldered in a circuit board for surface-mount packages.

Table 7.

Package Type	θ_{JA}	θ_{JC}	Unit
TSOT (UJ-5)	230	146	°C/W

ESD CAUTION



ESD (electrostatic discharge) sensitive device. Charged devices and circuit boards can discharge without detection. Although this product features patented or proprietary protection circuitry, damage may occur on devices subjected to high energy ESD. Therefore, proper ESD precautions should be taken to avoid performance degradation or loss of functionality.

TERMINOLOGY

Temperature Coefficient

The change of output voltage with respect to operating temperature changes normalized by the output voltage at 25°C. This parameter is expressed in ppm/°C and can be determined by the following equation:

$$TCV_o[\text{ppm}/^\circ\text{C}] = \frac{V_o(T_2) - V_o(T_1)}{V_o(25^\circ\text{C}) \times (T_2 - T_1)} \times 10^6 \quad (1)$$

where:

$V_o(25^\circ\text{C})$ is V_o at 25°C.

$V_o(T_1)$ is V_o at Temperature 1.

$V_o(T_2)$ is V_o at Temperature 2.

Line Regulation

The change in output voltage due to a specified change in input voltage. This parameter accounts for the effects of self-heating. Line regulation is expressed in either percent per volt, parts-per-million per volt, or microvolts per volt change in input voltage.

Load Regulation

The change in output voltage due to a specified change in load current. This parameter accounts for the effects of self-heating. Load regulation is expressed in either microvolts per milli-ampere, parts-per-million per milliampere, or ohms of dc output resistance.

Long-Term Stability

Typical shift of output voltage at 25°C on a sample of parts subjected to a test of 1000 hours at 25°C.

$$\Delta V_o = V_o(t_0) - V_o(t_1)$$

$$\Delta V_o[\text{ppm}] = \left(\frac{V_o(t_0) - V_o(t_1)}{V_o(t_0)} \times 10^6 \right) \quad (2)$$

where:

$V_o(t_0)$ is V_o at 25°C at Time 0.

$V_o(t_1)$ is V_o at 25°C after 1000 hours operation at 25°C.

Thermal Hysteresis

The change of output voltage after the device is cycled through temperatures from +25°C to -40°C to +125°C and back to +25°C. This is a typical value from a sample of parts put through such a cycle.

$$V_{o_HYS} = V_o(25^\circ\text{C}) - V_{o_TC} \quad (3)$$

$$V_{o_HYS}[\text{ppm}] = \frac{V_o(25^\circ\text{C}) - V_{o_TC}}{V_o(25^\circ\text{C})} \times 10^6 \quad (4)$$

where:

$V_o(25^\circ\text{C})$ is V_o at 25°C

V_{o_TC} is V_o at 25°C after a temperature cycle from +25°C to -40°C to +125°C and back to +25°C

TYPICAL PERFORMANCE CHARACTERISTICS

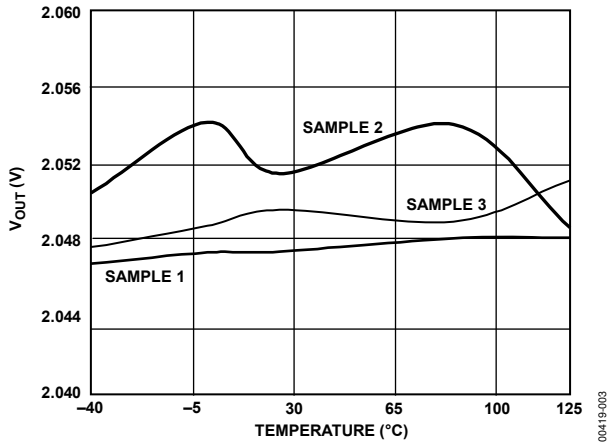

Figure 2. ADR390 Output Voltage vs. Temperature

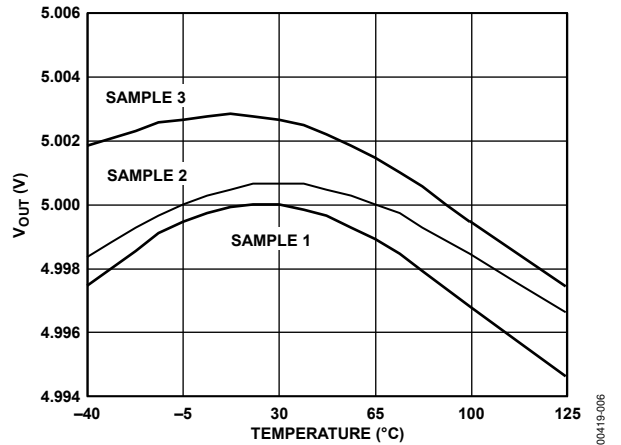

Figure 5. ADR395 Output Voltage vs. Temperature

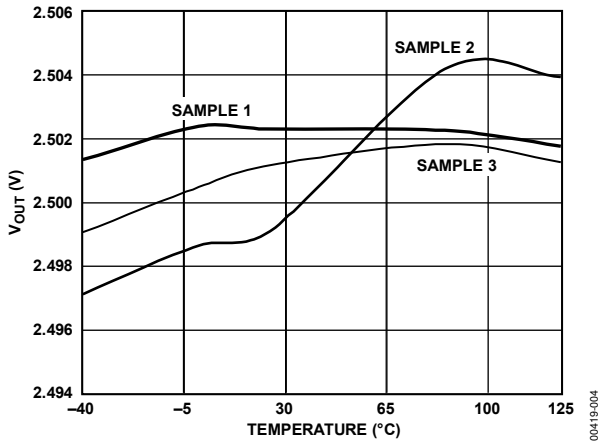

Figure 3. ADR391 Output Voltage vs. Temperature

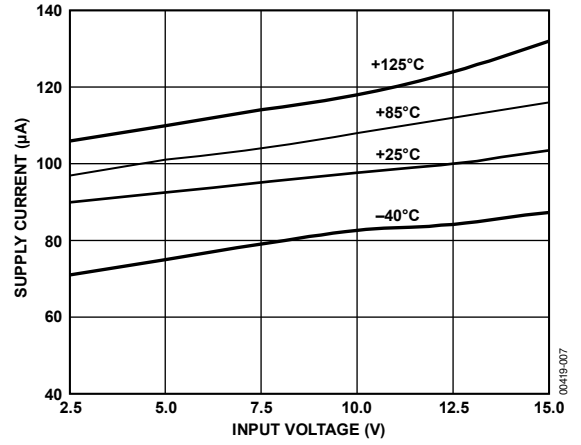

Figure 6. ADR390 Supply Current vs. Input Voltage

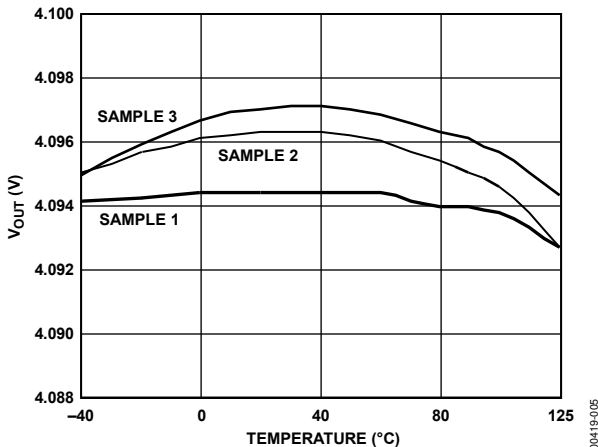

Figure 4. ADR392 Output Voltage vs. Temperature

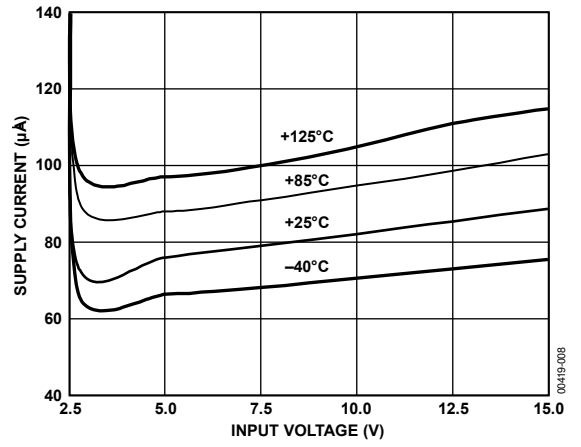

Figure 7. ADR391 Supply Current vs. Input Voltage

ADR390/ADR391/ADR392/ADR395

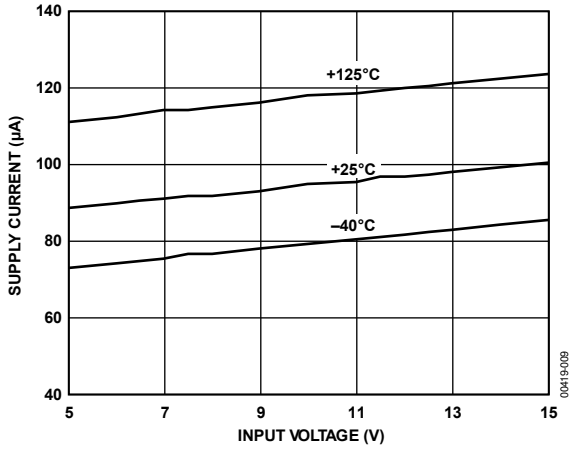

Figure 8. ADR392 Supply Current vs. Input Voltage

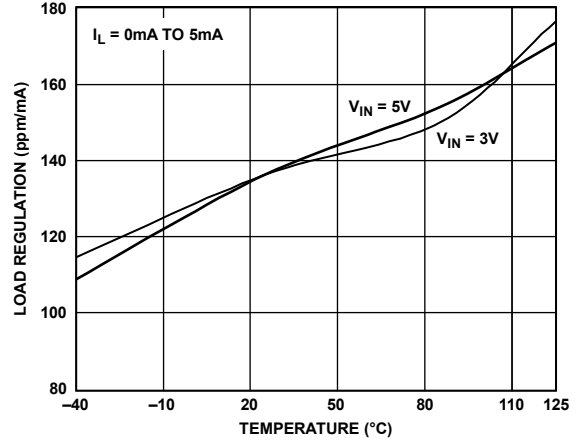

Figure 11. ADR391 Load Regulation vs. Temperature

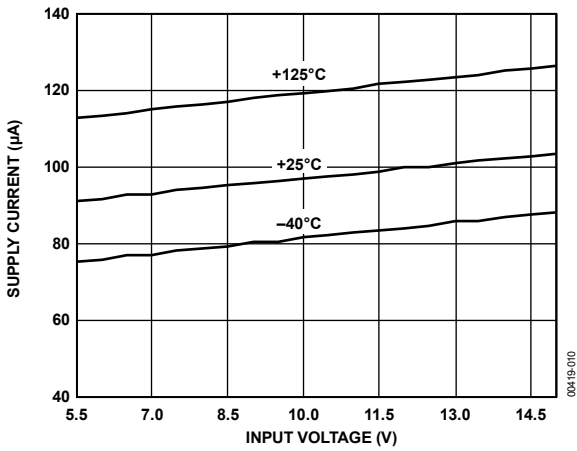

Figure 9. ADR395 Supply Current vs. Input Voltage

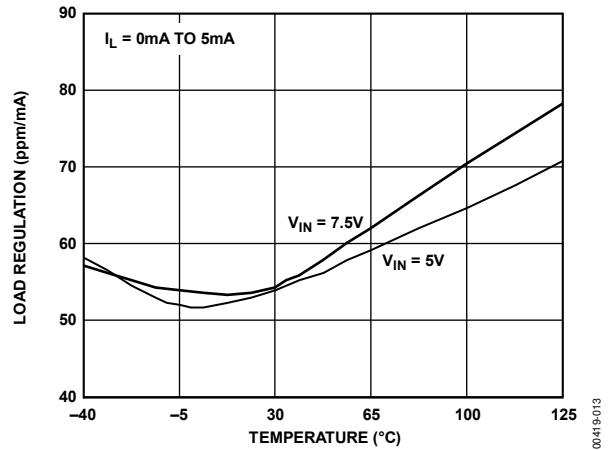

Figure 12. ADR392 Load Regulation vs. Temperature

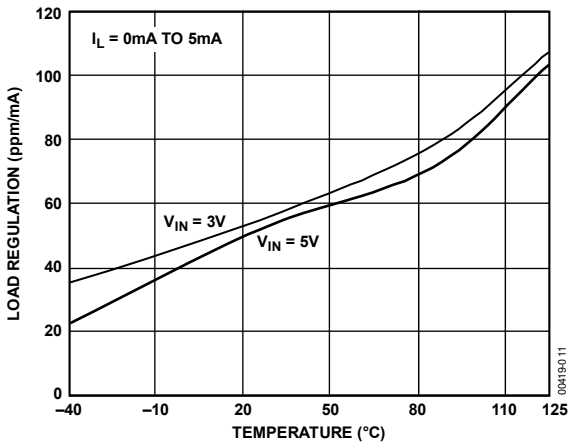

Figure 10. ADR390 Load Regulation vs. Temperature

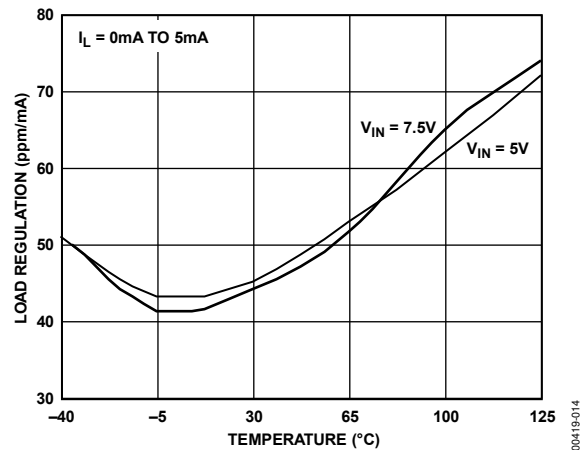

Figure 13. ADR395 Load Regulation vs. Temperature

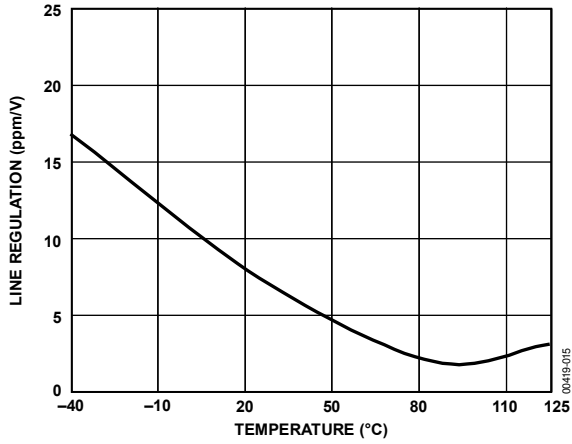

Figure 14. ADR390 Line Regulation vs. Temperature

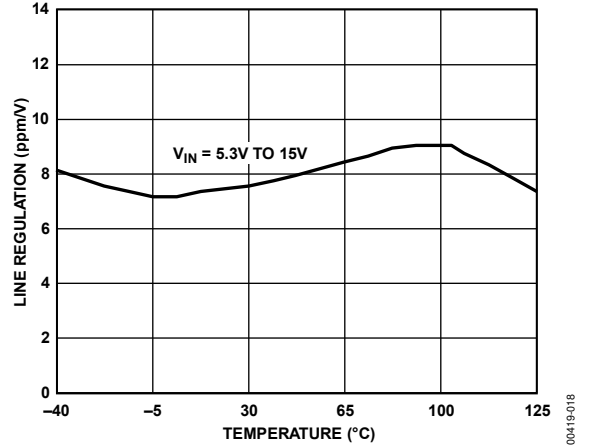

Figure 17. ADR395 Line Regulation vs. Temperature

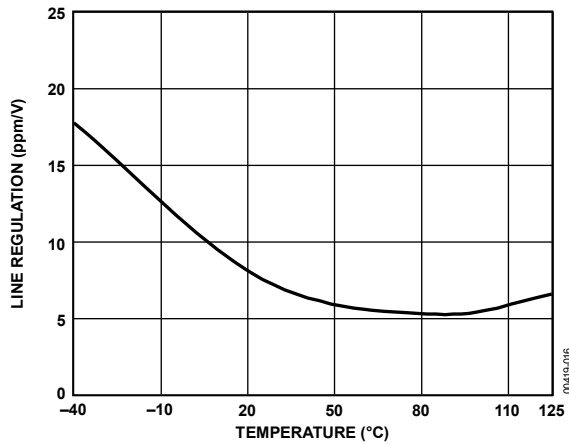

Figure 15. ADR391 Line Regulation vs. Temperature

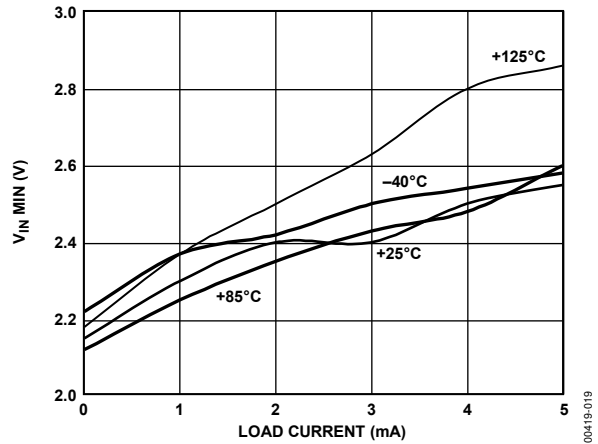

Figure 18. ADR390 Minimum Input Voltage vs. Load Current

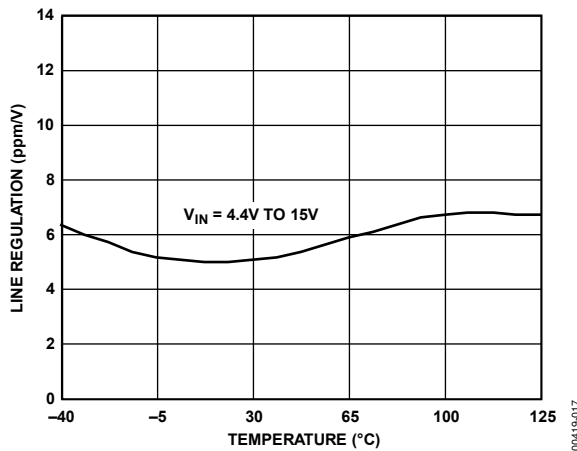

Figure 16. ADR392 Line Regulation vs. Temperature

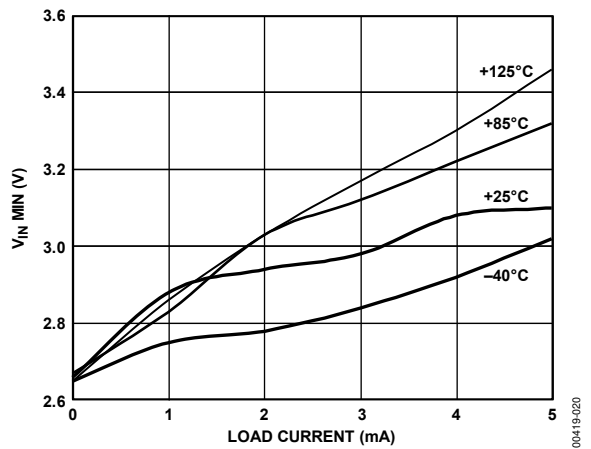

Figure 19. ADR391 Minimum Input Voltage vs. Load Current

ADR390/ADR391/ADR392/ADR395

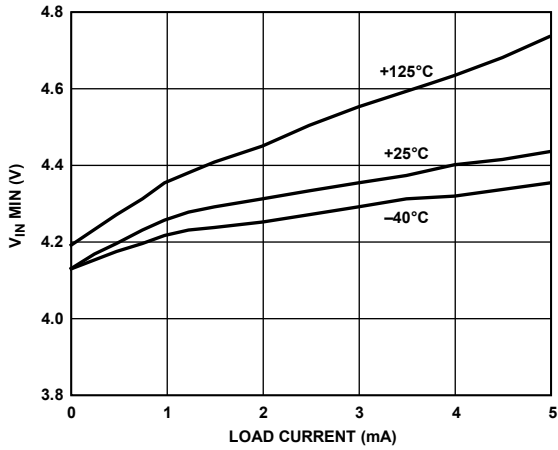

Figure 20. ADR392 Minimum Input Voltage vs. Load Current

00419-021

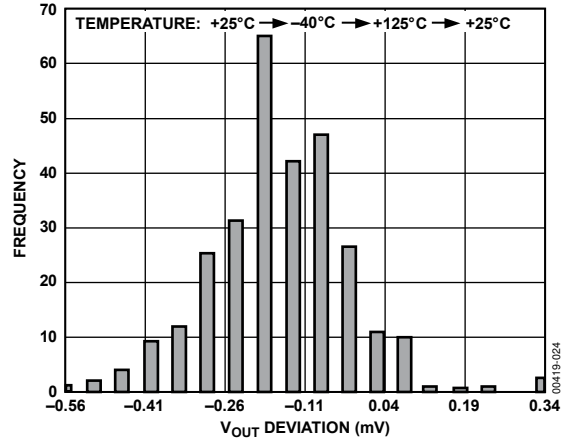

Figure 23. ADR391 V_{OUT} Hysteresis Distribution

00419-024

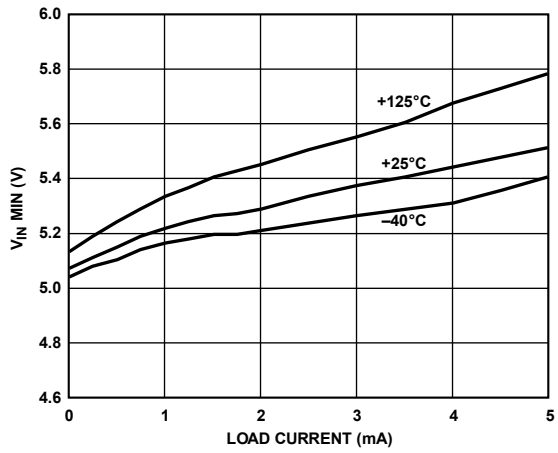

Figure 21. ADR395 Minimum Input Voltage vs. Load Current

00419-022

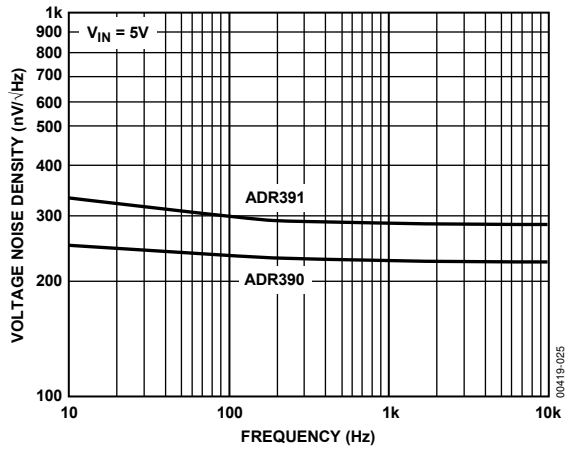

Figure 24. Voltage Noise Density vs. Frequency

00419-025

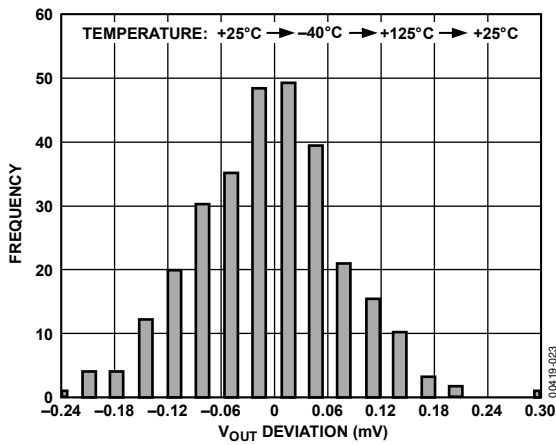

Figure 22. ADR390 V_{OUT} Hysteresis Distribution

00419-023

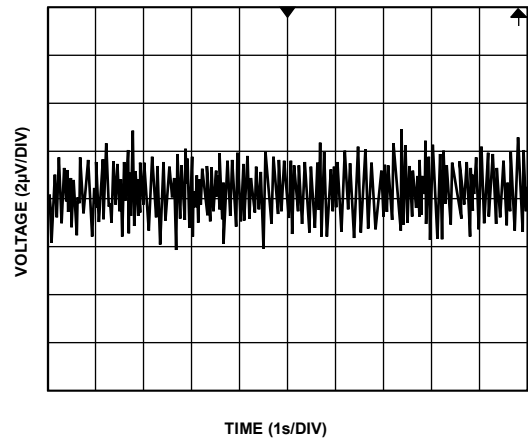

Figure 25. ADR391 Typical Voltage Noise 0.1 Hz to 10 Hz

00419-026

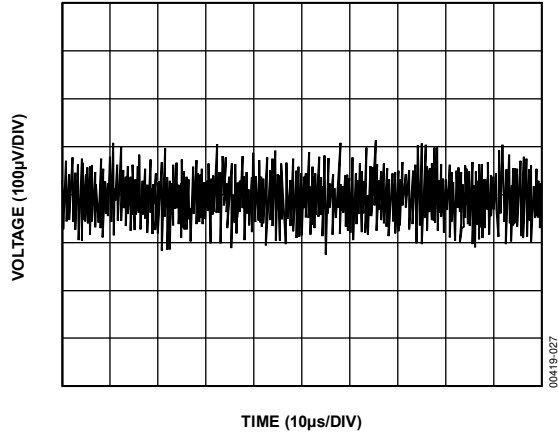

Figure 26. ADR391 Voltage Noise 10 Hz to 10 kHz

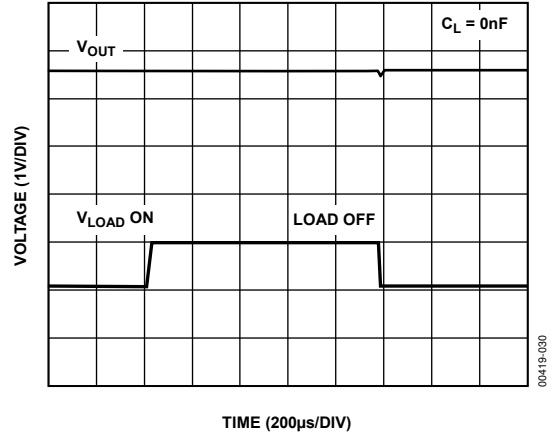

Figure 29. ADR391 Load Transient Response

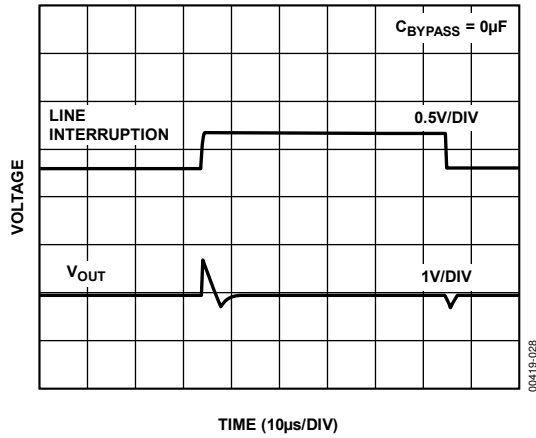

Figure 27. ADR391 Line Transient Response

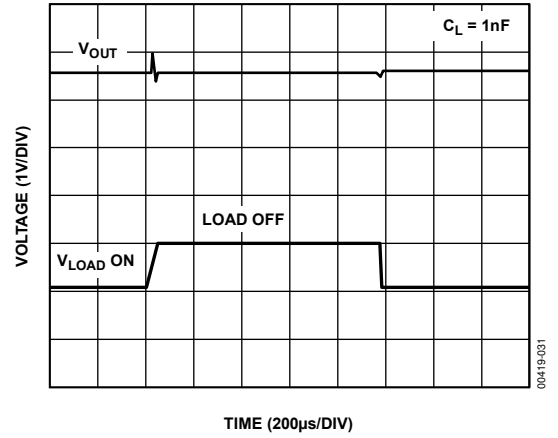

Figure 30. ADR391 Load Transient Response

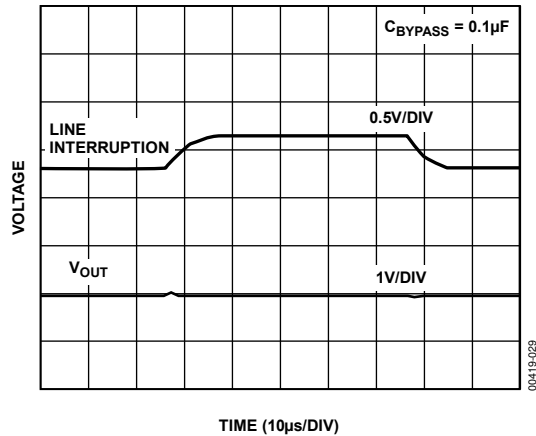

Figure 28. ADR391 Line Transient Response

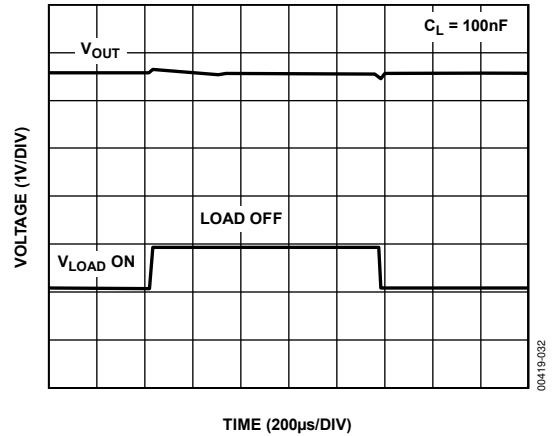

Figure 31. ADR391 Load Transient Response

ADR390/ADR391/ADR392/ADR395

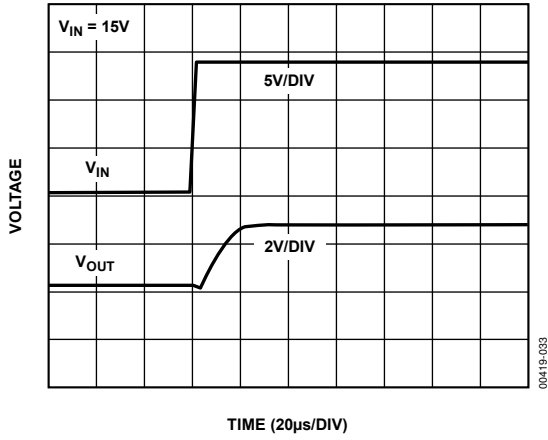

Figure 32. ADR391 Turn-On Response Time at 15 V

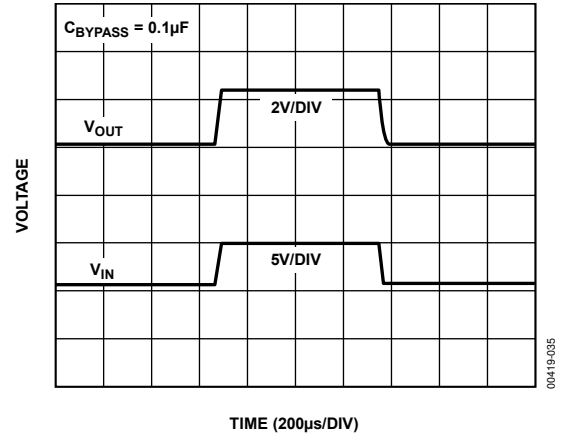

Figure 34. ADR391 Turn-On/Turn-Off Response at 5 V with Capacitance

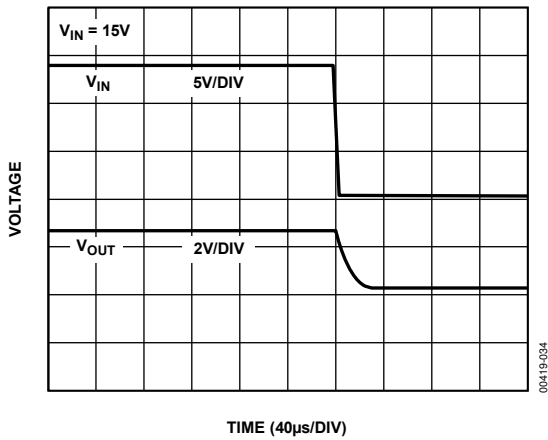

Figure 33. ADR391 Turn-Off Response at 15 V

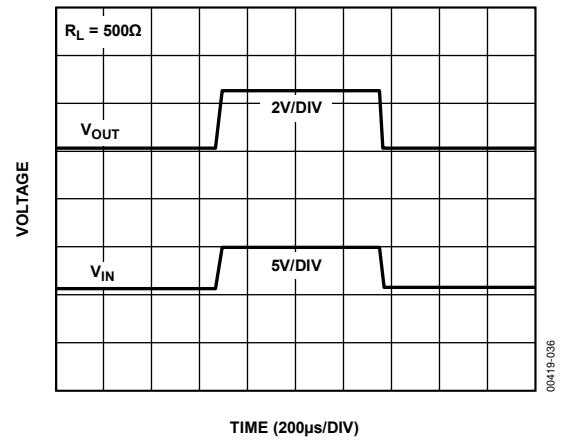

Figure 35. ADR391 Turn-On/Turn-Off Response at 5 V with Resistor Load

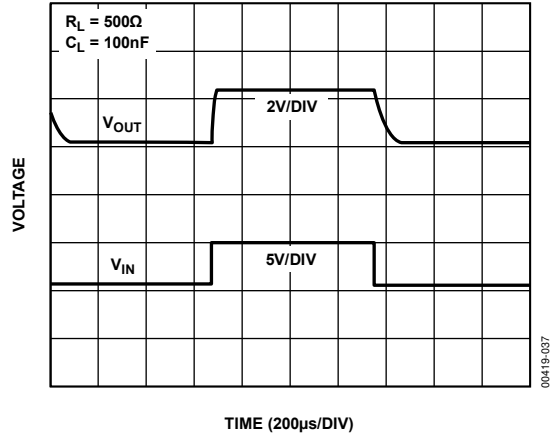

Figure 36. ADR391 Turn-On/Turn-Off Response at 5 V

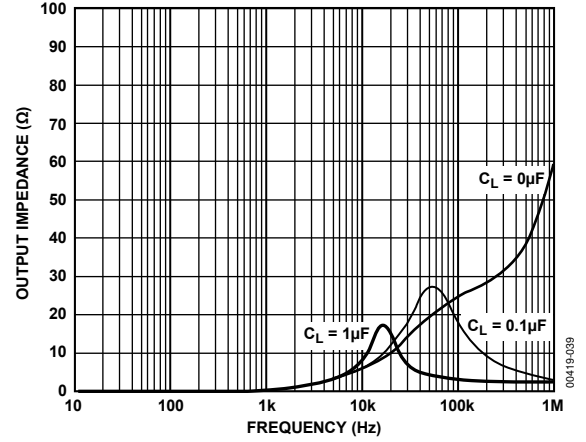

Figure 38. Output Impedance vs. Frequency

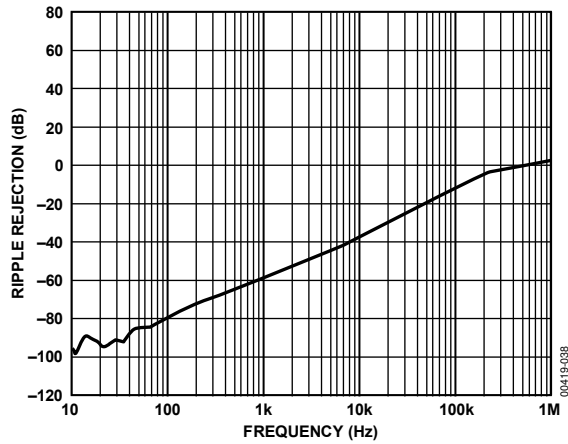

Figure 37. Ripple Rejection vs. Frequency

THEORY OF OPERATION

Band gap references are the high performance solution for low supply voltage and low power voltage reference applications, and the ADR390/ADR391/ADR392/ADR395 are no exception. The uniqueness of these devices lies in the architecture. As shown in Figure 39, the ideal zero TC band gap voltage is referenced to the output, not to ground. Therefore, if noise exists on the ground line, it is greatly attenuated on V_{OUT} . The band gap cell consists of the PNP pair, Q51 and Q52, running at unequal current densities. The difference in V_{BE} results in a voltage with a positive TC, which is amplified by a ratio of

$$2 \times \frac{R58}{R54}$$

This PTAT voltage, combined with V_{BE} s of Q51 and Q52, produces a stable band gap voltage.

Reduction in the band gap curvature is performed by the ratio of Resistors R44 and R59, one of which is linearly temperature dependent. Precision laser trimming and other patented circuit techniques are used to further enhance the drift performance.

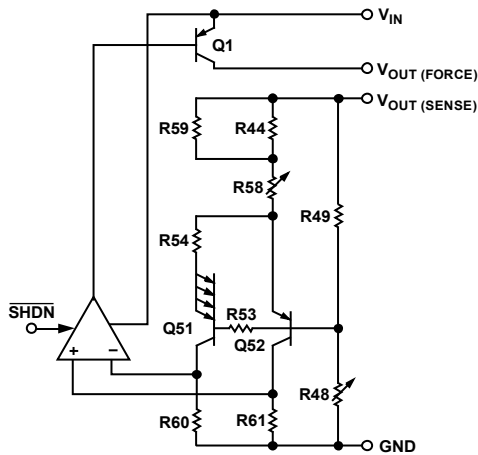

Figure 39. Simplified Schematic

DEVICE POWER DISSIPATION CONSIDERATIONS

The ADR390/ADR391/ADR392/ADR395 are capable of delivering load currents to 5 mA, with an input voltage that ranges from 2.8 V (ADR391 only) to 15 V. When these devices are used in applications with large input voltages, care should be taken to avoid exceeding the specified maximum power dissipation or junction temperature because it could result in premature device failure. The following formula should be used to calculate the maximum junction temperature or dissipation of the device:

$$P_D = \frac{T_J - T_A}{\theta_{JA}} \quad (5)$$

where:

T_J and T_A are, respectively, the junction and ambient temperatures.

P_D is the device power dissipation.

θ_{JA} is the device package thermal resistance.

SHUTDOWN MODE OPERATION

The ADR390/ADR391/ADR392/ADR395 include a shutdown feature that is TTL/CMOS level compatible. A logic low or a zero volt condition on the SHDN pin is required to turn the devices off. During shutdown, the output of the reference becomes a high impedance state, where its potential would then be determined by external circuitry. If the shutdown feature is not used, the SHDN pin should be connected to V_{IN} (Pin 2).

APPLICATIONS INFORMATION

BASIC VOLTAGE REFERENCE CONNECTION

The circuit shown in Figure 40 illustrates the basic configuration for the ADR39x family. Decoupling capacitors are not required for circuit stability. The ADR39x family is capable of driving capacitive loads from 0 μ F to 10 μ F. However, a 0.1 μ F ceramic output capacitor is recommended to absorb and deliver the charge, as required by a dynamic load.

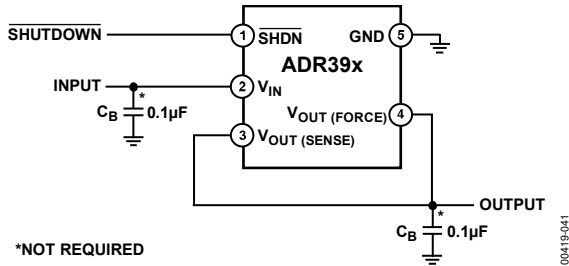

Figure 40. Basic Configuration for the ADR39x Family

Stacking Reference ICs for Arbitrary Outputs

Some applications may require two reference voltage sources, which are a combined sum of standard outputs. Figure 41 shows how this stacked output reference can be implemented.

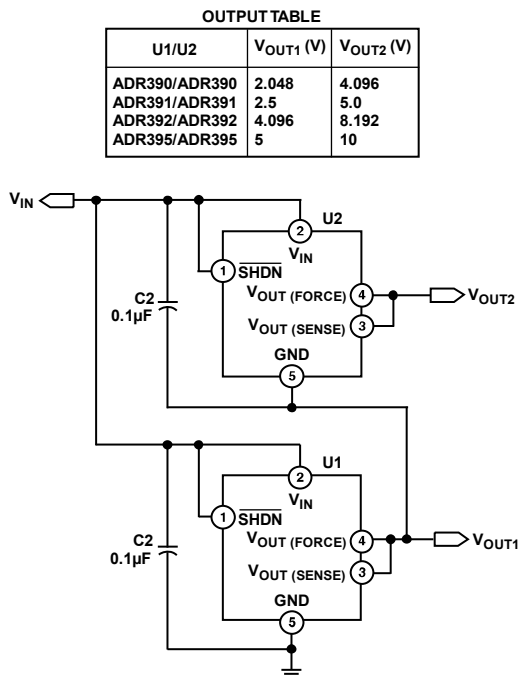

Figure 41. Stacking Voltage References with the ADR390/ADR391/ADR392/ADR395

Two reference ICs are used, fed from an unregulated input, V_{IN} . The outputs of the individual ICs are connected in series, which provide two output voltages, V_{OUT1} and V_{OUT2} . V_{OUT1} is the terminal voltage of U1, while V_{OUT2} is the sum of this voltage and the terminal voltage of U2. U1 and U2 are chosen for the two voltages that supply the required outputs (see the Output

Table in Figure 41). For example, if both U1 and U2 are ADR391s, V_{OUT1} is 2.5 V and V_{OUT2} is 5.0 V.

While this concept is simple, a precaution is required. Because the lower reference circuit must sink a small bias current from U2 plus the base current from the series PNP output transistor in U2, either the external load of U1 or an external resistor must provide a path for this current. If the U1 minimum load is not well defined, the external resistor should be used and set to a value that conservatively passes 600 μ A of current with the applicable V_{OUT1} across it. Note that the two U1 and U2 reference circuits are treated locally as macrocells; each has its own bypasses at input and output for best stability. Both U1 and U2 in this circuit can source dc currents up to their full rating. The minimum input voltage, V_{IN} , is determined by the sum of the outputs, V_{OUT2} , plus the dropout voltage of U2.

A Negative Precision Reference without Precision Resistors

A negative reference can be easily generated by adding an A1 op amp and is configured as shown in Figure 42. $V_{OUT (FORCE)}$ and $V_{OUT (SENSE)}$ are at virtual ground and, therefore, the negative reference can be taken directly from the output of the op amp. The op amp must be dual-supply, low offset, and rail-to-rail if the negative supply voltage is close to the reference output.

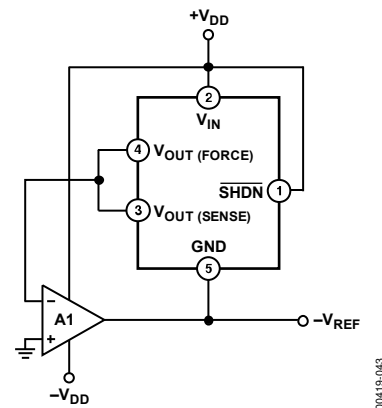

Figure 42. Negative Reference

General-Purpose Current Source

Many times in low power applications, the need arises for a precision current source that can operate on low supply voltages. The ADR390/ADR391/ADR392/ADR395 can be configured as a precision current source. As shown in Figure 43, the circuit configuration is a floating current source with a grounded load. The reference output voltage is bootstrapped across R_{SET} , which sets the output current into the load. With this configuration, circuit precision is maintained for load currents in the range from the reference supply current, typically 90 μ A to approximately 5 mA.

ADR390/ADR391/ADR392/ADR395

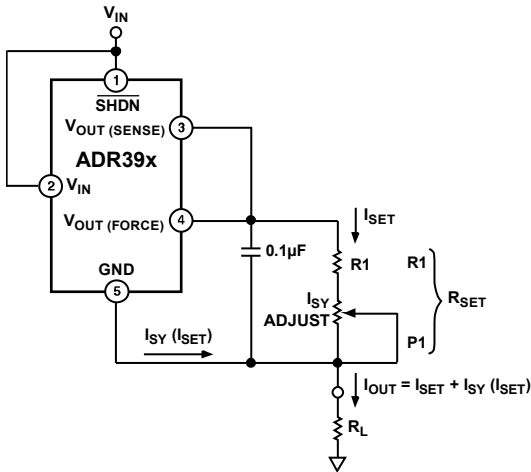

Figure 43. A General-Purpose Current Source

High Power Performance with Current Limit

In some cases, the user may want higher output current delivered to a load and still achieve better than 0.5% accuracy out of the ADR39x. The accuracy for a reference is normally specified on the data sheet with no load. However, the output voltage changes with load current.

The circuit shown in Figure 44 provides high current without compromising the accuracy of the ADR39x. The series pass transistor, Q1, provides up to 1 A load current. The ADR39x delivers only the base drive to Q1 through the force pin. The sense pin of the ADR39x is a regulated output and is connected to the load.

The Transistor Q2 protects Q1 during short-circuit limit faults by robbing its base drive. The maximum current is

$$I_{LMAX} \approx 0.6 V/R_S \quad (6)$$

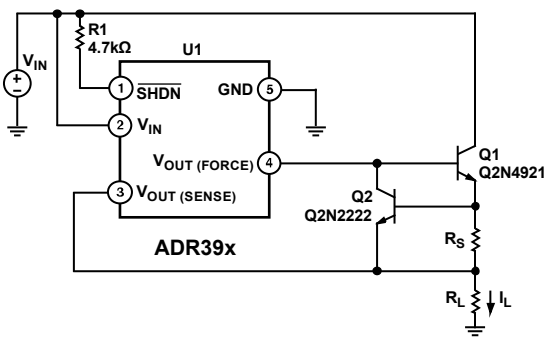

Figure 44. ADR39x for High Power Performance with Current Limit

A similar circuit function can also be achieved with the Darlington transistor configuration, as shown in Figure 45.

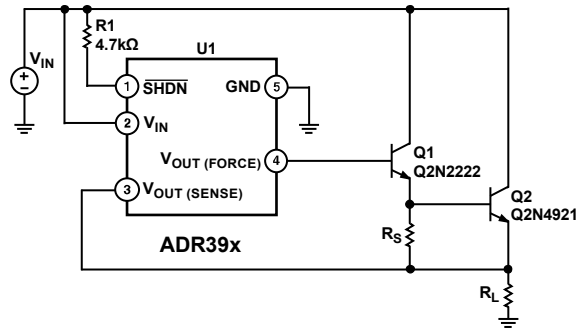

Figure 45. ADR39x for High Output Current with Darlington Drive Configuration

CAPACITORS

Input Capacitor

Input capacitors are not required on the ADR39x. There is no limit for the value of the capacitor used on the input, but a 1 µF to 10 µF capacitor on the input improves transient response in applications where the supply suddenly changes. An additional 0.1 µF in parallel also helps reduce noise from the supply.

Output Capacitor

The ADR39x does not require output capacitors for stability under any load condition. An output capacitor, typically 0.1 µF, filters out any low level noise voltage and does not affect the operation of the part. On the other hand, the load transient response can improve with the addition of a 1 µF to 10 µF output capacitor in parallel. A capacitor here acts as a source of stored energy for a sudden increase in load current. The only parameter that degrades by adding an output capacitor is the turn-on time, and it depends on the size of the capacitor chosen.

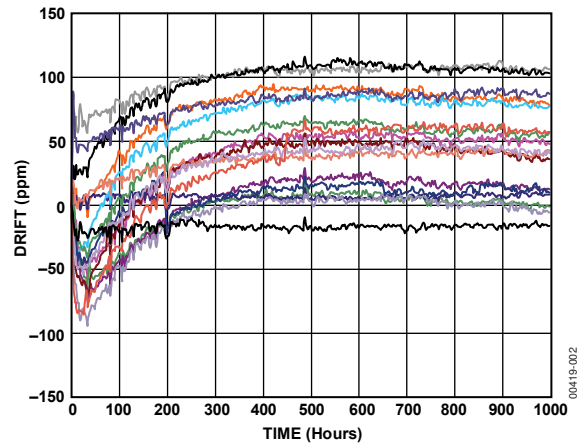
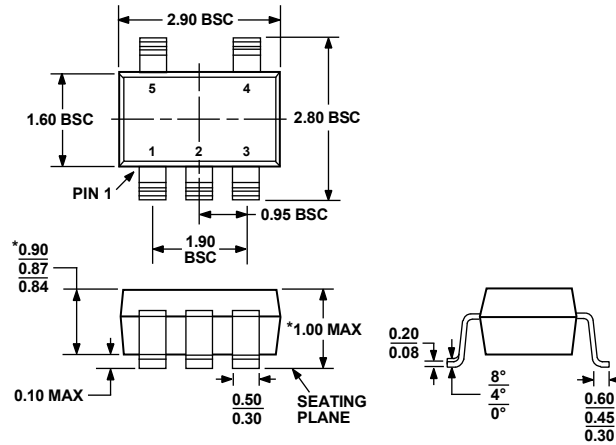

Figure 46. ADR391 Typical Long-Term Drift over 1000 Hours

OUTLINE DIMENSIONS



*COMPLIANT TO JEDEC STANDARDS MO-193-AB WITH THE EXCEPTION OF PACKAGE HEIGHT AND THICKNESS.

Figure 47. 5-Lead Thin Small Outline Transistor Package [TSOT] (UJ-5)
Dimensions shown in millimeters

ORDERING GUIDE

Models	Output Voltage (Vo)	Initial Accuracy (mV) (%)		Temperature Coefficient (ppm/°C)	Package Description	Package Option	Branding	Number of Parts per Reel	Temperature Range
ADR390AUJZ-REEL7 ¹	2.048	±6	0.29	25	5-Lead TSOT	UJ-5	R0A	3,000	-40°C to +125°C
ADR390AUJZ-R2 ¹	2.048	±6	0.29	25	5-Lead TSOT	UJ-5	R0A	250	-40°C to +125°C
ADR390BUJZ-REEL7 ¹	2.048	±4	0.19	9	5-Lead TSOT	UJ-5	R0B	3,000	-40°C to +125°C
ADR390BUJZ-R2 ¹	2.048	±4	0.19	9	5-Lead TSOT	UJ-5	R0B	250	-40°C to +125°C
ADR391AUJZ-REEL7 ¹	2.5	±6	0.24	25	5-Lead TSOT	UJ-5	R1A	3,000	-40°C to +125°C
ADR391AUJZ-R2 ¹	2.5	±6	0.24	25	5-Lead TSOT	UJ-5	R1A	250	-40°C to +125°C
ADR391BUJZ-REEL7 ¹	2.5	±4	0.16	9	5-Lead TSOT	UJ-5	R1B	3,000	-40°C to +125°C
ADR391BUJZ-R2 ¹	2.5	±4	0.16	9	5-Lead TSOT	UJ-5	R1B	250	-40°C to +125°C
ADR392AUJZ-REEL7 ¹	4.096	±6	0.15	25	5-Lead TSOT	UJ-5	RCA	3,000	-40°C to +125°C
ADR392AUJZ-R2 ¹	4.096	±6	0.15	25	5-Lead TSOT	UJ-5	RCA	250	-40°C to +125°C
ADR392BUJZ-REEL7 ¹	4.096	±5	0.12	9	5-Lead TSOT	UJ-5	RCB	3,000	-40°C to +125°C
ADR392BUJZ-R2 ¹	4.096	±5	0.12	9	5-Lead TSOT	UJ-5	RCB	250	-40°C to +125°C
ADR395AUJZ-REEL7 ¹	5.0	±6	0.12	25	5-Lead TSOT	UJ-5	RDA	3,000	-40°C to +125°C
ADR395AUJZ-R2 ¹	5.0	±6	0.12	25	5-Lead TSOT	UJ-5	RDA	250	-40°C to +125°C
ADR395BUJZ-REEL7 ¹	5.0	±5	0.10	9	5-Lead TSOT	UJ-5	RDB	3,000	-40°C to +125°C
ADR395BUJZ-R2 ¹	5.0	±5	0.10	9	5-Lead TSOT	UJ-5	RDB	250	-40°C to +125°C

¹ Z = RoHS Compliant Part.

NOTES