

7-16
NEX10

Adaptor
7-16 Plug – NEX10® Jack

60S189-K00N1

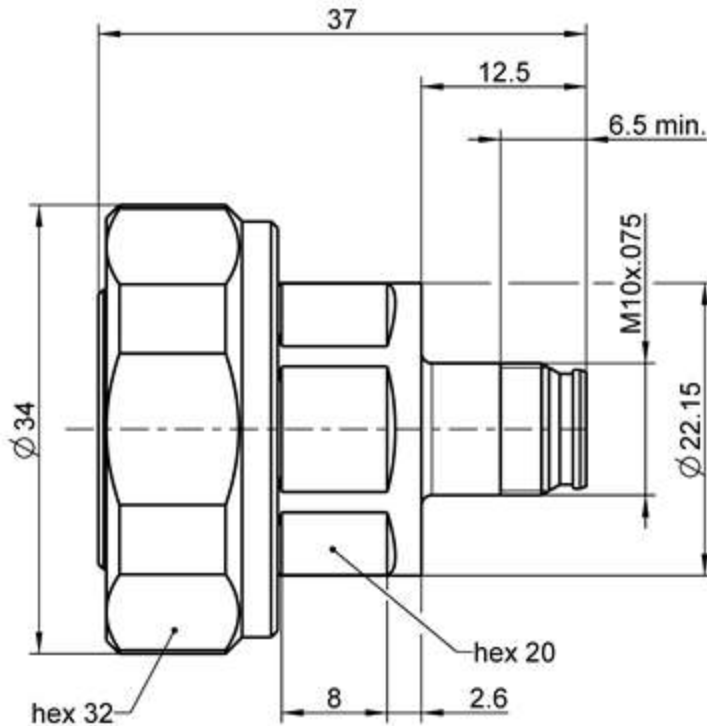

All dimensions are in mm; tolerances according to ISO 2768 m-H

Interface

According to	NEX10 side:	NEX10®
	7-16 side:	IEC 60169-4, VG 95250, EN 122190, DIN 47223

Material and Plating

Connector parts

Center contact	NEX10 side:	Material	Plating
Center contact	7-16 side:	CuBe	Silver, 3-6 µm
Outer contact		Brass	Silver, 3-6 µm
Body		Brass	White bronze(e.g. Optalloy®)
Dielectric		Brass	White bronze(e.g. Optalloy®)
Gasket		PTFE	
		Silicone	

Dieses Dokument ist urheberrechtlich geschützt • This document is protected by copyright • Rosenberger Hochfrequenztechnik GmbH & Co. KG

RFB00035/12.20/6.4

7-16
NEX10

Adaptor
7-16 Plug – NEX10® Jack

60S189-K00N1

Electrical Data

Impedance 50 Ω
 Frequency DC to 8.3 GHz
 Return loss ≥ 32 dB @ DC to 4 GHz
 ≥ 25 dB @ 4 GHz to 6 GHz
 Insertion loss ≤ 0.05 x √ f [GHz] dB
 Insulation resistance ≥ 5 GΩ
 Center contact resistance ≤ 2.0 mΩ, NEX10 side ≤ 0.4 mΩ, 7-16 side
 Outer contact resistance ≤ 1.0 mΩ, NEX10 side ≤ 1.5 mΩ, 7-16 side
 Working voltage 500 V rms
 RF-leakage ≥ 110 dB @ DC to 6 GHz for tool tightened plugs
 ≥ 90 dB @ DC to 3 GHz for tool-less plugs
 ≥ 70 dB @ 3 to 6 GHz for tool-less plugs
 Power handling 100 W @ 2.0 GHz and 85°C ambient temperature
 Intermodulation (3rd order) ≥ 166 dBc (2 x 43 dBm) @ 0.4 – 6.0 GHz

Mechanical Data

	NEX10 side	7-16 side
Mating cycles	≥ 100	min. 500
Recommended torque	1.5 Nm	25 to 30 Nm

Environmental Data

Temperature range -55 °C to +125 °C operating temperature
 Thermal shock IEC 61169-1 9.4.4
 Vibration IEC 61169-1 9.3.3 and IEC 60068-2-64
 Shock IEC 61169-1 9.3.14
 Degree of protection (mated pair) IEC 60529, IP68 24h / 1m
 RoHS compliant

Tooling

N/A

Suitable Cables

N/A

Weight

80 g/pc

While the information has been carefully compiled to the best of our knowledge, nothing is intended as representation or warranty on our part and no statement herein shall be construed as recommendation to infringe existing patents. In the effort to improve our products, we reserve the right to make changes judged to be necessary.

For the installation of the electrotechnical equipment, particular electrotechnical expertise is required.



Draft	Date	Approved	Date	Rev.	Engineering change number	Name	Date
F. Fraunhofer	13.04.2016	Chr. Janßen	02.02.2021	c00	20-1927	B. Wollitzer	02.02.2021
Rosenberger Hochfrequenztechnik GmbH & Co. KG P.O.Box 1260 D-84526 Tittmoning Germany www.rosenberger.com					Tel. : +49 8684 18-0 Email : info@rosenberger.com		Page 2 / 2