

THIS DOCUMENT AND THE DATA DISCLOSED HEREIN OR HEREWITH IS NOT TO BE REPRODUCED, USED, OR DISCLOSED IN WHOLE OR IN PART TO ANYONE WITHOUT PERMISSION OF VICOR CORP.

REV.	DESCRIPTION	DATE	APPROVED
1	RELEASED PER E053463	11/29/05	LEK EF

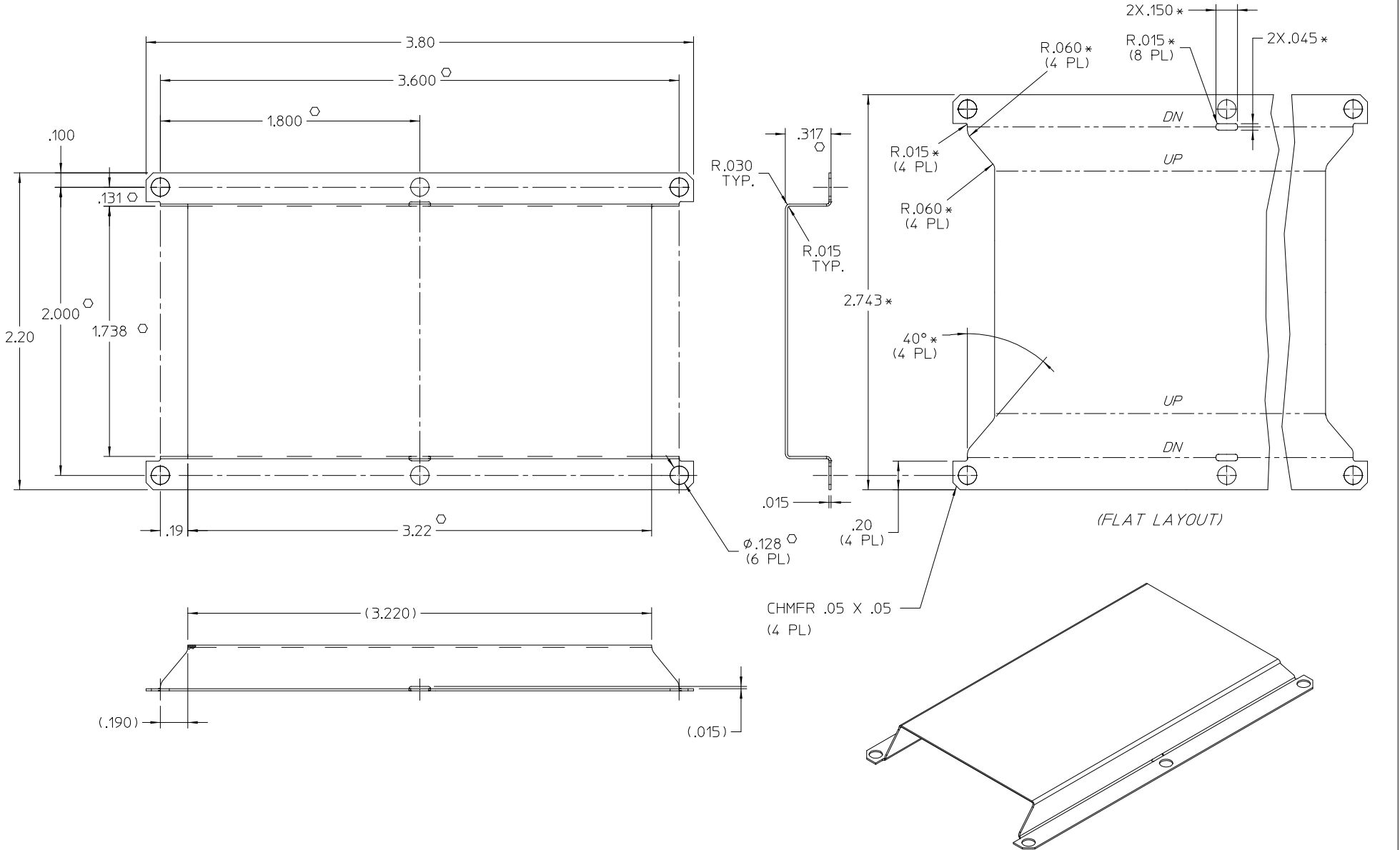

- NOTES:
1. MATERIAL: ALUMINUM- (.015) THK, 5052
  2. REMOVE BURRS & SHARP EDGES
  3. "\*" DIMENSIONS ARE NOT FOR VICOR INSPECTION.
  4. O DENOTES CRITICAL CHARACTERISTICS FOR LOT INSPECTION.
  5. CLEAR FINISH, ROHS COMPLIANT, CHROMIUM FREE PER CST-0001 LATEST REVISION

DRAWN BY <i>P.E.IENI</i>		DATE 05/25/05			
<small>UNLESS OTHERWISE SPECIFIED DIMENSIONS ARE IN INCHES - TOLERANCES ARE:</small> <small>FRACTIONS DECIMALS ANGLES</small> <small>+1/64 .XX+ .01 °1°</small> <small>.XXX-.005</small>					
THIRD ANGLE PROJECTION		SIZE C	FSCM NO. 67131	DWG NO. 30142	REV 1
DO NOT SCALE DRAWING		SCALE X/X	SHEET 1 OF 1		