

M3-L Linear Actuator Smart Module for Precision Motion

FEATURES

- Small
 - Complete, closed-loop system with embedded controls in less than 28 x 13.2 x 7.5 mm
- Precise
 - 0.5 μm resolution
 - 6 mm of travel
- Simple system integration
 - High-level motion commands over standard serial interface (I²C or SPI)
- Flexible system, fast to market
 - Rapidly configurable for push or pull motion
- Low voltage / low power use
 - 3.3 V input, < 500 mW power use
 - Holds position when power is off

High resolution M3-L linear actuators

The M3-L is a miniature high-resolution positioning system with integrated driver and closed-loop control. It delivers 0.5 micron resolution at less than half the size and one-fourth the weight of comparable positioning systems.

This compact, powerful motion system helps OEM designers improve performance and reduce the size of instruments in a wide range of applications. It is ideal for precision tuning of photonics, microwave and RF systems. Defense applications include laser beam steering and targeting, UAV and UGV flight controls, and field-portable systems for biomedical and chemical detection and analysis. Medical applications include micro surgical devices and point-of-care systems.

The M3 micro-mechatronic module platform

M3-L module is built on New Scale's M3 Micro-Mechatronic Module technology platform: the smallest, highest resolution and most repeatable closed-loop micro-mechatronic system available – all in an easily integrated, customizable package. The platform includes a patented SQUIGGLE® RV piezo micro motor, an NSD-2101 drive ASIC, an NSE-5310 high-resolution magnetic position sensor, a microprocessor and firmware. The modules operate on 3.3V input and accept simple high-level motion commands via standard serial interface.



APPLICATIONS

- High Resolution Tuning Systems
- Hand-Held Instrumentation
- Precision Photonics
- Targeting Systems
- UAV/UGV Controls and Optics
- Miniature Camera Systems
- Micro Surgical Devices
- Biomedical Inspection/Sampling

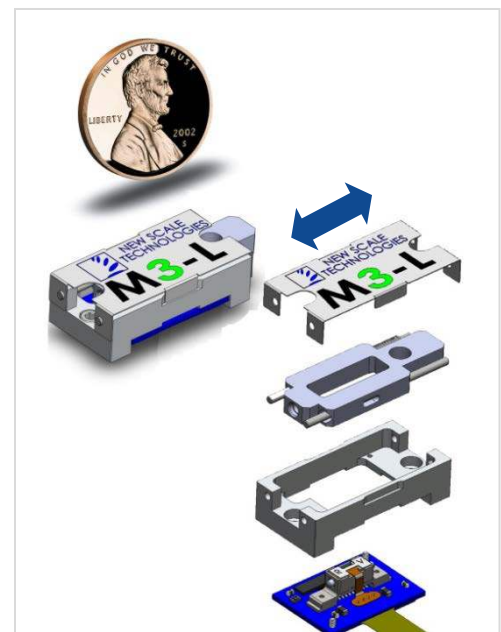

The M3-L linear actuator is a drop-in, sub-micron linear actuator system that meets the most demanding motion control requirements. These modules are easily configured for push or pull motion.

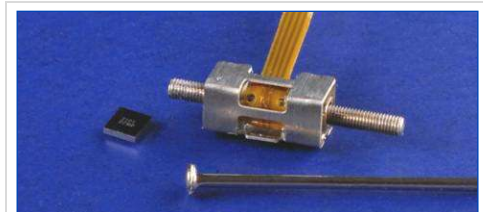

SQUIGGLE RV motor and driver inside every M3-L module: the world's smallest linear motor system.

M3-L Developer's Kits

M3-L Developer's Kits offer convenience for initial evaluation, system development and integration into your prototype. Kits include an M3-L linear smart actuator and a USB adapter to convert motion commands from the New Scale Pathway™ PC software into SPI commands for the linear module. The Developer's Kit module features both a bullet-nose tip for pushing and an eye-end for pulling.

M3-L Linear Actuator Modules

New Scale offers standard and custom M3-L Linear Actuators. For custom module development, contact New Scale Technologies.

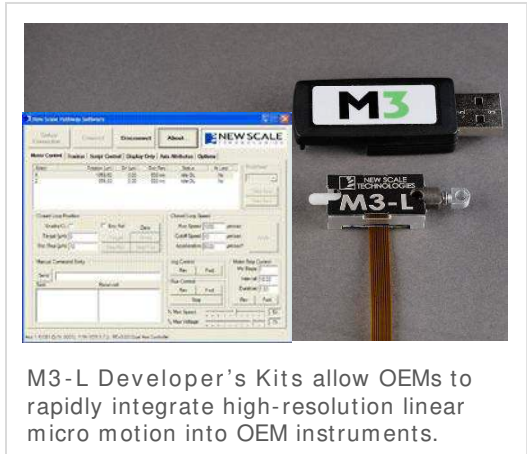

M3-L Developer's Kits allow OEMs to rapidly integrate high-resolution linear micro motion into OEM instruments.

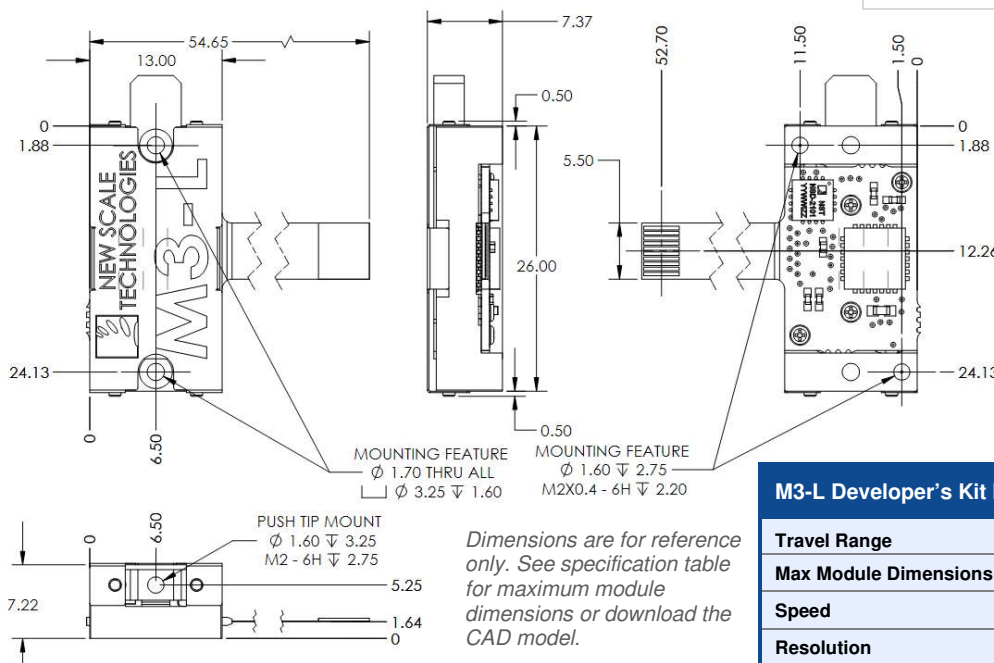

Push Configuration

Compression Force
< 0.2N



Pull Configuration

Tension Force
< 0.2N



M3-L Developer's Kit Module Specifications

Travel Range	6 mm
Max Module Dimensions	28 x 13.2 x 7.5 mm
Speed	5 mm/s @ 0.15 N load (typical)
Resolution	0.5 µm
Linear Accuracy	± 25 µm
Max Load (Push Pull Stall Force with ± 1 degree axial alignment)	<0.20 Newtons
Max Recommended Mass	5 grams
Input Voltage	3.1 - 3.6 V DC
Input Power*	< 0.5 W (5mm/s at 0.15 Newtons) < 0.2 W quiescent
Operating Temperature**	5°C (lower possible) to 70°C
Compliance	CE / RoHS
Digital Interface	I ² C or SPI (embedded controller)
Weight (without tip)	4.5 grams

* Power depends on input voltage, speed & load.

** Contact factory for lower temperature requirements.

Integration and Stages

The **M3-L is a linear actuator** and requires careful attention to loading under static and dynamic conditions. For more information including integration guide and CAD file see <https://www.newscaletech.com/downloads/please-register/>

If you are developing or buying a translation stage to use with the M3-L actuator, consider the **M3-LS Linear Smart Stage** instead. This precision microstage has very high lateral stability, very low and uniform friction, and built-in absolute encoding. The actuator and controller are built into the stage for smallest size and optimal performance. See <https://www.newscaletech.com/micro-motion-modules/m3-ls-linear-smart-stages/>

Ordering information

Visit our website at <https://www.newscaletech.com/micro-motion-modules/m3-l-linear-smart-actuators/>

Part Number	Description
DK-M3-L -1.8-TRK-6.0-S	M3-L Linear Actuator developer's kit. Includes M3-L module with push and pull ends, USB adapter (SPI), connecting cables, mounting hardware and New Scale Pathway™ development software
M3-L-1.8-6.0	M3-L Linear Actuator with built-in controller