



Dual Remote/Local Temperature Sensors with SMBus Serial Interface

General Description

The MAX6695/MAX6696 are precise, dual-remote, and local digital temperature sensors. They accurately measure the temperature of their own die and two remote diode-connected transistors, and report the temperature in digital form on a 2-wire serial interface. The remote diode is typically the emitter-base junction of a common-collector PNP on a CPU, FPGA, GPU, or ASIC.

The 2-wire serial interface accepts standard system management bus (SMBus) commands such as Write Byte, Read Byte, Send Byte, and Receive Byte to read the temperature data and program the alarm thresholds and conversion rate. The MAX6695/MAX6696 can function autonomously with a programmable conversion rate, which allows control of supply current and temperature update rate to match system needs. For conversion rates of 2Hz or less, the temperature is represented as 10 bits + sign with a resolution of $\pm 0.125^{\circ}\text{C}$. When the conversion rate is 4Hz, output data is 7 bits + sign with a resolution of $\pm 1^{\circ}\text{C}$. The MAX6695/MAX6696 also include an SMBus timeout feature to enhance system reliability.

Remote temperature sensing accuracy is $\pm 1.5^{\circ}\text{C}$ between $+60^{\circ}\text{C}$ and $+100^{\circ}\text{C}$ with no calibration needed. The MAX6695/MAX6696 measure temperatures from -40°C to $+125^{\circ}\text{C}$. In addition to the SMBus $\overline{\text{ALERT}}$ output, the MAX6695/MAX6696 feature two overtemperature limit indicators ($\overline{\text{OT1}}$ and $\overline{\text{OT2}}$), which are active only while the temperature is above the corresponding programmable temperature limits. The $\overline{\text{OT1}}$ and $\overline{\text{OT2}}$ outputs are typically used for fan control, clock throttling, or system shutdown.

The MAX6695 has a fixed SMBus address. The MAX6696 has nine different pin-selectable SMBus addresses. The MAX6695 is available in a 10-pin μMAX and the MAX6696 is available in a 16-pin QSOP package. Both operate throughout the -40°C to $+125^{\circ}\text{C}$ temperature range.

Applications

Notebook Computers
Desktop Computers
Servers
Workstations
Test and Measurement Equipment

Features

- ◆ Measure One Local and Two Remote Temperatures
- ◆ 11-Bit, $\pm 0.125^{\circ}\text{C}$ Resolution
- ◆ High Accuracy $\pm 1.5^{\circ}\text{C}$ (max) from $+60^{\circ}\text{C}$ to $+100^{\circ}\text{C}$ (Remote)
- ◆ ACPI Compliant
- ◆ Programmable Under/Overtemperature Alarms
- ◆ Programmable Conversion Rate
- ◆ Three Alarm Outputs: $\overline{\text{ALERT}}$, $\overline{\text{OT1}}$, and $\overline{\text{OT2}}$
- ◆ SMBus/I²C-Compatible Interface
- ◆ Compatible with 65nm Process Technology (Y Versions)

Ordering Information

PART	TEMP RANGE	PIN-PACKAGE
MAX6695AUB+	-40°C to $+125^{\circ}\text{C}$	10 μMAX
MAX6695YAUB+	-40°C to $+125^{\circ}\text{C}$	10 μMAX
MAX6696AEE+	-40°C to $+125^{\circ}\text{C}$	16 QSOP
MAX6696YAEE+	-40°C to $+125^{\circ}\text{C}$	16 QSOP

Devices are also available in tape-and-reel packages. Specify tape and reel by adding "T" to the part number when ordering. +Denotes a lead(Pb)-free/RoHS-compliant package.

Typical Operating Circuit

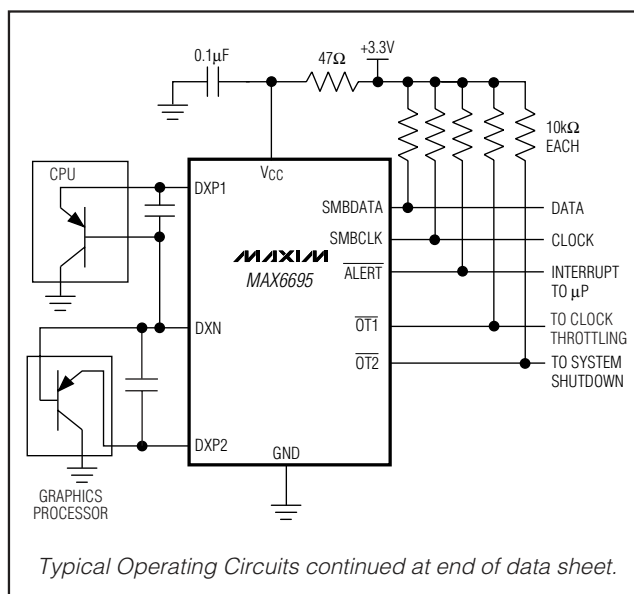

μMAX is a registered trademark of Maxim Integrated Products, Inc.

Pin Configurations appear at end of data sheet.



Maxim Integrated Products 1

For pricing, delivery, and ordering information, please contact Maxim Direct at 1-888-629-4642, or visit Maxim's website at www.maxim-ic.com.

MAX6695/MAX6696

Dual Remote/Local Temperature Sensors with SMBus Serial Interface

ABSOLUTE MAXIMUM RATINGS

V _{CC}	-0.3V to +6V	Continuous Power Dissipation (T _A = +70°C)	
DXP1, DXP2.....	-0.3V to (V _{CC} + 0.3V)	10-Pin μMAX (derate 6.9mW/°C above +70°C).....	555.6mW
DXN.....	-0.3V to +0.8V	16-Pin QSOP (derate 8.3mW/°C above +70°C).....	666.7mW
SMBCLK, SMBDATA, ALERT.....	-0.3V to +6V	Operating Temperature Range.....	-40°C to +125°C
RESET, STBY, ADD0, ADD1, OT1, OT2.....	-0.3V to +6V	Junction Temperature.....	+150°C
SMBDATA Current.....	1mA to 50mA	Storage Temperature Range.....	-65°C to +150°C
DXN Current.....	±1mA	Lead Temperature (soldering, 10s).....	+300°C
		Soldering Temperature (reflow).....	+260°C

Stresses beyond those listed under "Absolute Maximum Ratings" may cause permanent damage to the device. These are stress ratings only, and functional operation of the device at these or any other conditions beyond those indicated in the operational sections of the specifications is not implied. Exposure to absolute maximum rating conditions for extended periods may affect device reliability.

ELECTRICAL CHARACTERISTICS

(V_{CC} = +3.0V to +3.6V, T_A = 0°C to +125°C, unless otherwise noted. Typical values are at V_{CC} = +3.3V and T_A = +25°C)

PARAMETER	SYMBOL	CONDITIONS	MIN	TYP	MAX	UNITS
Supply Voltage	V _{CC}		3.0		3.6	V
Standby Supply Current		SMBus static, ADC in idle state			10	μA
Operating Current		Interface inactive, ADC active		0.5	1	mA
Average Operating Current		Conversion rate = 0.125Hz		35	70	μA
		Conversion rate = 1Hz		250	500	
		Conversion rate = 4Hz		500	1000	
Remote Temperature Error (Note 1)		T _{RJ} = +25°C to +100°C (T _A = +45°C to +85°C)	-1.5		+1.5	°C
		T _{RJ} = 0°C to +125°C (T _A = +25°C to +100°C)	-3.0		+3.0	
		T _{RJ} = -40°C to +125°C (T _A = 0°C to +125°C)	-5.0		+5.0	
		T _{RJ} = -40°C to +125°C (T _A = -40°C)		+3.0		
Local Temperature Error		T _A = +45°C to +85°C	-2.0		+2.0	°C
		T _A = +25°C to +100°C	-3.0		+3.0	
		T _A = 0°C to +125°C	-4.5		+4.5	
		T _A = -40°C to +125°C		+3.0		
Local Temperature Error (MAX6695Y/MAX6696Y)		T _A = +45°C to +85°C		-3.8		°C
		T _A = +25°C to +100°C		-4.0		
		T _A = 0°C to +125°C		-4.2		
		T _A = -40°C to +125°C		-4.4		
Power-On Reset Threshold		V _{CC} , falling edge (Note 2)	1.3	1.45	1.6	V
POR Threshold Hysteresis				500		mV
Undervoltage Lockout Threshold	UVLO	Falling edge of V _{CC} disables ADC	2.2	2.8	2.95	V
Undervoltage Lockout Hysteresis				90		mV
Conversion Time		Channel 1 rate ≤4Hz, channel 2 / local rate ≤2Hz (conversion rate register ≤05h)	112.5	125	137.5	ms
		Channel 1 rate ≥8Hz, channel 2 / local rate ≥4Hz (conversion rate register ≥06h)	56.25	62.5	68.75	
Remote-Diode Source Current	I _{RJ}	High level	80	100	120	μA
		Low level	8	10	12	

Dual Remote/Local Temperature Sensors with SMBus Serial Interface

MAX6695/MAX6696

ELECTRICAL CHARACTERISTICS (continued)

($V_{CC} = +3.0V$ to $+3.6V$, $T_A = 0^{\circ}C$ to $+125^{\circ}C$, unless otherwise noted. Typical values are at $V_{CC} = +3.3V$ and $T_A = +25^{\circ}C$)

PARAMETER	SYMBOL	CONDITIONS	MIN	TYP	MAX	UNITS
ALERT, $\overline{OT1}$, $\overline{OT2}$						
Output Low Sink Current		$V_{OL} = 0.4V$			6	mA
Output High Leakage Current		$V_{OH} = 3.6V$			1	μA
INPUT PIN, ADD0, ADD1 (MAX6696)						
Logic Input Low Voltage	V_{IL}				0.3	V
Logic Input High Voltage	V_{IH}		2.9			V
INPUT PIN, RESET, STBY (MAX6696)						
Logic Input Low Voltage	V_{IL}				0.8	V
Logic Input High Voltage	V_{IH}		2.1			V
Input Leakage Current	I_{LEAK}		-1		+1	μA
SMBus INTERFACE (SMBCLK, SMBDATA, STBY)						
Logic Input Low Voltage	V_{IL}				0.8	V
Logic Input High Voltage	V_{IH}		2.1			V
Input Leakage Current	I_{LEAK}	$V_{IN} = GND$ or V_{CC}			± 1	μA
Output Low Sink Current	I_{OL}	$V_{OL} = 0.6V$			6	mA
Input Capacitance	C_{IN}			5		pF
SMBus-COMPATIBLE TIMING (Figures 4 and 5) (Note 2)						
Serial Clock Frequency	f_{SCL}		10		100	kHz
Bus Free Time Between STOP and START Condition	t_{BUF}		4.7			μs
Repeat START Condition Setup Time	$t_{SU:STA}$	90% of SMBCLK to 90% of SMBDATA	4.7			μs
START Condition Hold Time	$t_{HD:STA}$	10% of SMBDATA to 90% of SMBCLK	4			μs
STOP Condition Setup Time	$t_{SU:STO}$	90% of SMBCLK to 90% of SMBDATA	4			μs
Clock Low Period	t_{LOW}	10% to 10%	4			μs
Clock High Period	t_{HIGH}	90% to 90%	4.7			μs
Data Setup Time	$t_{SU:DAT}$		250			ns
Data Hold Time	$t_{HD:DAT}$		300			ns
SMB Rise Time	t_R				1	μs
SMB Fall Time	t_F				300	ns
SMBus Timeout		SMBDATA low period for interface reset	20	30	40	ms

Note 1: Based on diode ideality factor of 1.008.

Note 2: Specifications are guaranteed by design, not production tested.

Dual Remote/Local Temperature Sensors with SMBus Serial Interface

Typical Operating Characteristics

($V_{CC} = 3.3V$, $T_A = +25^\circ C$, unless otherwise noted.)

STANDBY SUPPLY CURRENT vs. SUPPLY VOLTAGE

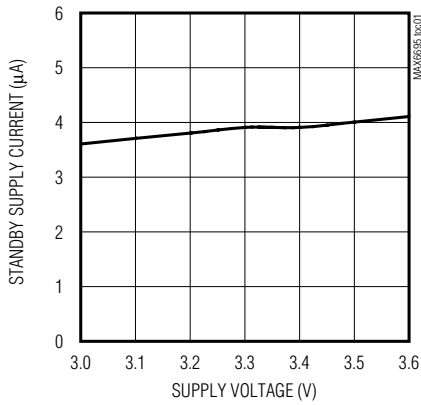

AVERAGE OPERATING SUPPLY CURRENT vs. CONVERSION RATE CONTROL REGISTER VALUE

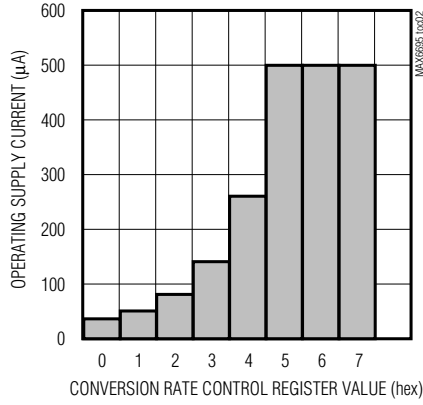

TEMPERATURE ERROR vs. REMOTE-DIODE TEMPERATURE

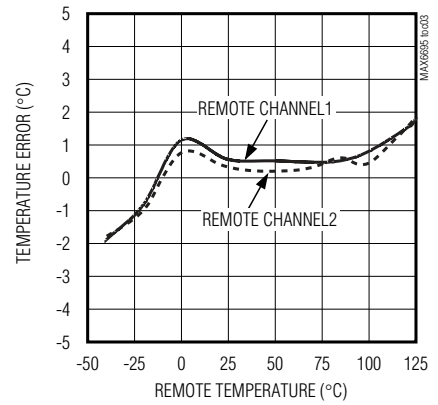

LOCAL TEMPERATURE ERROR vs. DIE TEMPERATURE

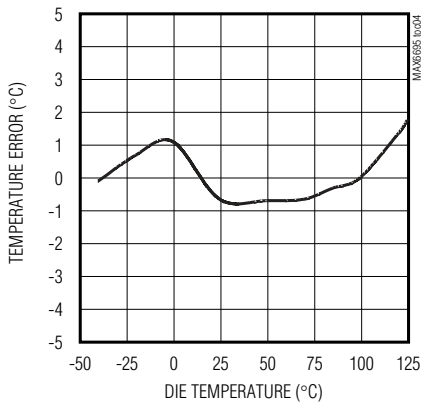

TEMPERATURE ERROR vs. DXP-DXN CAPACITANCE

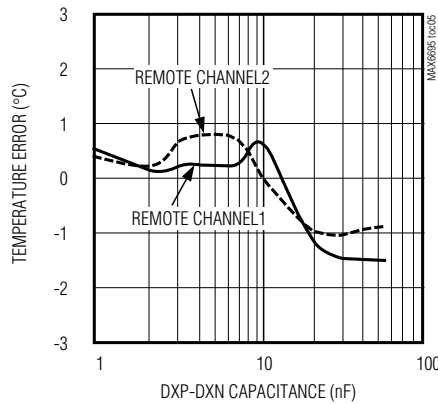

TEMPERATURE ERROR vs. DIFFERENTIAL NOISE FREQUENCY

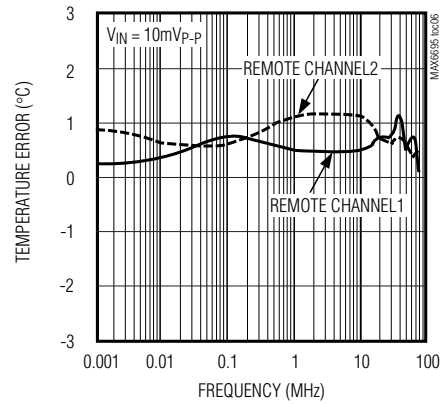

REMOTE TEMPERATURE ERROR vs. POWER-SUPPLY NOISE FREQUENCY

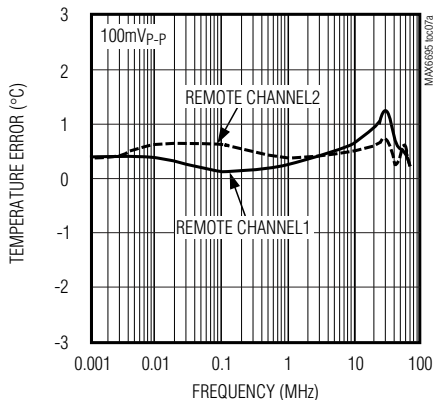

LOCAL TEMPERATURE ERROR vs. POWER-SUPPLY NOISE FREQUENCY

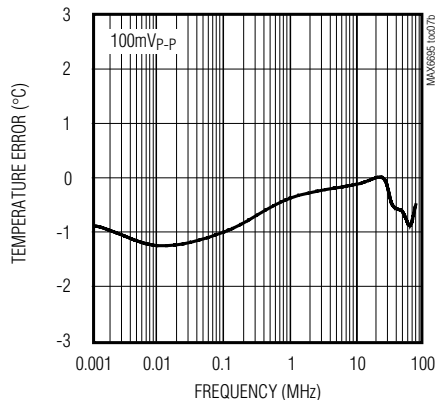

TEMPERATURE ERROR vs. COMMON-MODE NOISE FREQUENCY

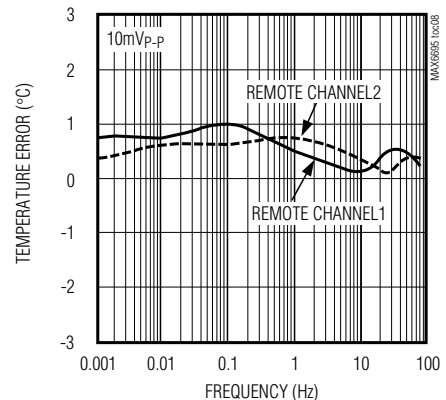

Dual Remote/Local Temperature Sensors with SMBus Serial Interface

Pin Description

PIN		NAME	FUNCTION
MAX6695	MAX6696		
1	2	V _{CC}	Supply Voltage Input, +3V to +3.6V. Bypass to GND with a 0.1μF capacitor. A 47Ω series resistor is recommended but not required for additional noise filtering. See <i>Typical Operating Circuit</i> .
2	3	DXP1	Combined Remote-Diode Current Source and A/D Positive Input for Remote-Diode Channel 1. DO NOT LEAVE DXP1 UNCONNECTED; connect DXP1 to DXN if no remote diode is used. Place a 2200pF capacitor between DXP1 and DXN for noise filtering.
3	4	DXN	Combined Remote-Diode Current Sink and A/D Negative Input. DXN is internally biased to one diode drop above ground.
4	5	DXP2	Combined Remote-Diode Current Source and A/D Positive Input for Remote-Diode Channel 2. DO NOT LEAVE DXP2 UNCONNECTED; connect DXP2 to DXN if no remote diode is used. Place a 2200pF capacitor between DXP2 and DXN for noise filtering.
5	10	$\overline{OT1}$	Overtemperature Active-Low Output, Open Drain. $\overline{OT1}$ is asserted low only when the temperature is above the programmed OT1 threshold.
6	8	GND	Ground
7	9	SMBCLK	SMBus Serial-Clock Input
8	11	\overline{ALERT}	SMBus Alert (Interrupt) Active-Low Output, Open-Drain. Asserts when temperature exceeds user-set limits (high or low temperature) or when a remote sensor opens. Stays asserted until acknowledged by either reading the status register or by successfully responding to an alert response address. See the <i>ALERT Interrupts</i> section.
9	12	SMBDATA	SMBus Serial-Data Input/Output, Open Drain
10	13	$\overline{OT2}$	Overtemperature Active-Low Output, Open Drain. $\overline{OT2}$ is asserted low only when temperature is above the programmed OT2 threshold.
—	1, 16	N.C.	No Connect
—	6	ADD1	SMBus Slave Address Select Input (Table 10). ADD0 and ADD1 are sampled upon power-up.
—	7	RESET	Reset Input. Drive RESET high to set all registers to their default values (POR state). Pull RESET low for normal operation.
—	14	ADD0	SMBus Slave Address Select Input (Table 10). ADD0 and ADD1 are sampled upon power-up.
—	15	\overline{STBY}	Hardware Standby Input. Pull \overline{STBY} low to put the device into standby mode. All registers' data are maintained.

MAX6695/MAX6696

Dual Remote/Local Temperature Sensors with SMBus Serial Interface

Detailed Description

The MAX6695/MAX6696 are temperature sensors designed to work in conjunction with a microprocessor or other intelligence in temperature monitoring, protection, or control applications. Communication with the MAX6695/MAX6696 occurs through the SMBus serial interface and dedicated alert pins. The overtemperature alarms $\overline{OT1}$ and $\overline{OT2}$ are asserted if the software-programmed temperature thresholds are exceeded. $\overline{OT1}$ and $\overline{OT2}$ can be connected to a fan, system shutdown, or other thermal-management circuitry.

The MAX6695/MAX6696 convert temperatures to digital data continuously at a programmed rate or by selecting a single conversion. At the highest conversion rate, temperature conversion results are stored in the “main” temperature data registers (at addresses 00h and 01h) as 7-bit + sign data with the LSB equal to +1°C. At slower conversion rates, 3 additional bits are available at addresses 11h and 10h, providing +0.125°C resolution. See Tables 2, 3, and 4 for data formats.

ADC and Multiplexer

The MAX6695/MAX6696 averaging ADC (Figure 1) integrates over a 62.5ms or 125ms period (each channel, typ), depending on the conversion rate (see *Electrical Characteristics* table). The use of an averaging ADC attains excellent noise rejection.

The MAX6695/MAX6696 multiplexer (Figure 1) automatically steers bias currents through the remote and local diodes. The ADC and associated circuitry measure each diode's forward voltages and compute the temperature based on these voltages. If a remote channel is not used, connect DXP_ to DXN. **Do not leave DXP_ and DXN unconnected.** When a conversion is initiated, all channels are converted whether they are used or not. The DXN input is biased at one V_{BE} above ground by an internal diode to set up the ADC inputs for a differential measurement. Resistance in series with the remote diode causes about +1/2°C error per ohm.

A/D Conversion Sequence

A conversion sequence consists of a local temperature measurement and two remote temperature measurements. Each time a conversion begins, whether initiated automatically in the free-running autoconvert mode (RUN/STOP = 0) or by writing a one-shot command, all three channels are converted, and the results of the three measurements are available after the end of conversion. Because it is common to require temperature measurements to be made at a faster rate on one of the remote channels than on the other two channels, the conversion sequence is Remote 1, Local, Remote 1, Remote 2. Therefore, the Remote 1 conversion rate is

double that of the conversion rate for either of the other two channels.

A BUSY status bit in status register 1 (see Table 7 and the *Status Byte Functions* section) shows that the device is actually performing a new conversion. The results of the previous conversion sequence are always available when the ADC is busy.

Remote-Diode Selection

The MAX6695/MAX6696 can directly measure the die temperature of CPUs and other ICs that have on-board temperature-sensing diodes (see the *Typical Operating Circuit*) or they can measure the temperature of a discrete diode-connected transistor.

Effect of Ideality Factor

The accuracy of the remote temperature measurements depends on the ideality factor (n) of the remote “diode” (actually a transistor). The MAX6695/MAX6696 (not the MAX6695Y/MAX6696Y) are optimized for $n = 1.008$. A thermal diode on the substrate of an IC is normally a PNP with its collector grounded. DXP_ must be connected to the anode (emitter) and DXN must be connected to the cathode (base) of this PNP.

If a sense transistor with an ideality factor other than 1.008 is used, the output data will be different from the data obtained with the optimum ideality factor. Fortunately, the difference is predictable. Assume a remote-diode sensor designed for a nominal ideality factor $n_{NOMINAL}$ is used to measure the temperature of a diode with a different ideality factor n_1 . The measured temperature T_M can be corrected using:

$$T_M = T_{ACTUAL} \times \left(\frac{n_1}{n_{NOMINAL}} \right)$$

where temperature is measured in Kelvin and $n_{NOMINAL}$ for the MAX6695/MAX6696 is 1.008.

As an example, assume you want to use the MAX6695 or MAX6696 with a CPU that has an ideality factor of 1.002. If the diode has no series resistance, the measured data is related to the real temperature as follows:

$$T_{ACTUAL} = T_M \times \left(\frac{n_{NOMINAL}}{n_1} \right) = T_M \times \left(\frac{1.008}{1.002} \right) = T_M \times (1.00599)$$

For a real temperature of +85°C (358.15K), the measured temperature is +82.87°C (356.02K), an error of -2.13°C.

Effect of Series Resistance

Series resistance (R_S) with a sensing diode contributes additional error. For nominal diode currents of 10 μ A

Dual Remote/Local Temperature Sensors with SMBus Serial Interface

MAX6695/MAX6696

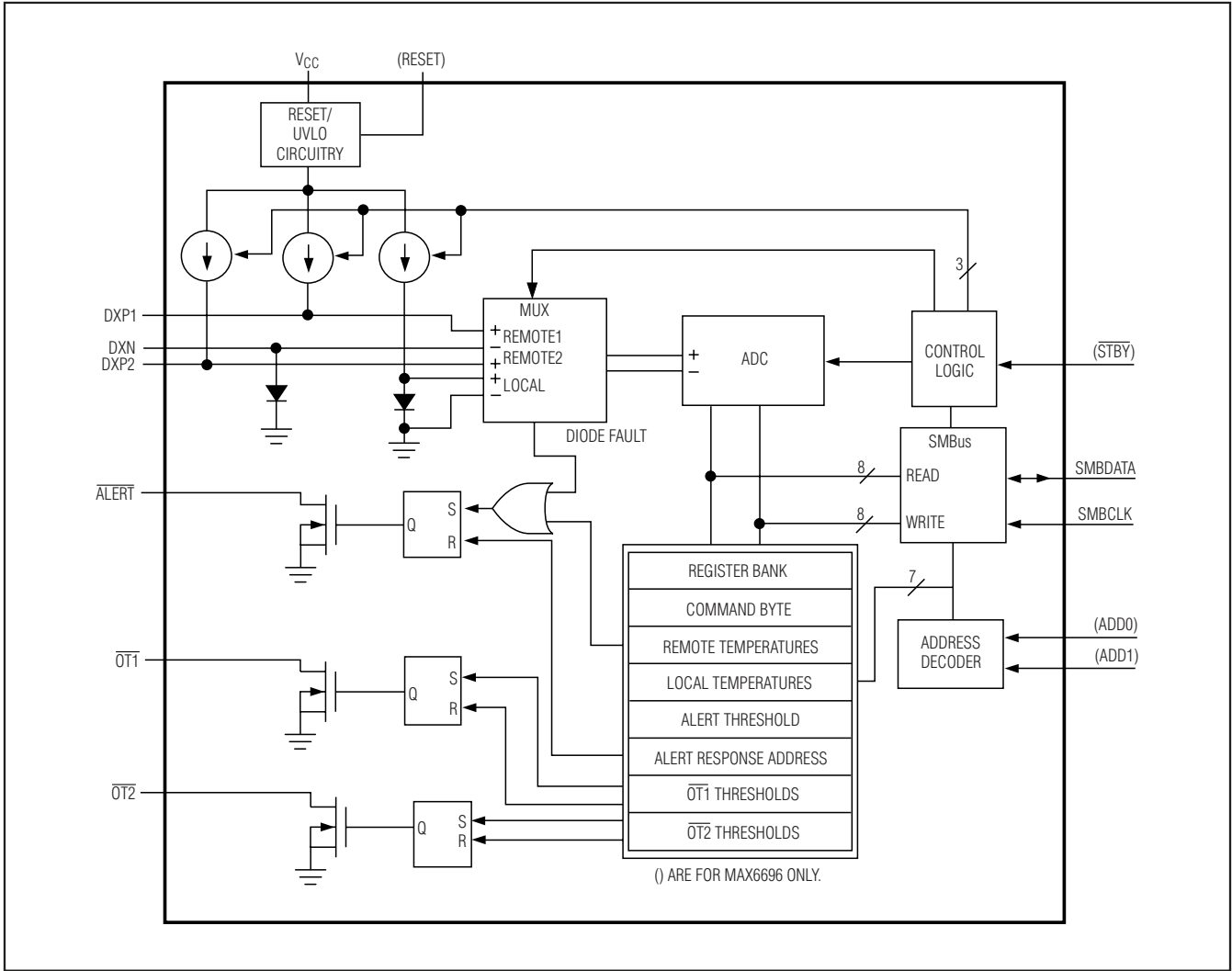

Figure 1. MAX6695/MAX6696 Functional Diagram

and 100µA, the change in the measured voltage due to series resistance is:

$$\Delta V_M = (100\mu A - 10\mu A) \times R_S = 90\mu A \times R_S$$

Since 1°C corresponds to 198.6µV, series resistance contributes a temperature offset of:

$$\frac{90 \frac{\mu V}{\Omega}}{198.6 \frac{\mu V}{^\circ C}} = 0.453 \frac{^\circ C}{\Omega}$$

Assume that the sensing diode being measured has a series resistance of 3Ω. The series resistance contributes a temperature offset of:

$$3\Omega \times 0.453 \frac{^\circ C}{\Omega} = +1.36^\circ C$$

The effects of the ideality factor and series resistance are additive. If the diode has an ideality factor of 1.002 and series resistance of 3Ω, the total offset can be calculated by adding error due to series resistance with error due to ideality factor:

$$1.36^\circ C - 2.13^\circ C = -0.77^\circ C$$

for a diode temperature of +85°C.

Dual Remote/Local Temperature Sensors with SMBus Serial Interface

In this example, the effect of the series resistance and the ideality factor partially cancel each other.

Discrete Remote Diodes

When the remote-sensing diode is a discrete transistor, its collector and base must be connected together. Table 1 lists examples of discrete transistors that are appropriate for use with the MAX6695/MAX6696.

The transistor must be a small-signal type with a relatively high forward voltage; otherwise, the A/D input voltage range can be violated. The forward voltage at the highest expected temperature must be greater than 0.25V at 10 μ A, and at the lowest expected temperature, the forward voltage must be less than 0.95V at 100 μ A. Large power transistors must not be used. Also, ensure that the base resistance is less than 100 Ω . Tight specifications for forward current gain ($50 < \beta < 150$, for example) indicate that the manufacturer has good process controls and that the devices have consistent V_{BE} characteristics.

Manufacturers of discrete transistors do not normally specify or guarantee ideality factor. This is normally not a problem since good-quality discrete transistors tend to have ideality factors that fall within a relatively narrow range. We have observed variations in remote temperature readings of less than $\pm 2^{\circ}\text{C}$ with a variety of discrete transistors. Still, it is good design practice to verify good consistency of temperature readings with several discrete transistors from any manufacturer under consideration.

Thermal Mass and Self-Heating

When sensing local temperature, these temperature sensors are intended to measure the temperature of the PC board to which they are soldered. The leads provide a good thermal path between the PC board traces and the die. As with all IC temperature sensors, thermal conductivity between the die and the ambient air is poor by comparison, making air temperature measurements impractical. Because the thermal mass of the PC board is far greater than that of the MAX6695/MAX6696, the device follows temperature changes on the PC board with little or no perceivable delay.

When measuring the temperature of a CPU or other IC with an on-chip sense junction, thermal mass has virtually no effect; the measured temperature of the junction tracks the actual temperature within a conversion cycle. When measuring temperature with discrete remote transistors, the best thermal response times are obtained with transistors in small packages (i.e., SOT23 or SC70). Take care to account for thermal gradients between the heat source and the sensor, and ensure

Table 1. Remote-Sensor Transistor Manufacturers

MANUFACTURER	MODEL NO.
Central Semiconductor (USA)	CMPT3904
Rohm Semiconductor (USA)	SST3904
Samsung (Korea)	KST3904-TF
Siemens (Germany)	SMBT3904
Zetex (England)	FMMT3904CT-ND

Note: Discrete transistors must be diode connected (base shorted to collector).

that stray air currents across the sensor package do not interfere with measurement accuracy.

Self-heating does not significantly affect measurement accuracy. Remote-sensor self-heating due to the diode current source is negligible. For local temperature measurements, the worst-case error occurs when autoconverting at the fastest rate and simultaneously sinking maximum current at the $\overline{\text{ALERT}}$ output. For example, with $V_{CC} = 3.6\text{V}$, a 4Hz conversion rate and $\overline{\text{ALERT}}$ sinking 1mA, the typical power dissipation is:

$$V_{CC} \times 500\mu\text{A} + 0.4\text{V} \times 1\text{mA} = 2.2\text{mW}$$

θ_{J-A} for the 16-pin QSOP package is about $+120^{\circ}\text{C/W}$, so assuming no copper PC board heat sinking, the resulting temperature rise is:

$$\Delta T = 2.2\text{mW} \times 120^{\circ}\text{C/W} = +0.264^{\circ}\text{C}$$

Even under these worst-case circumstances, it is difficult to introduce significant self-heating errors.

ADC Noise Filtering

The integrating ADC has good noise rejection for low-frequency signals such as power-supply hum. In environments with significant high-frequency EMI, connect an external 2200pF capacitor between DXP₋ and DXN. Larger capacitor values can be used for added filtering, but do not exceed 3300pF because it can introduce errors due to the rise time of the switched current source. High-frequency noise reduction is needed for high-accuracy remote measurements. Noise can be reduced with careful PC board layout as discussed in the *PC Board Layout* section.

Low-Power Standby Mode

Standby mode reduces the supply current to less than 10 μ A by disabling the ADC. Enter hardware standby (MAX6696 only) by forcing $\overline{\text{STBY}}$ low, or enter software standby by setting the $\overline{\text{RUN/STOP}}$ bit to 1 in the config-

Dual Remote/Local Temperature Sensors with SMBus Serial Interface

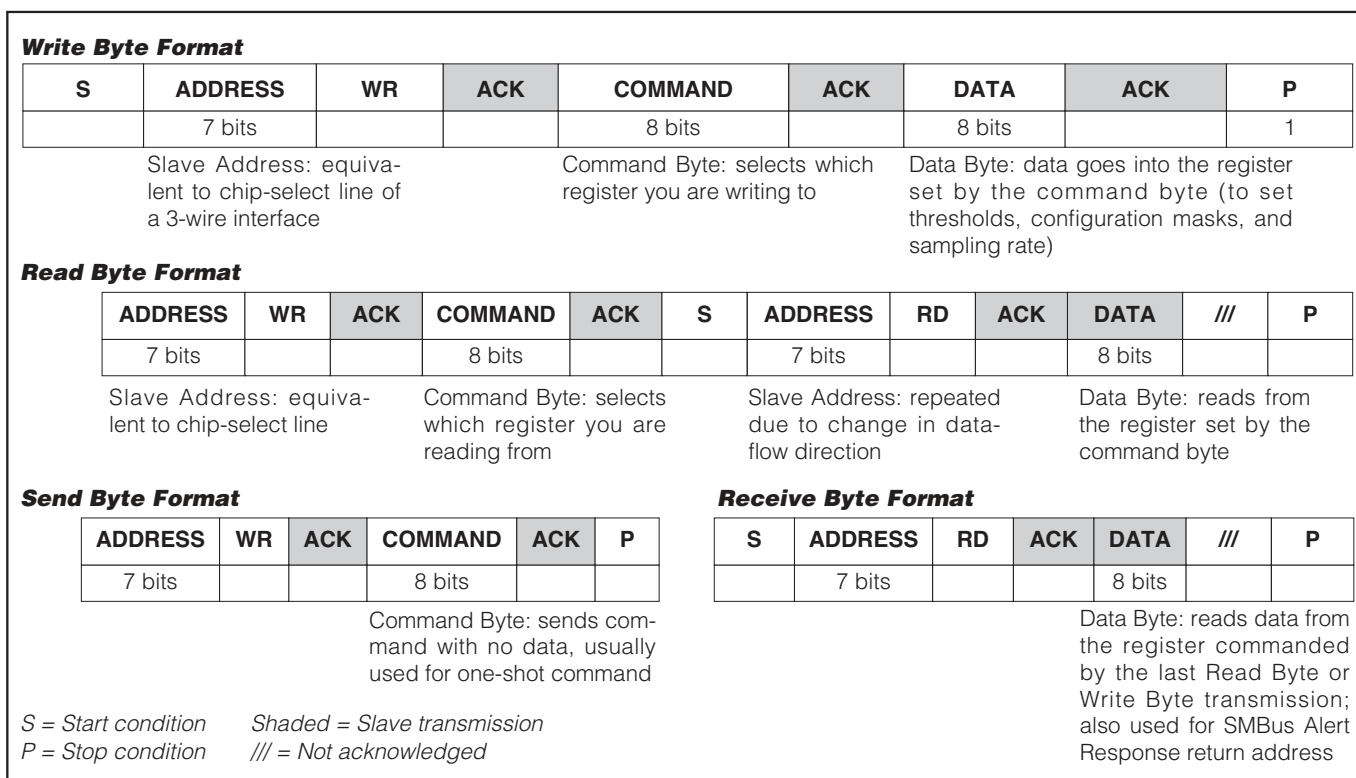

Figure 2. SMBus Protocols

uration byte register. Hardware and software standbys are very similar; all data is retained in memory, and the SMBus interface is alive and listening for SMBus commands but the SMBus timeout is disabled. The only difference is that in software standby mode, the one-shot command initiates a conversion. With hardware standby, the one-shot command is ignored. Activity on the SMBus causes the device to draw extra supply current.

Driving \overline{STBY} low overrides any software conversion command. If a hardware or software standby command is received while a conversion is in progress, the conversion cycle is interrupted, and the temperature registers are not updated. The previous data is not changed and remains available.

SMBus Digital Interface

From a software perspective, the MAX6695/MAX6696 appear as a series of 8-bit registers that contain temperature data, alarm threshold values, and control bits. A standard SMBus-compatible 2-wire serial interface is used to read temperature data and write control bits and alarm threshold data. The same SMBus slave address provides access to all functions.

The MAX6695/MAX6696 employ four standard SMBus protocols: Write Byte, Read Byte, Send Byte, and Receive Byte (Figure 2). The shorter Receive Byte protocol allows quicker transfers, provided that the correct data register was previously selected by a Read Byte instruction. Use caution with the shorter protocols in multimaster systems, since a second master could overwrite the command byte without informing the first master.

When the conversion rate control register is set $\geq 06h$, temperature data can be read from the read internal temperature (00h) and read external temperature (01h) registers. The temperature data format in these registers is 7 bits + sign in two's-complement form for each channel, with the LSB representing $+1^{\circ}C$ (Table 2). The MSB is transmitted first. Use bit 3 of the configuration register to select the registers corresponding to remote 1 or remote 2.

When the conversion rate control register is set $\leq 05h$, temperature data can be read from the read internal temperature (00h) and read external temperature (01h) registers, the same as for faster conversion rates. An additional 3 bits can be read from the read external extended temperature register (10h) and read internal

Dual Remote/Local Temperature Sensors with SMBus Serial Interface

extended temperature register (11h) (Table 3), which extends the temperature data to 10 bits + sign and the resolution to +0.125°C per LSB (Table 4).

When a conversion is complete, the main register and the extended register are updated almost simultaneously. Ensure that no conversions are completed between reading the main and extended registers so that when data that is read, both registers contain the result of the same conversion.

To ensure valid extended data, read extended resolution temperature data using one of the following approaches:

- Put the MAX6695/MAX6696 into standby mode by setting bit 6 of the configuration register to 1. Read the contents of the data registers. Return to run mode by setting bit 6 to zero.
- Put the MAX6695/MAX6696 into standby mode by setting bit 6 of the configuration register to 1. Initiate a one-shot conversion using Send Byte command 0Fh. When this conversion is complete, read the contents of the temperature data registers.

Diode Fault Alarm

There is a continuity fault detector at DXP_ that detects an open circuit between DXP_ and DXN, or a DXP_ short to V_{CC}, GND, or DXN. If an open or short circuit exists, the external temperature register (01h) is loaded with 1000 0000. Bit 2 (diode fault) of the status registers is correspondingly set to 1. The ALERT output asserts for open diode faults but not for shorted diode faults. Immediately after power-on reset (POR), the status register indicates that no fault is present until the end of the first conversion. After the conversion is complete, any diode fault is indicated in the appropriate status register. Reading the status register clears the diode fault bit in that register, and clears the ALERT output if set. If the diode fault is present after the next conversion, the status bit will again be set and the ALERT output will assert if the fault is an open diode fault.

Alarm Threshold Registers

Six registers, WLHO, WLLM, WRHA (1 and 2), and WRLN (1 and 2), store ALERT threshold values. WLHO and WLLM, are for **internal** ALERT high-temperature and low-temperature limits, respectively. Likewise, WRHA and WRLN are for **external** channel 1 and channel 2 high-temperature and low-temperature limits, respectively (Table 5). If either measured temperature equals or exceeds the corresponding ALERT threshold value, the ALERT output is asserted. The POR state of both internal and external ALERT high-temperature limit registers is 0100 0110 or +70°C.

Table 2. Data Format (Two's Complement)

TEMP (°C)	DIGITAL OUTPUT
+130.00	0 111 1111
+127.00	0 111 1111
+126.00	0 111 1110
+25.25	0 001 1001
+0.50	0 000 0001
0	0 000 0000
-1	1 111 1111
-55	1 100 1001
Diode fault (short or open)	1 000 0000

Table 3. Extended Resolution Register

FRACTIONAL TEMPERATURE (°C)	CONTENTS OF EXTENDED REGISTER
0	000X XXXX
+0.125	001X XXXX
+0.250	010X XXXX
+0.375	011X XXXX
+0.500	100X XXXX
+0.625	101X XXXX
+0.750	110X XXXX
+0.875	111X XXXX

Note: Extended resolution applies only for conversion rate control register values of 05h or less.

Table 4. Data Format in Extended Mode

TEMP (°C)	INTEGER TEMP	FRACTIONAL TEMP
+130.00	0 111 1111	000X XXXX
+127.00	0 111 1111	000X XXXX
+126.5	0 111 1110	100X XXXX
+25.25	0 001 1001	010X XXXX
+0.50	0 000 0000	100X XXXX
0	0 000 0000	000X XXXX
-1	1 111 1111	000X XXXX
-1.25	1111 1111	010X XXXX
-55	1100 1001	000X XXXX

Dual Remote/Local Temperature Sensors with SMBus Serial Interface

MAX6695/MAX6696

Table 5. Command-Byte Register Bit Assignments

REGISTER	ADDRESS	POR STATE	FUNCTION
RLTS	00 h	0000 0000 (0°C)	Read internal temperature
RRTE	01 h	0000 0000 (0°C)	Read external channel 1 temperature if bit 3 of configuration register is 0 ; Read external channel 2 temperature if bit 3 of configuration register is 1
RSL1	02 h	1000 0000	Read status register 1
RCL	03 h	0000 0000	Read configuration byte (fault queue should be disabled at startup)
RCRA	04 h	0000 0110	Read conversion rate byte
RLHN	05 h	0100 0110 (+70°C)	Read internal $\overline{\text{ALERT}}$ high limit
RLLI	06 h	1100 1001 (-55°C)	Read internal $\overline{\text{ALERT}}$ low limit
RRHI	07 h	0100 0110 (+70°C)	Read external channel 1 $\overline{\text{ALERT}}$ high limit if bit 3 of configuration register is 0 ; Read external channel 2 $\overline{\text{ALERT}}$ high limit if bit 3 of configuration register is 1
RRLS	08 h	1100 1001 (-55°C)	Read external channel 1 $\overline{\text{ALERT}}$ low limit if bit 3 of configuration register is 0 ; Read external channel 2 $\overline{\text{ALERT}}$ low limit if bit 3 of configuration register is 1
WCA	09 h	0010 0000	Write configuration byte
WCRW	0A h	0000 0110	Write conversion rate byte
WLHO	0B h	0100 0110 (+70°C)	Write internal $\overline{\text{ALERT}}$ high limit
WLLM	0C h	1100 1001 (-55°C)	Write internal $\overline{\text{ALERT}}$ low limit
WRHA	0D h	0100 0110 (+70°C)	Write external channel 1 $\overline{\text{ALERT}}$ high limit if bit 3 of configuration register is 0 ; Write external channel 2 $\overline{\text{ALERT}}$ high limit if bit 3 of configuration register is 1
WRLN	0E h	1100 1001 (-55°C)	Write external channel 1 $\overline{\text{ALERT}}$ low limit if bit 3 of configuration register is 0 ; Write external channel 2 $\overline{\text{ALERT}}$ low limit if bit 3 of configuration register is 1
OSHT	0F h	0000 0000	One shot
REET	10 h	0000 0000	Read extended temp of external channel 1 if bit 3 of configuration register is 0 ; Read extended temp of external channel 2 if bit 3 of configuration register is 1
RIET	11 h	0000 0000	Read internal extended temperature
RSL2	12 h	0000 0000	Read status register 2
RWO2E	16 h	0111 1000 (+120°C)	Read/write external $\overline{\text{OT2}}$ limit for channel 1 if bit 3 of configuration register is 0 ; Read/write external $\overline{\text{OT2}}$ limit for channel 2 if bit 3 of configuration register is 1
RWO2I	17 h	0101 1010 (+90°C)	Read/write internal $\overline{\text{OT2}}$ limit
RWO1E	19 h	0101 1010 (+90°C)	Read/write external $\overline{\text{OT1}}$ limit for channel 1 if bit 3 of configuration register is 0 ; Read/write external $\overline{\text{OT1}}$ limit for channel 2 if bit 3 of configuration register is 1
RWO1I	20 h	0100 0110 (+70°C)	Read/write internal $\overline{\text{OT1}}$ limit

Dual Remote/Local Temperature Sensors with SMBus Serial Interface

Table 5. Command-Byte Register Bit Assignments (continued)

REGISTER	ADDRESS	POR STATE	FUNCTION
HYST	21 h	0000 1010 (10°C)	Temperature hysteresis for $\overline{OT1}$ and $\overline{OT2}$
RDID	FE h	4D h	Read manufacturer ID

The POR state of both internal and external \overline{ALERT} low-temperature limit registers is 1100 1001 or -55°C. Use bit 3 of the configuration register to select remote 1 or remote 2 when reading or writing remote thresholds.

Additional registers, RWO1E, RWO1I, RWO2E, and RWO2I, store remote and local alarm threshold data information corresponding to the $\overline{OT1}$ and $\overline{OT2}$ outputs (See the *$\overline{OT1}$ and $\overline{OT2}$ Overtemperature Alarms* section.)

\overline{ALERT} Interrupt Mode

An \overline{ALERT} interrupt occurs when the internal or external temperature reading exceeds a high- or low-temperature limit (both limits are user programmable), or when the remote diode is disconnected (for continuity fault detection). The \overline{ALERT} interrupt output signal is latched and can be cleared only by reading either of the status registers or by successfully responding to an Alert Response address. In both cases, the alert is cleared but is reasserted at the end of the next conversion if the fault condition still exists. The interrupt does not halt automatic conversions. The interrupt output pin is open drain so that multiple devices can share a common interrupt line. The interrupt rate never exceeds the conversion rate.

Alert Response Address

The SMBus Alert Response interrupt pointer provides quick fault identification for simple slave devices. Upon receiving an interrupt signal, the host master can broadcast a Receive Byte transmission to the Alert Response slave address (see *Slave Addresses* section). Then, any slave device that generated an interrupt attempts to identify itself by putting its own address on the bus.

The Alert Response can activate several different slave devices simultaneously, similar to the I²C General Call. If more than one slave attempts to respond, bus arbitration rules apply, and the device with the lower address code wins. The losing device does not generate an acknowledgement and continues to hold the \overline{ALERT} line low until cleared. (The conditions for clearing an alert vary depending on the type of slave device.) Successful completion of the Alert Response protocol clears the interrupt latch, provided the condition that caused the alert no longer exists. If the condition still

exists, the device reasserts the \overline{ALERT} interrupt at the end of the next conversion.

$\overline{OT1}$ and $\overline{OT2}$ Overtemperature Alarms

Two registers, RWO1E and RWO1I, store remote and local alarm threshold data corresponding to the $\overline{OT1}$ output. Two other registers, RWO2E and RWO2I, store remote and local alarm threshold data corresponding to the $\overline{OT2}$ output. The values stored in these registers are high-temperature thresholds. The $\overline{OT1}$ or $\overline{OT2}$ output is asserted if any one of the measured temperatures equals or exceeds the corresponding alarm threshold value.

$\overline{OT1}$ and $\overline{OT2}$ always operate in comparator mode and are asserted when the temperature rises above a value programmed in the appropriate threshold register. They are deasserted when the temperature drops below this threshold, minus the programmed value in the hysteresis HYST register (21h). An overtemperature output can be used to activate a cooling fan, send a warning, initiate clock throttling, or trigger a system shutdown to prevent component damage. The HYST byte sets the amount of hysteresis to deassert both $\overline{OT1}$ and $\overline{OT2}$ outputs. The data format for the HYST byte is 7 bit + sign with +1°C resolution. Bit 7 of the HYST register should always be zero.

$\overline{OT1}$ responds immediately to temperature faults. $\overline{OT2}$ activates either immediately or after four consecutive remote channel temperature faults, depending on the state of the fault queue bit (bit 5 of the configuration register).

Command Byte Functions

The 8-bit command byte register (Table 5) is the master index that points to the various other registers within the MAX6695/MAX6696. This register's POR state is 0000 0000, so a Receive Byte transmission (a protocol that lacks the command byte) occurring immediately after POR returns the current local temperature data.

One-Shot

The one-shot command immediately forces a new conversion cycle to begin. If the one-shot command is received when the MAX6695/MAX6696 are in software standby mode ($\overline{RUN/STOP}$ bit = 1), a new conversion is

Dual Remote/Local Temperature Sensors with SMBus Serial Interface

Table 6. Configuration Byte Functions

BIT	NAME	POR STATE	FUNCTION
7(MSB)	MASK1	0	Mask $\overline{\text{ALERT}}$ interrupts when 1.
6	$\overline{\text{RUN/STOP}}$	0	Standby mode control bit. If 1, immediately stops converting and enters standby mode. If zero, it converts in either one-shot or timer mode.
5	Fault Queue	0	Fault queue enables when 1. When set to 1, four consecutive faults must occur before $\overline{\text{OT2}}$ output is asserted.
4	RFU	0	Reserved.
3	Remote 2 Select	0	0: Read/write remote 1 temperature and set-point values. 1: Read/write remote 2 temperature and set-point values.
2	SMB Timeout Disable	0	When set to 1, it disables the SMBus timeout, as well as the alert response.
1	MASK $\overline{\text{ALERT}}$ Channel 2	0	When set to 1, it masks $\overline{\text{ALERT}}$ interrupt due to channel 2.
0	MASK $\overline{\text{ALERT}}$ Channel 1	0	When set to 1, it masks $\overline{\text{ALERT}}$ interrupt due to channel 1.

begun, after which the device returns to standby mode. If a conversion is in progress when a one-shot command is received, the command is ignored. If a one-shot command is received in autoconvert mode ($\overline{\text{RUN/STOP}}$ bit = 0) between conversions, a new conversion begins, the conversion rate timer is reset, and the next automatic conversion takes place after a full delay elapses.

Fault Queue Function

To avoid false triggering of the MAX6695/MAX6696 in noisy environments, a fault queue is provided, which can be enabled by setting bit 5 (configuration register) to 1. Four channel 1 fault or two channel 2 fault events must occur consecutively before the fault output ($\overline{\text{OT2}}$) becomes active. Any reading that breaks the sequence resets the fault queue counter. If there are three over-limit readings followed by a within-limit reading, the remote channel 1 fault queue counter is reset.

Configuration Byte Functions

The configuration byte register (Table 6) is a read-write register with several functions. Bit 7 is used to mask (disable) $\overline{\text{ALERT}}$ interrupts. Bit 6 puts the device into software standby mode (STOP) or autonomous (RUN) mode. Bit 5, when 1, enables the Fault Queue. Bit 4 is reserved. Bit 3 is used to select either remote channel 1 or remote channel 2 for reading temperature data or for setting or reading temperature limits. Bit 2 disables the SMBus timeout, as well as the Alert Response. Bit 1 masks $\overline{\text{ALERT}}$ interrupt due to channel 2 when high. Bit 0 masks $\overline{\text{ALERT}}$ interrupt due to channel 1 when high.

Status Byte Functions

The status registers (Tables 7 and 8) indicate which (if any) temperature thresholds have been exceeded and if there is an open-circuit fault detected with the external sense junctions. Status register 1 also indicates whether the ADC is converting. After POR, the normal state of the registers' bits is zero (except bit 7 of status register 1), assuming no alert or overtemperature conditions are present. Bits 0 through 6 of status register 1 and bits 1 through 7 of status register 2 are cleared by any successful read of the status registers, unless the fault persists. The $\overline{\text{ALERT}}$ output follows the status flag bit. Both are cleared when successfully read, but if the condition still exists, they reassert at the end of the next conversion.

The bits indicating $\overline{\text{OT1}}$ and $\overline{\text{OT2}}$ are cleared only on reading status even if the fault conditions still exist. Reading the status byte does not clear the $\overline{\text{OT1}}$ and $\overline{\text{OT2}}$ outputs. One way to eliminate the fault condition is for the measured temperature to drop below the temperature threshold minus the hysteresis value. Another way to eliminate the fault condition is by writing new values for the RWO2E, RWO2I, RWO1E, RWO1I, or HYST registers so that a fault condition is no longer present.

When autoconverting, if the T_{HIGH} and T_{LOW} limits are close together, it is possible for both high-temp and low-temp status bits to be set, depending on the amount of time between Status Read operations. In these circumstances, it is best not to rely on the status bits to indicate reversals in long-term temperature changes. Instead, use a current temperature reading to establish the trend direction.

Dual Remote/Local Temperature Sensors with SMBus Serial Interface

Table 7. Status Register 1 Bit Assignments

BIT	NAME	POR	FUNCTION
7(MSB)	BUSY	1	A/D is busy converting when 1.
6	LHIGH	0	When 1, internal high-temperature ALERT has tripped, cleared by POR or by reading this status register. If the fault condition still exists, this bit is set again after the next conversion.
5	LLOW	0	When 1, internal low-temperature ALERT has tripped, cleared by POR or by reading this status register. If the fault condition still exists, this bit is set again after the next conversion.
4	R1HIGH	0	A 1 indicates external junction 1 high-temperature ALERT has tripped, cleared by POR or by reading this status register. If the fault condition still exists, this bit is set again after the next conversion.
3	R1LOW	0	A 1 indicates external junction 1 low-temperature ALERT has tripped, cleared by POR or by reading this status register. If the fault condition still exists, this bit is set again after the next conversion.
2	1OPEN	0	A 1 indicates external diode 1 is open, cleared by POR or by reading this status register. If the fault condition still exists, this bit is set again after the next conversion.
1	R1OT1	0	A 1 indicates external junction 1 temperature exceeds the OT1 threshold, cleared by reading this register.
0	IOT1	0	A 1 indicates internal junction temperature exceeds the internal OT1 threshold, cleared by reading this register.

Table 8. Status Register 2 Bit Assignments

BIT	NAME	POR	FUNCTION
7(MSB)	IOT2	0	A 1 indicates internal junction temperature exceeds the internal OT2 threshold, cleared by reading this register.
6	R2OT2	0	A 1 indicates external junction temperature 2 exceeds the external OT2 threshold, cleared by reading this register.
5	R1OT2	0	A 1 indicates external junction temperature 1 exceeds the OT2 threshold, cleared by reading this register.
4	R2HIGH	0	A 1 indicates external junction 2 high-temperature ALERT has tripped; cleared by POR or readout of the status register. If the fault condition still exists, this bit is set again after the next conversion.
3	R2LOW	0	A 1 indicates external junction 2 low-temperature ALERT has tripped; cleared by POR or readout of the status register. If the fault condition still exists, this bit is set again after the next conversion.
2	2OPEN	0	A 1 indicates external diode 2 open; cleared by POR or readout of the status register. If the fault condition still exists, this bit is set again after the next conversion.
1	R2OT1	0	A 1 indicates external junction 2 temperature exceeds the OT1 threshold, cleared by reading this register.
0	RFU	0	Reserved.

Reset (MAX6696 Only)

The MAX6696's registers are reset to their power-on values if RESET is driven high. When reset occurs, all registers go to their default values, and the SMBus address pins are sampled.

Conversion Rate Byte

The conversion-rate control register (Table 9) programs the time interval between conversions in free-running autonomous mode (RUN/STOP = 0). This variable rate control can be used to reduce the supply current in portable-equipment applications. The conversion rate

Dual Remote/Local Temperature Sensors with SMBus Serial Interface

Table 9. Conversion-Rate Control Register (POR = 0110)

BIT 3	BIT 1	BIT 0	HEX	CONVERSION RATE (Hz) REMOTE CHANNEL 2 AND LOCAL	CONVERSION RATE (Hz) REMOTE CHANNEL 1	CONVERSION PERIOD (s) REMOTE CHANNEL 2 AND LOCAL	CONVERSION PERIOD (s) REMOTE CHANNEL 1
0	0	0	00h	0.0625	0.125	16	8
0	0	1	01h	0.125	0.25	8	4
0	1	0	02h	0.25	0.5	4	2
0	1	1	03h	0.5	1	2	1
1	0	0	04h	1	2	1	0.5
1	0	1	05h	2	4	0.5	0.25
1	1	0	06h	4	8	0.25	0.125
1	1	1	07h	4	8	0.25	0.125

Note: Extended resolution applies only for conversion rate control register values of 05h or less.

byte's POR state is 06h (4Hz). The MAX6695/MAX6696 use only the 3 LSBs of the control register. The 5 MSBs are don't care and should be set to zero. The conversion rate tolerance is $\pm 25\%$ at any rate setting.

Valid A/D conversion results for all channels are available one total conversion time after initiating a conversion, whether conversion is initiated through the RUN/STOP bit, hardware STBY pin, one-shot command, or initial power-up.

Slave Addresses

The MAX6695 has a fixed address of 0011 000. The MAX6696 device address can be set to any one of nine different values at power-up by pin strapping ADD0 and ADD1 so that more than one MAX6695/MAX6696 can reside on the same bus without address conflicts (Table 10).

The address pin states are checked at POR and RESET only, and the address data stays latched to reduce quiescent supply current due to the bias current needed for high-impedance state detection. The MAX6695/MAX6696 also respond to the SMBus Alert Response slave address (see the *Alert Response Address* section).

POR and UVLO

To prevent unreliable power-supply conditions from corrupting the data in memory and causing erratic behavior, a POR voltage detector monitors V_{CC} and clears the memory if V_{CC} falls below 1.45V (typ; see *Electrical Characteristics*). When power is first applied and V_{CC} rises above 2.0V (typ), the logic blocks begin operating, although reads and writes at V_{CC} levels below 3.0V are not recommended.

Table 10. POR Slave Address Decoding (ADD0 and ADD1)

ADD0	ADD1	ADDRESS
GND	GND	0011 000
GND	High-Z	0011 001
GND	V _{CC}	0011 010
High-Z	GND	0101 001
High-Z	High-Z	0101 010
High-Z	V _{CC}	0101 011
V _{CC}	GND	1001 100
V _{CC}	High-Z	1001 101
V _{CC}	V _{CC}	1001 110

Power-Up Defaults

- Interrupt latch is cleared.
- Address select pin is sampled.
- ADC begins autoconverting at a 4Hz rate for channel 2/local and 8Hz for channel 1.
- Command register is set to 00h to facilitate quick internal Receive Byte queries.
- THIGH and TLOW registers are set to default max and min limits, respectively.
- Hysteresis is set to 10°C.

Dual Remote/Local Temperature Sensors with SMBus Serial Interface

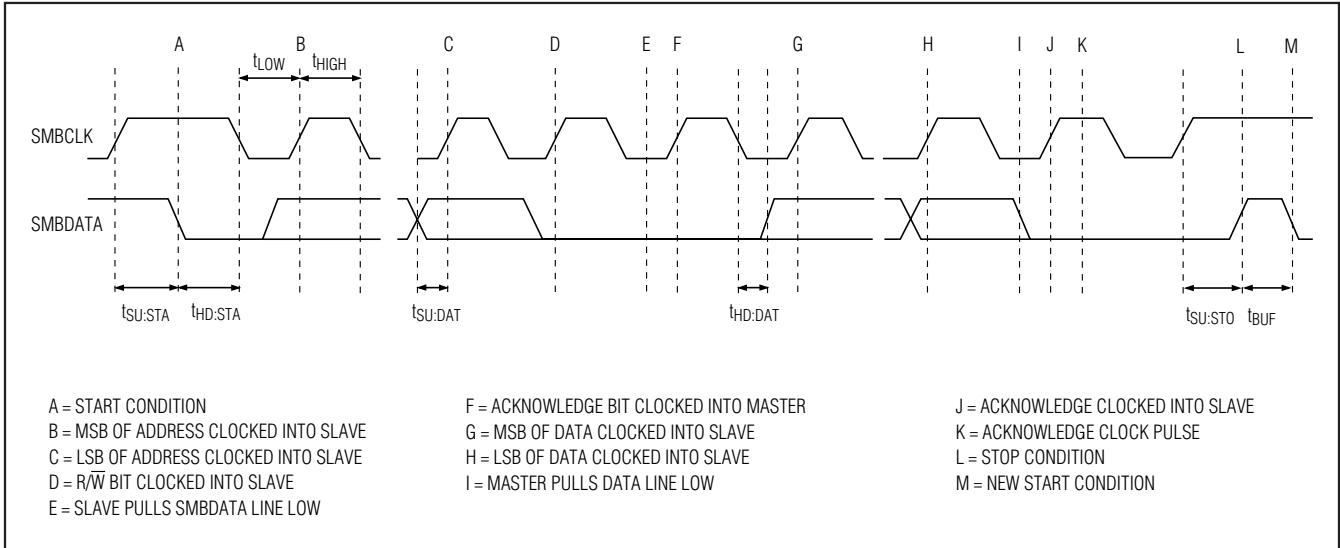

Figure 3. SMBus Write Timing Diagram

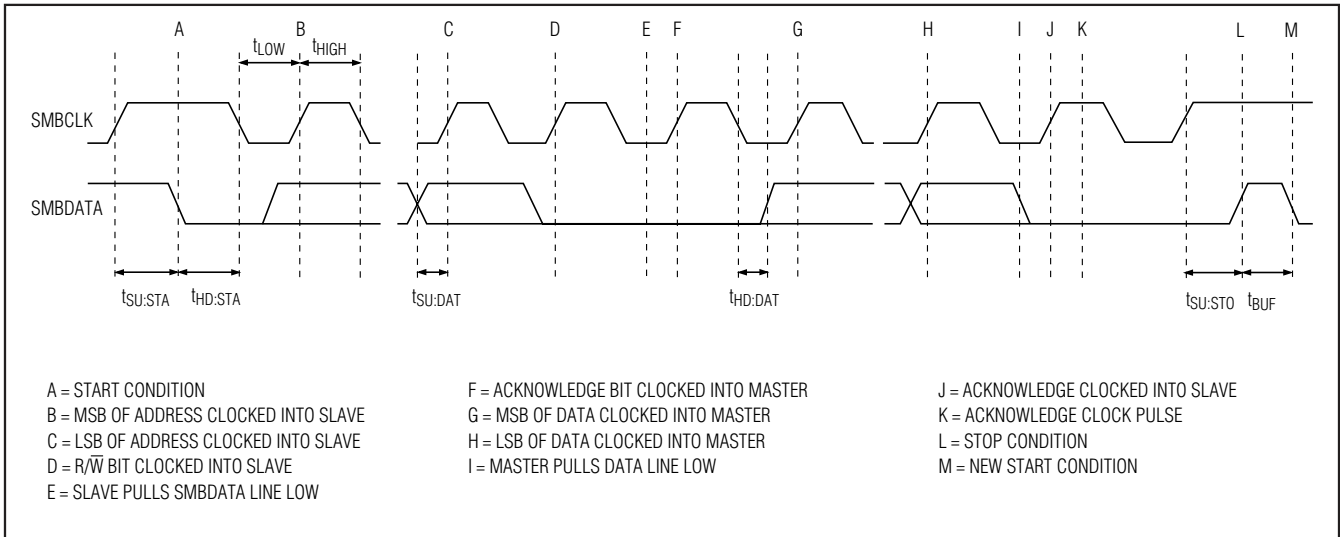

Figure 4. SMBus Read Timing Diagram

PC Board Layout

Follow these guidelines to reduce the measurement error when measuring remote temperature:

- 1) Place the MAX6695/MAX6696 as close as is practical to the remote diode. In noisy environments, such as a computer motherboard, this distance can be 4in to 8in (typ). This length can be increased if the worst noise sources are avoided. Noise sources include CRTs, clock generators, memory buses, and PCI buses.

- 2) Do not route the DXP-DXN lines next to the deflection coils of a CRT. Also, do not route the traces across fast digital signals, which can easily introduce +30°C error, even with good filtering.
- 3) Route the DXP and DXN traces in parallel and in close proximity to each other. Each parallel pair of traces (DXP1 and DXN or DXP2 and DXN) should go to a remote diode. Connect the two DXN traces at the MAX6695/MAX6696. Route these traces away from any higher voltage traces, such as +12VDC.

Dual Remote/Local Temperature Sensors with SMBus Serial Interface

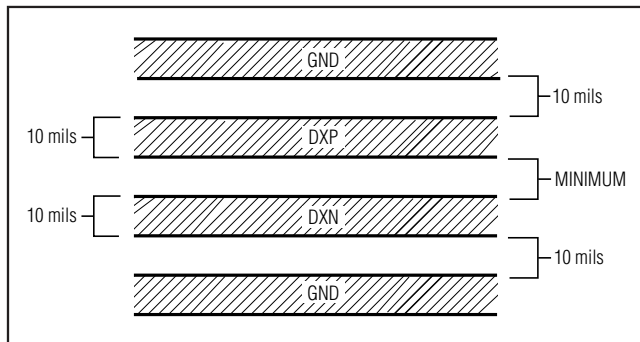

Figure 5. Recommended DXP-DXN PC Traces

Leakage currents from PC board contamination must be dealt with carefully since a $20M\Omega$ leakage path from DXP to ground causes about $+1^{\circ}C$ error. If high-voltage traces are unavoidable, connect guard traces to GND on either side of the DXP-DXN traces (Figure 5).

- 4) Route through as few vias and crossunders as possible to minimize copper/solder thermocouple effects.
- 5) Use wide traces when practical.
- 6) When the power supply is noisy, add a resistor (up to 47Ω) in series with V_{CC} (see *Typical Operating Circuit*).

Twisted-Pair and Shielded Cables

Use a twisted-pair cable to connect the remote sensor for remote-sensor distances longer than 8in or in very noisy environments. Twisted-pair cable lengths can be between 6ft and 12ft before noise introduces excessive errors. For longer distances, the best solution is a shielded twisted pair like that used for audio microphones. For example, Belden #8451 works well for distances up to 100ft in a noisy environment. At the device, connect the twisted pair to DXP and DXN and the shield to GND. Leave the shield unconnected at the remote sensor.

For very long cable runs, the cable's parasitic capacitance often provides noise filtering, so the $2200pF$ capacitor can often be removed or reduced in value. Cable resistance also affects remote-sensor accuracy. For every 1Ω of series resistance the error is approximately $+1/2^{\circ}C$.

Chip Information

PROCESS: BiCMOS

Typical Operating Circuits (continued)

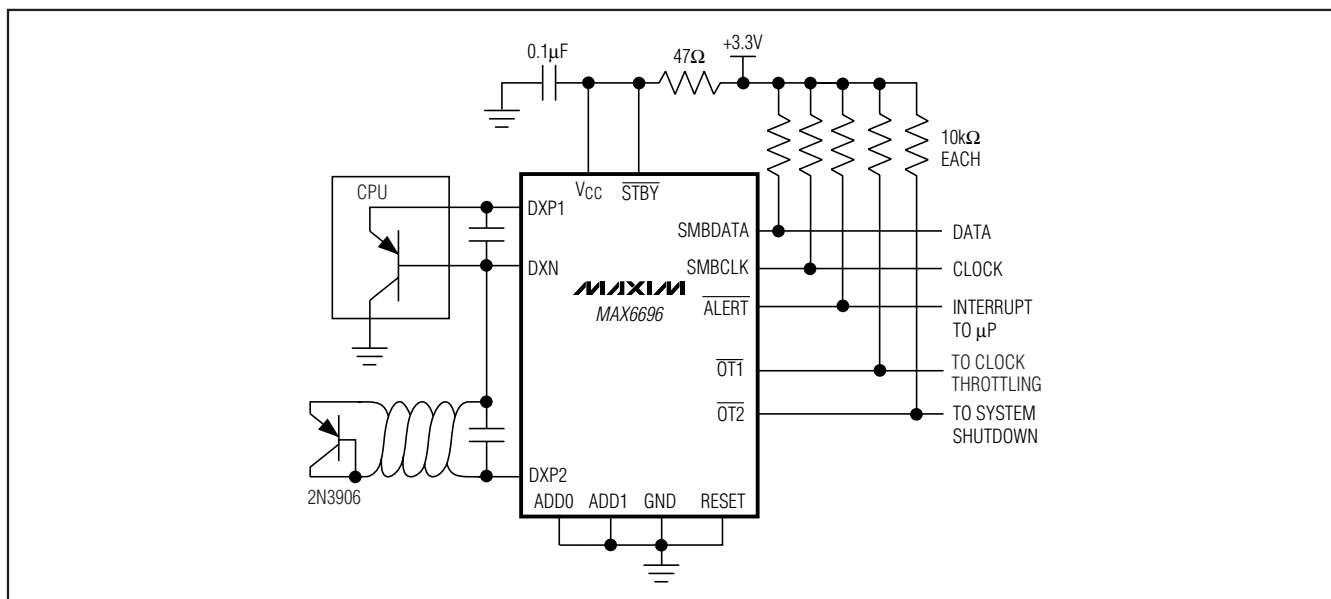

Dual Remote/Local Temperature Sensors with SMBus Serial Interface

Pin Configurations

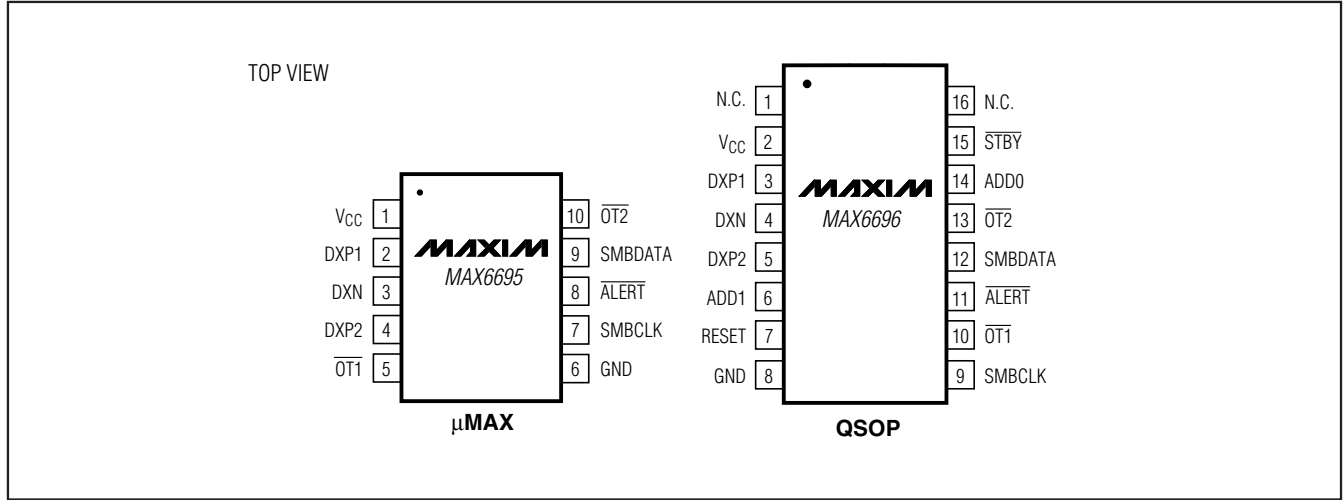

Package Information

For the latest package outline information and land patterns (footprints), go to www.maxim-ic.com/packages. Note that a "+", "#", or "-" in the package code indicates RoHS status only. Package drawings may show a different suffix character, but the drawing pertains to the package regardless of RoHS status.

PACKAGE TYPE	PACKAGE CODE	OUTLINE NO.	LAND PATTERN NO.
10 µMAX	U10CN+1	21-0061	90-0330
16 QSOP	E16+1	21-0055	90-0167

Dual Remote/Local Temperature Sensors with SMBus Serial Interface

Revision History

REVISION NUMBER	REVISION DATE	DESCRIPTION	PAGES CHANGED
0	2/04	Initial release	—
1	5/04	Removed future status from MAX6696 in the <i>Ordering Information</i> table; updated the <i>OT1 and OT2 Overtemperature Alarms</i> section	1, 12
2	11/05	Updated the <i>Features</i> section, <i>Ordering Information</i> table, <i>Electrical Characteristics</i> table, and <i>Effect of Ideality Factor</i> section	1, 2, 6
3	4/11	Added lead(Pb)-free and tape-and-reel options to the <i>Ordering Information</i> table; added soldering information to the <i>Absolute Maximum Ratings</i> section; corrected the units for data setup time and data hold time from μs to ns in the <i>Electrical Characteristics</i> table; added the <i>Package Information</i> table	1, 2, 3, 18

MAX6695/MAX6696

Maxim cannot assume responsibility for use of any circuitry other than circuitry entirely embodied in a Maxim product. No circuit patent licenses are implied. Maxim reserves the right to change the circuitry and specifications without notice at any time.

Maxim Integrated Products, 120 San Gabriel Drive, Sunnyvale, CA 94086 408-737-7600 _____ 19