

FEATURES

- **Guaranteed AC performance over temperature and voltage:**
 - DC to 10.7Gbps data throughput
 - DC to > 7GHz f_{MAX} (clock)
 - < 240ps propagation delay
 - < 70ps t_r / t_f times
- **Ultra-low crosstalk-induced jitter: 0.7ps_{RMS}**
- **Ultra-low jitter design:**
 - < 1ps_{RMS} random jitter
 - < 10ps_{PP} deterministic jitter
 - < 10ps_{PP} total jitter (clock)
- **Unique input termination and V_T pin accepts DC-coupled and AC-coupled inputs (CML, PECL, LVDS)**
- **400mV (100k) LVPECL output swing**
- **Power supply 2.5V ±5% or 3.3V ±10%**
- **−40°C to +85°C temperature range**
- **Available in 16-pin (3mm × 3mm) MLF® package**

APPLICATIONS

- **Redundant clock distribution**
- **OC-3 to OC-192 SONET/SDH clock/data distribution**
- **Loopback**
- **Fibre Channel distribution**

FUNCTIONAL BLOCK DIAGRAM

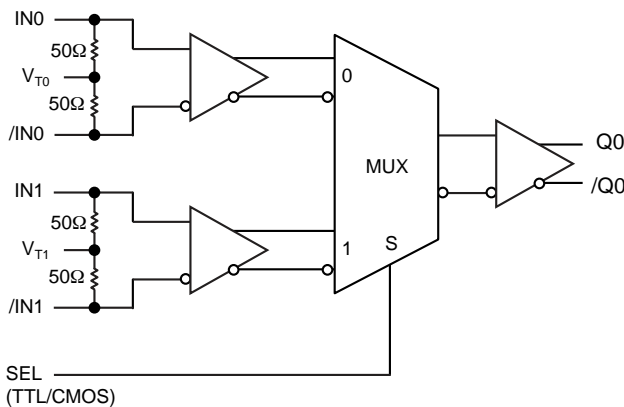

DESCRIPTION

The SY58019U is a 2.5V/3.3V precision, high-speed, 2:1 differential MUX capable of handling clocks up to 7GHz and data up to 10.7Gbps.

The differential input includes Micrel's unique, 3-pin input termination architecture that allows customers to interface to any differential signal (AC- or DC-coupled) as small as 100mV without any level shifting or termination resistor networks in the signal path. The outputs are 400mV, 100k compatible, LVPECL, with extremely fast rise/fall times guaranteed to be less than 70ps.

The SY58019U operates from a 2.5V ±5% supply or a 3.3V ±10% supply and is guaranteed over the full industrial temperature range of −40°C to +85°C. For applications that require CML outputs, consider the SY58017U or for 800mV LVPECL outputs the SY58018U. The SY58019U is part of Micrel's high-speed, Precision Edge® product line.

All support documentation can be found on Micrel's web site at www.micrel.com.

TYPICAL PERFORMANCE

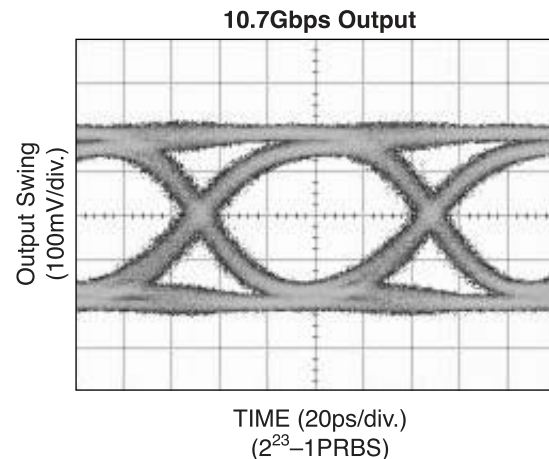

PACKAGE ORDERING INFORMATION

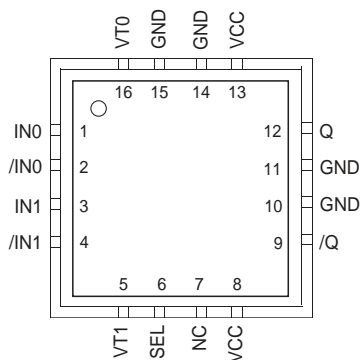

16-Pin MLF®

Ordering Information⁽¹⁾

Part Number	Package Type	Operating Range	Package Marking	Lead Finish
SY58019UMI	MLF-16	Industrial	019U	Sn-Pb
SY58019UMITR ⁽²⁾	MLF-16	Industrial	019U	Sn-Pb
SY58019UMG ⁽³⁾	MLF-16	Industrial	019U with Pb-Free bar-line indicator	Pb-Free NiPdAu
SY58019UMGTR ^(2, 3)	MLF-16	Industrial	019U with Pb-Free bar-line indicator	Pb-Free NiPdAu

Notes:

1. Contact factory for die availability. Dice are guaranteed at $T_A = 25^\circ\text{C}$, DC electricals only.
2. Tape and Reel.
3. Pb-Free package recommended for new designs.

PIN DESCRIPTION

Pin Number	Pin Name	Pin Function
1, 2 3, 4	IN0, /INO IN1, /IN1	Differential Input: These input pairs are the differential signal inputs to the device. They accept differential AC- or DC-coupled signals as small as 100mV. Each pin of a pair internally terminates to a V_T pin through 50Ω . Note that these inputs will default to an indeterminate state if left open. Please refer to the "Input Interface Applications" section for more details.
16, 5	VT0, VT1	Input Termination Center-Tap: Each side of the differential input pair terminates to a V_T pin. The V_{T0} and V_{T1} pins provide a center-tap to a termination network for maximum interface flexibility. See "Input Interface Applications" section for more details.
6	SEL	This single-ended TTL/CMOS compatible input selects the inputs to the multiplexer. Note that this input is internally connected to a $25k\Omega$ pull-up resistor and will default to a logic HIGH state if left open.
7	NC	No connect.
8, 13	VCC	Positive Power Supply: Bypass with $0.1\mu\text{F} \parallel 0.01\mu\text{F}$ low ESR capacitors. $0.01\mu\text{F}$ capacitor should be as close to V_{CC} pin as possible.
12, 9	Q, /Q	Differential Outputs: This 100k compatible LVPECL output pair is the output of the device. Terminate through 50Ω to $V_{CC} - 2V$. See "Output Interface Applications" section. It is a logic function of the IN0, IN1, and SEL inputs. Please refer to the "Truth Table" for details.
10, 11, 14, 15	GND, Exposed Pad	Ground. Ground pins and exposed pad must be connected to the same ground plane.

TRUTH TABLE

SEL	Output
0	CH0 Input Selected
1	CH1 Input Selected

Absolute Maximum Ratings(1)

Power Supply Voltage (V_{CC}) -0.5V to +4.0V
 Input Voltage (V_{IN}) -0.5V to V_{CC}
 LVPECL Output Current (I_{OUT})
 Continuous 50mA
 Surge 100mA
 Termination Current(3)
 Source or Sink Current on V_T pin ± 100 mA
 Input Current
 Source or Sink Current on IN, /IN pin ± 50 mA
 Lead Temperature (soldering, 20 sec.) 260°C
 Storage Temperature Range (T_S) -65°C to +150°C

Operating Ratings(2)

Power Supply Voltage (V_{CC}) +2.375V to +2.625V
 +3.0V to +3.6V
 Ambient Temperature Range (T_A) -40°C to +85°C
 Package Thermal Resistance(4)
 MLF® (θ_{JA})
 Still-Air 60°C/W
 MLF® (ψ_{JB})
 Junction-to-Board 38°C/W

DC ELECTRICAL CHARACTERISTICS(5)

$T_A = -40^\circ\text{C}$ to $+85^\circ\text{C}$, unless otherwise stated.

Symbol	Parameter	Condition	Min	Typ	Max	Units
V_{CC}	Power Supply Voltage	$V_{CC} = 2.5\text{V}$ $V_{CC} = 3.3\text{V}$	2.375 3.0	2.5 3.3	2.625 3.6	V
I_{CC}	Power Supply Current	No load, max. V_{CC}		55	70	mA
R_{DIFF_IN}	Differential Input Resistance (IN0-to-/IN0, IN1-to-/IN1)		80	100	120	Ω
R_{IN}	Input Resistance (IN0-to- V_{T0} , /IN0-to- V_{T0} , IN1-to- V_{T1} , /IN1-to- V_{T1})		40	50	60	Ω
V_{IH}	Input HIGH Voltage (IN0, /IN0, IN1, /IN1)	Note 6	$V_{CC} - 1.6$		V_{CC}	V
V_{IL}	Input LOW Voltage (IN0, /IN0, IN1, /IN1)		0		$V_{IH} - 0.1$	V
V_{IN}	Input Voltage Swing (IN0, /IN0, IN1, /IN1)	See Figure 1a	0.1		1.7	V
V_{DIFF_IN}	Differential Input Voltage Swing IN0, /IN0 , IN1, /IN1	See Figure 1b	0.2			V
$V_{T\ IN}$	IN to V_T (IN0, /IN0, IN1, /IN1)				1.28	V

Notes:

1. Permanent device damage may occur if "Absolute Maximum Ratings" are exceeded. This is a stress rating only and functional operation is not implied at conditions other than those detailed in the operational sections of this data sheet. Exposure to "Absolute Maximum Ratings" conditions for extended periods may affect device reliability.
2. The data sheet limits are not guaranteed if the device is operated beyond the operating ratings.
3. Due to the limited drive capability, use for input of the same package only.
4. Package thermal resistance assumes exposed pad is soldered (or equivalent) to the device's most negative potential (GND) on the PCB. ψ_{JB} uses 4-layer θ_{JA} in still-air measurement, unless otherwise stated.
5. The circuit is designed to meet the DC specifications shown in the above table after thermal equilibrium has been established.
6. V_{IH} (min) not lower than 1.2V.

LVPECL OUTPUT DC ELECTRICAL CHARACTERISTICS⁷⁾

$V_{CC} = 2.5V \pm 5\%$ or $3.3V \pm 10\%$; $T_A = -40^\circ C$ to $+85^\circ C$; $R_L = 50\Omega$ to $V_{CC} - 2V$, unless otherwise stated.

Symbol	Parameter	Condition	Min	Typ	Max	Units
V_{OH}	Output HIGH Voltage Q, /Q		$V_{CC} - 1.145$		$V_{CC} - 0.895$	V
V_{OL}	Output LOW Voltage Q, /Q		$V_{CC} - 1.545$		$V_{CC} - 1.295$	V
V_{OUT}	Output Differential Swing Q, /Q	See Figure 1a	150	400		mV
V_{DIFF_OUT}	Differential Output Voltage Swing Q, /Q	See Figure 1b	300	800		mV

LVTTLCMOS DC ELECTRICAL CHARACTERISTICS⁷⁾

$V_{CC} = 2.5V \pm 5\%$ or $3.3V \pm 10\%$; $T_A = -40^\circ C$ to $+85^\circ C$

Symbol	Parameter	Condition	Min	Typ	Max	Units
V_{IH}	Input HIGH Voltage		2.0			V
V_{IL}	Input LOW Voltage				0.8	V
I_{IH}	Input HIGH Current				40	μA
I_{IL}	Input LOW Current		-300			μA

Note:

7. The circuit is designed to meet the DC specifications shown in the above table after thermal equilibrium has been established.

AC ELECTRICAL CHARACTERISTICS

V_{CC} = 2.5V ±5% or 3.3V ±10%; T_A = -40°C to +85°C, R_L = 50Ω to V_{CC}-2V, unless otherwise stated.

Symbol	Parameter	Condition	Min	Typ	Max	Units
f _{MAX}	Maximum Operating Frequency	NRZ Data	10.7			Gbps
		V _{OUT} ≥ 200mV Clock		7		GHz
t _{pd}	Differential Propagation Delay	IN-to-Q	90	160	240	ps
		SEL-to-Q	50	160	350	ps
t _{pd} Tempco	Differential Propagation Delay Temperature Coefficient			75		fs/°C
t _{SKEW}	Input-to-Input Skew	Note 9		3	15	ps
	Part-to-Part Skew	Note 10			100	ps
t _{JITTER}	Data Random Jitter	Note 11			1	ps _{RMS}
	Deterministic Jitter	Note 12			10	ps _{PP}
	Clock Cycle-to-Cycle Jitter	Note 13			1	ps _{RMS}
	Total Jitter	Note 14			10	ps _{PP}
	Crosstalk-Induced Jitter	Note 15			0.7	ps _{RMS}
t _r , t _f	Output Rise/Fall Time	20% to 80%, at full swing	20	40	70	ps

Notes:

8. High frequency AC parameters are guaranteed by design and characterization.
9. Input-to-input skew is the difference in time from an input-to-output in comparison to any other input-to-output. In addition, the input-to-input skew does not include the output skew.
10. Part-to-part skew is defined for two parts with identical power supply voltages at the same temperature and with no skew of the edges at the respective inputs.
11. RJ is measured with a K28.7 comma detect character pattern, measured at 2.5Gbps/3.2Gbps.
12. DJ is measured at 2.5Gbps/3.2Gbps, with both K28.5 and 2²³-1 PRBS pattern.
13. Cycle-to-cycle jitter definition: the variation of periods between adjacent cycles, T_n-T_{n-1} where T is the time between rising edges of the output signal.
14. Total jitter definition: with an ideal clock input of frequency ≤ f_{MAX}, no more than one output edge in 10¹² output edges will deviate by more than the specified peak-to-peak jitter value.
15. Crosstalk is measured at the output while applying two similar frequencies that are asynchronous with respect to each other at the inputs.

SINGLE-ENDED AND DIFFERENTIAL SWINGS

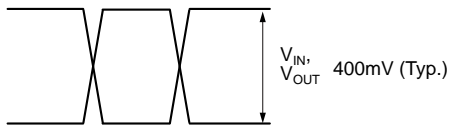

Figure 1a. Single-Ended Voltage Swing

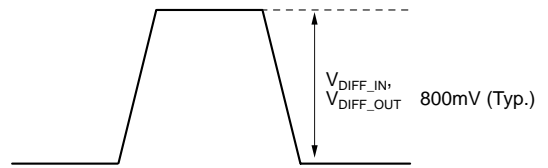
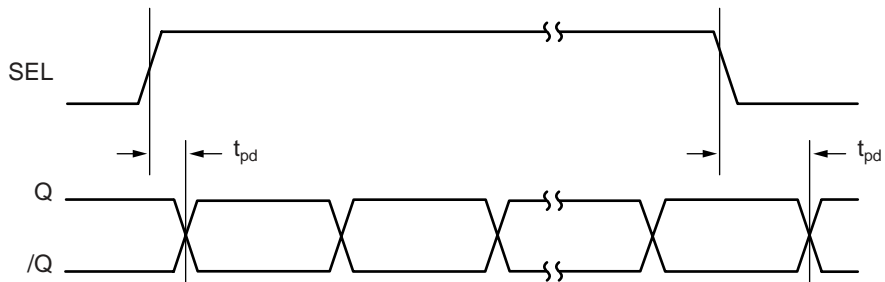
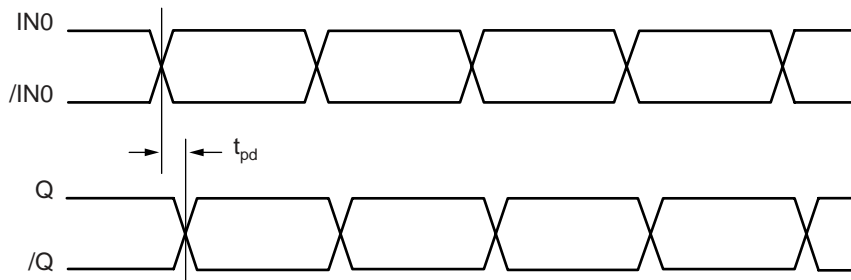

Figure 1b. Differential Voltage Swing

TIMING DIAGRAMS



TYPICAL OPERATING CHARACTERISTICS

$V_{CC} = 3.3V$, $V_{IN} = 100mV$, $T_A = 25^\circ C$, unless otherwise stated.

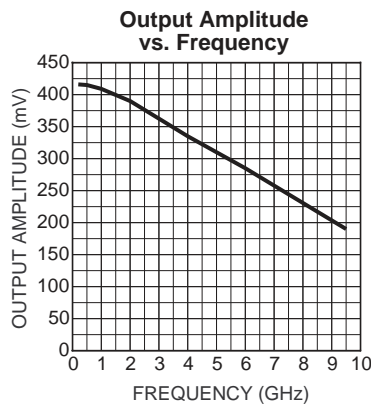
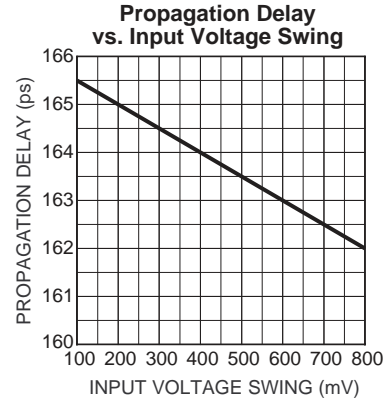
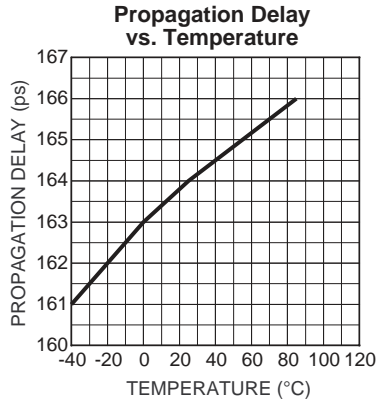

TYPICAL OPERATING CHARACTERISTICS

$V_{CC} = 3.3V$, $V_{IN} = 100mV$, $T_A = 25^\circ C$, unless otherwise stated.

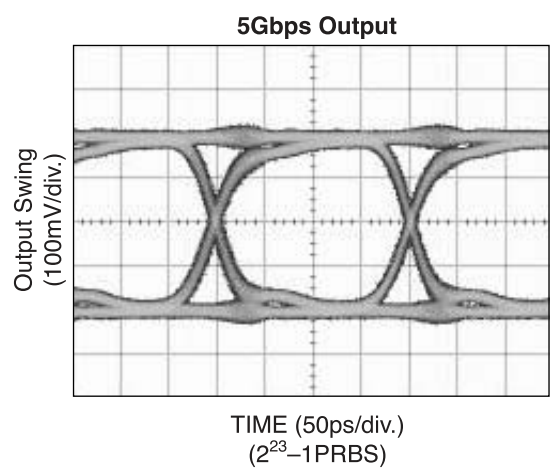
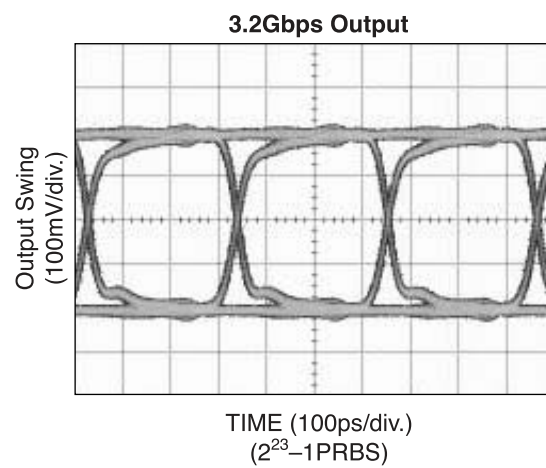
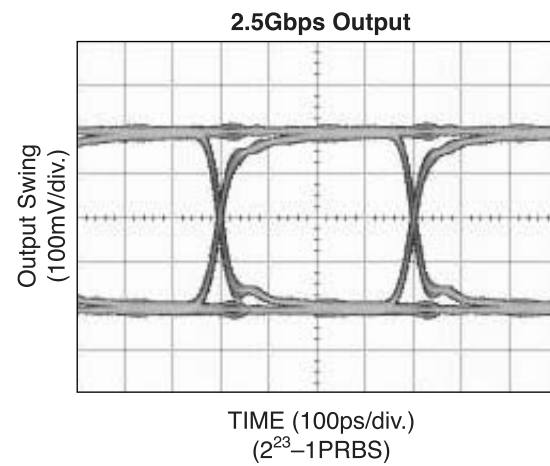
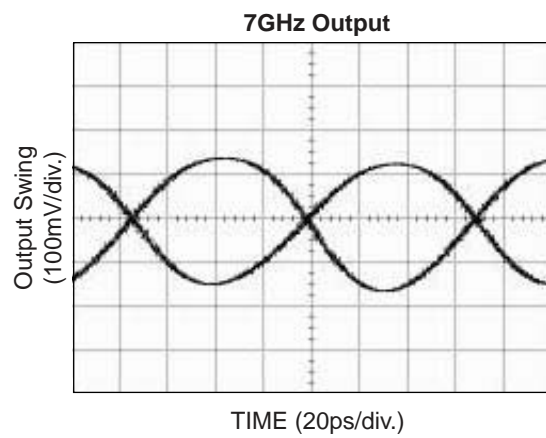
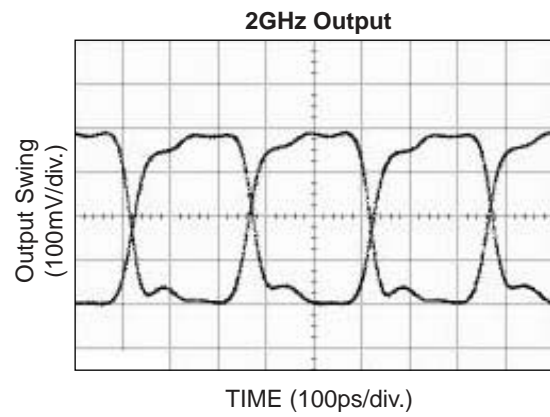
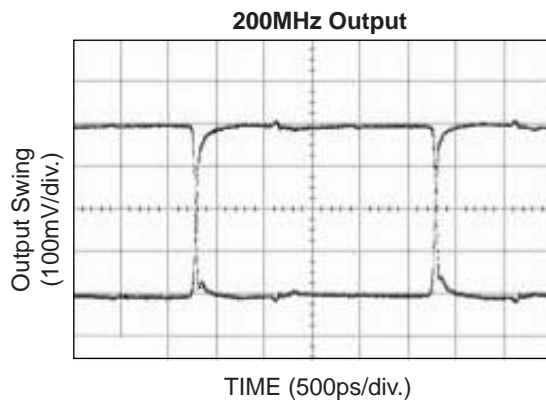

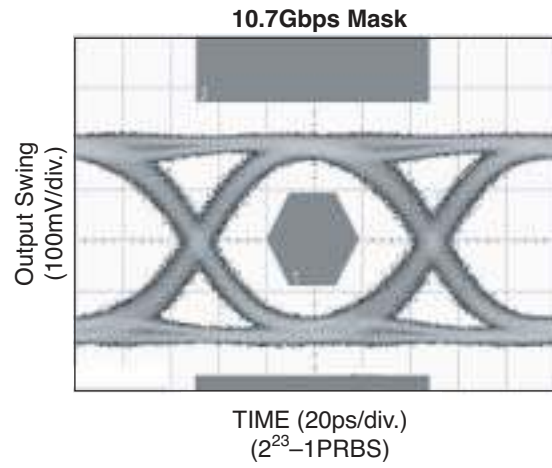
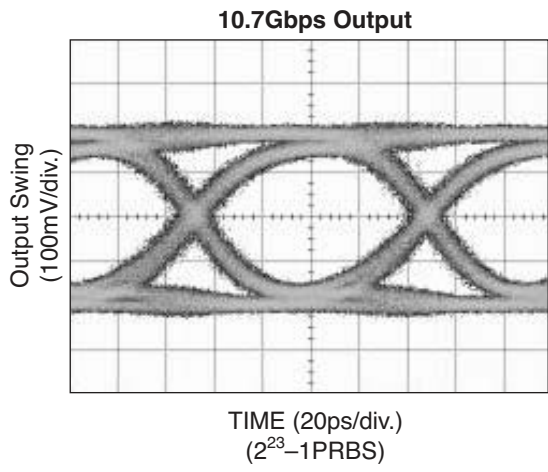

INPUT AND OUTPUT STAGES

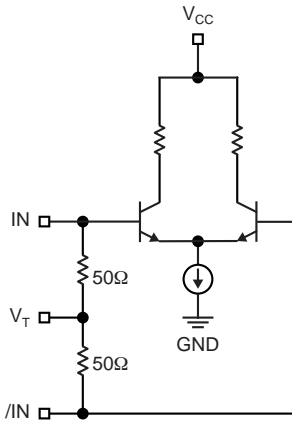

Figure 2a. Simplified Differential Input Stage

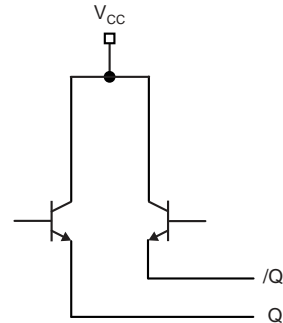

Figure 2b. Simplified LVPECL Output Stage

INPUT INTERFACE APPLICATIONS

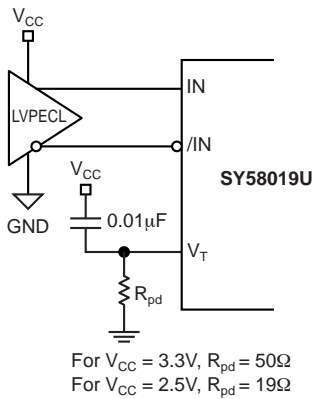

Figure 3a. LVPECL Interface (DC-Coupled)

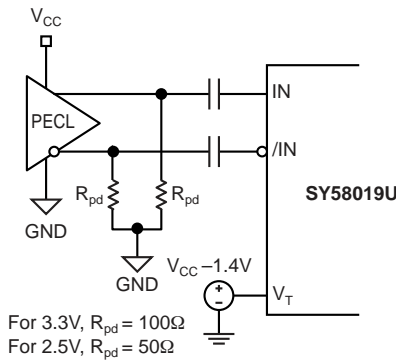

Figure 3b. LVPECL Interface (AC-Coupled)

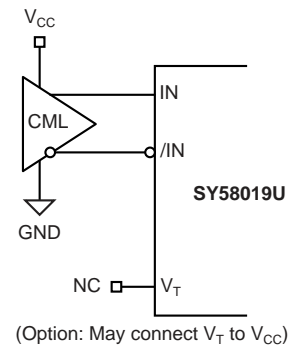

Figure 3c. CML Interface (DC-Coupled)

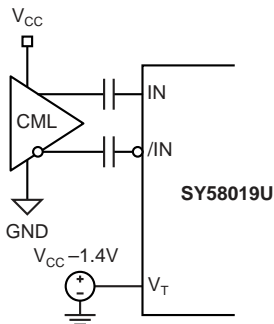

Figure 3d. CML Interface (AC-Coupled)

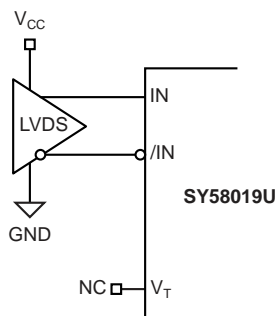

Figure 3e. LVDS Interface

OUTPUT INTERFACE APPLICATIONS

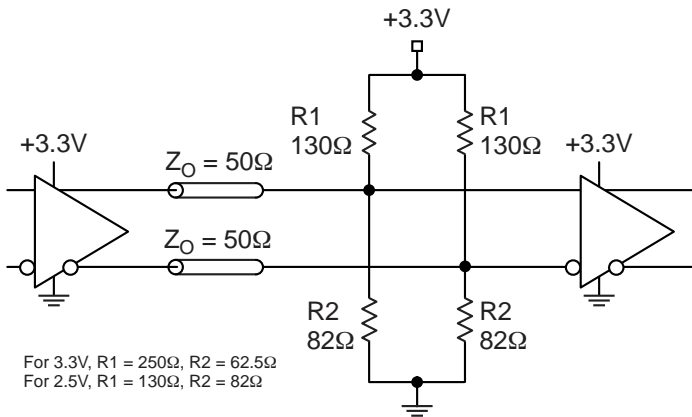

Figure 4a. Parallel Thevenin-Equivalent Termination

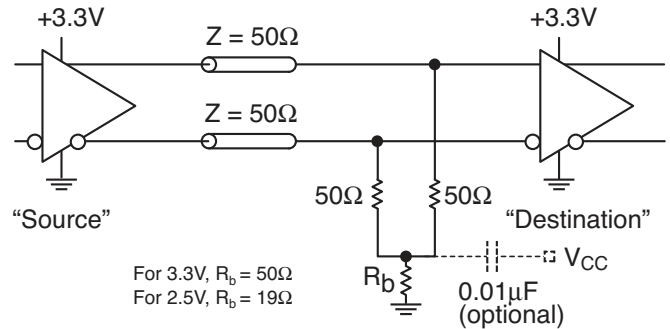

Figure 4b. Three-Resistor “Y” Termination

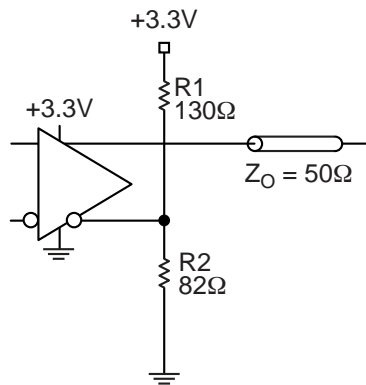
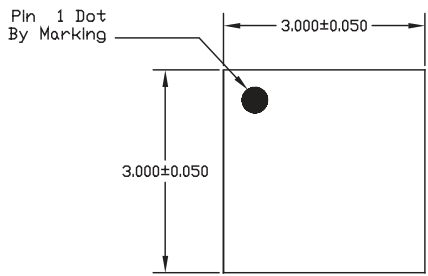

Figure 4c. Terminating Unused I/O

RELATED MICREL PRODUCTS AND SUPPORT DOCUMENTATION

Part Number	Function	Data Sheet Link
SY58016L	3.3V 10Gbps Differential CML Line Driver/Receiver with Internal I/O Termination	http://www.micrel.com/product-info/products/sy58016l.shtml
SY58017U	Ultra Precision Differential CML 2:1 MUX with Internal I/O Termination	http://www.micrel.com/product-info/products/sy58017u.shtml
SY58018U	Ultra Precision Differential LVPECL 2:1 MUX with Internal Termination	http://www.micrel.com/product-info/products/sy58018u.shtml
SY58025U	10.7Gbps Dual 2:1 CML MUX with Internal I/O Termination	http://www.micrel.com/product-info/products/sy58025u.shtml
SY58026U	5Gbps Dual 2:1 MUX with Internal Termination	http://www.micrel.com/product-info/products/sy58026u.shtml
SY58027U	10.7Gbps Dual 2:1 400mV LVPECL MUX with Internal Termination	http://www.micrel.com/product-info/products/sy58027u.shtml
SY58051U	10.7Gbps AnyGate® with Internal Input and Output Termination	http://www.micrel.com/product-info/products/sy58051u.shtml
SY58052U	10Gbps Clock/Data Retimer with 50Ω Input Termination	http://www.micrel.com/product-info/products/sy58052u.shtml
	MLF® Application Note	www.amkor.com/products/notes_papers/MLF_AppNote_0902.pdf
HBW Solutions	New Products and Applications	www.micrel.com/product-info/products/solutions.shtml

16-Pin MicroLeadFrame® (MLF-16)



TOP VIEW

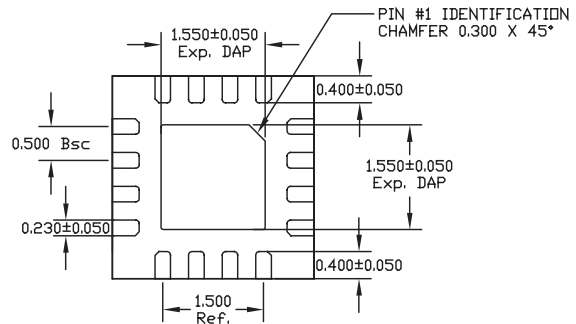

BOTTOM VIEW

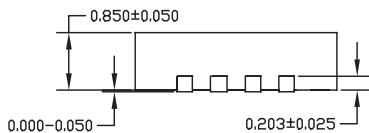

SIDE VIEW

- NOTE:
1. ALL DIMENSIONS ARE IN MILLIMETERS.
 2. MAX. PACKAGE WARPAGE IS 0.05 mm.
 3. MAXIMUM ALLOWABLE BURRS IS 0.076 mm IN ALL DIRECTIONS.
 4. PIN #1 ID ON TOP WILL BE LASER/INK MARKED.

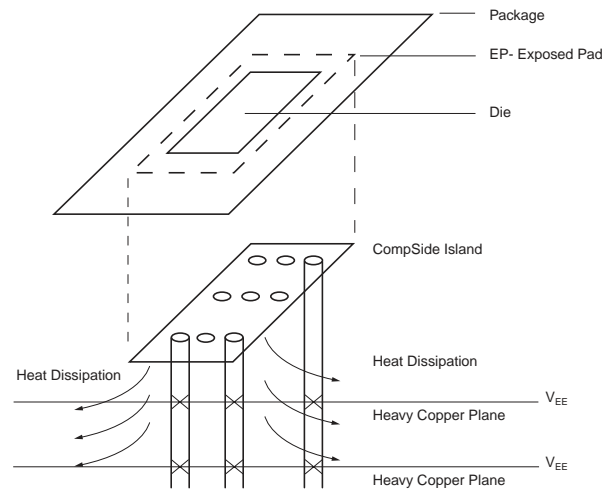

**PCB Thermal Consideration for 16-Pin MLF® Package
(Always solder, or equivalent, the exposed pad to the PCB)**

Package Notes:

1. Package meets Level 2 qualification.
2. All parts are dry-packaged before shipment.
3. Exposed pads must be soldered to a ground for proper thermal management.

MICREL, INC. 2180 FORTUNE DRIVE SAN JOSE, CA 95131 USA

TEL + 1 (408) 944-0800 FAX + 1 (408) 474-1000 WEB <http://www.micrel.com>

The information furnished by Micrel in this data sheet is believed to be accurate and reliable. However, no responsibility is assumed by Micrel for its use. Micrel reserves the right to change circuitry and specifications at any time without notification to the customer.

Micrel Products are not designed or authorized for use as components in life support appliances, devices or systems where malfunction of a product can reasonably be expected to result in personal injury. Life support devices or systems are devices or systems that (a) are intended for surgical implant into the body or (b) support or sustain life, and whose failure to perform can be reasonably expected to result in a significant injury to the user. A Purchaser's use or sale of Micrel Products for use in life support appliances, devices or systems is at Purchaser's own risk and Purchaser agrees to fully indemnify Micrel for any damages resulting from such use or sale.

© 2005 Micrel, Incorporated.