

**BAW Filter 2442.0MHz**

**Part No: MP09118**

**Rev No: 2**

**A. MAXIMUM RATING:**

Electrostatic Sensitive Device (ESD)

1. Input power: 28dBm (Ta = +50°C, 10kh, CW)
2. Maximum DC Voltage: ±3V
3. Operating temperature range: -30°C to +85°C
4. Storage temperature range: -30°C to +85°C
5. Moisture Sensitivity Level: Level 1 (MSL 1)
6. ESD 50V (MM) 100V (HBM)

**B. ELECTRICAL CHARACTERISTICS:**

1. Terminating source impedance:  $Z_S = 50 \parallel 6.8nH$  ( $Q = \infty$ )  $\Omega$  (Single)
2. Terminating load impedance:  $Z_L = 50 \parallel 6.8nH$  ( $Q = \infty$ )  $\Omega$  (Single)

Parameters Description		Unit	Min	Typ	Max	Remarks	
Insertion Loss integrated(*1)(*2)	2402.5 ~ 2421.5MHz	dB	-	1.4	2.0		
	2407.5 ~ 2426.5MHz	dB		1.3	1.9		
	2412.5 ~ 2471.5MHz	dB		1.3	1.8		
	2457.5 ~ 2476.5MHz	dB		1.3	2.0		
	2462.5 ~ 2481.5MHz	dB	--	1.5	2.4		
Amplitude ripple(*2)	2402.5 ~ 2421.5MHz	dB	-	0.6	1.5		
	2407.5 ~ 2426.5MHz	dB		0.5	1.4		
	2412.5 ~ 2471.5MHz	dB		0.5	1.3		
	2457.5 ~ 2476.5MHz	dB		0.5	1.5		
	2462.5 ~ 2481.5MHz	dB		0.7	1.9		
VSWR	Input	2402.5 ~ 2481.5MHz	-	-	1.5	2.0	
	Output	2402.5 ~ 2481.5MHz	-	-	1.5	2.0	
Attenuation:							
800 ~ 2300MHz		dB	35	39	-		
2300 ~ 2370MHz		dB	48	51	-	(*3)	
2500 ~ 2505MHz		dB	23	61	-	-30°C to -10°C(*3)	
		dB	30		-	-10°C to +25°C(*3)	
		dB	42		-	+25°C to +85°C(*3)	
2505 ~ 2570MHz		dB	47	52	-	(*3)	
2570 ~ 2620MHz		dB	42	48	-	(*3)	
2620 ~ 2690MHz		dB	42	45	-	(*3)	
2690 ~ 7500MHz		dB	30	39	-		

(\*1) Specification of Insertion loss excludes loss that comes from the test board.

(\*2) The integrated loss over any 19MHz channel within the band.

(\*3) The integrated loss over any 5MHz channel within the band.

**BAW Filter 2442.0MHz**

**Part No: MP09118**

**Rev No: 2**

**C. FREQUENCY CHARACTERISTICS:**

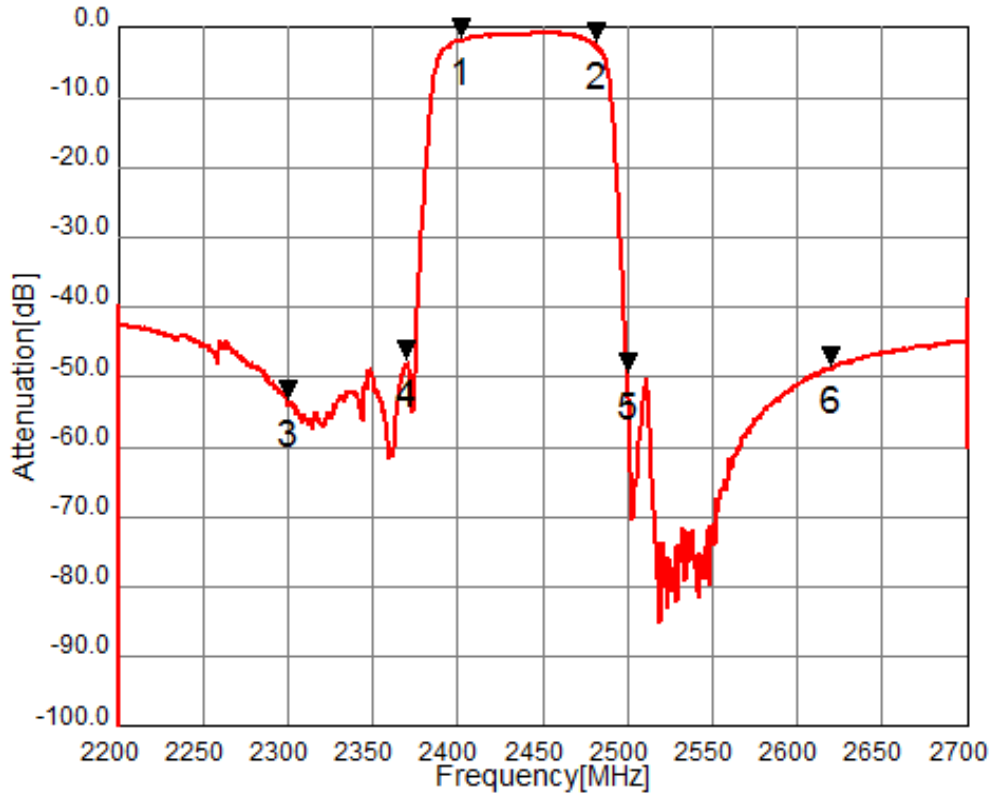

Mk1: 2402.5MHz	S21=-1.914dB
Mk2: 2481.5MHz	S21=-2.644dB
Mk3: 2300.0MHz	S21=-53.617dB
Mk4: 2370.0MHz	S21=-48.145dB
Mk5: 2500.0MHz	S21=-49.944dB
Mk6: 2620.0MHz	S21=-48.822dB

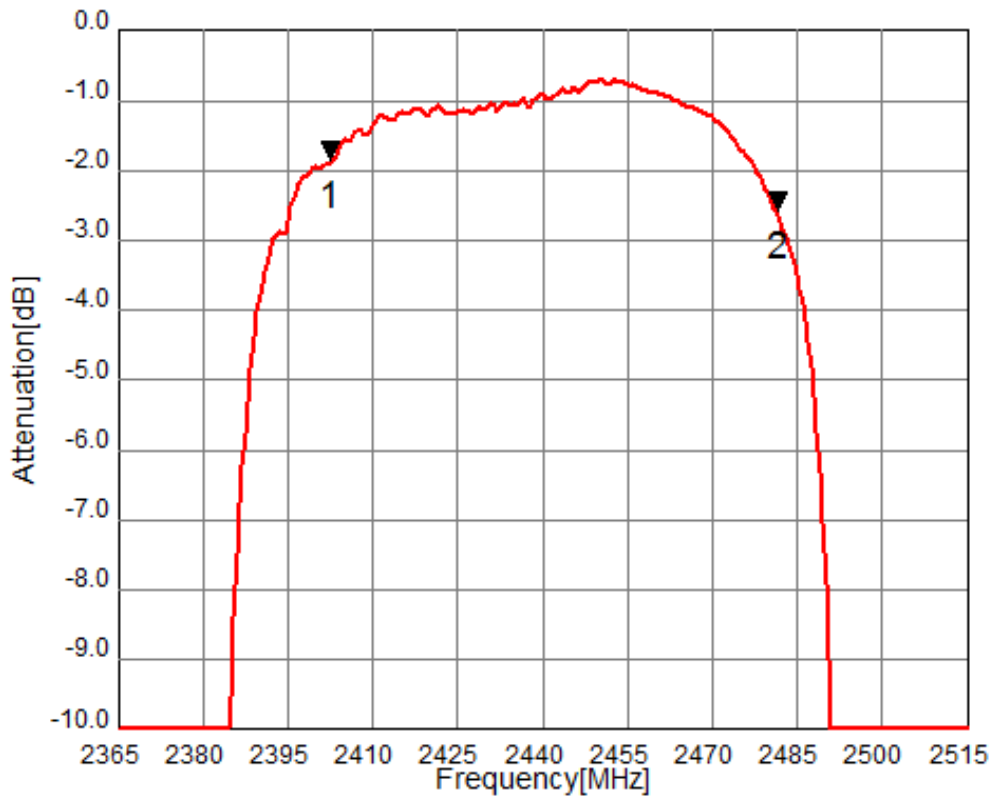

Mk1: 2402.5MHz	S21=-1.914dB
Mk2: 2481.5MHz	S21=-2.644dB

**BAW Filter 2442.0MHz**

**Part No: MP09118**

**Rev No: 2**

1. Input Port

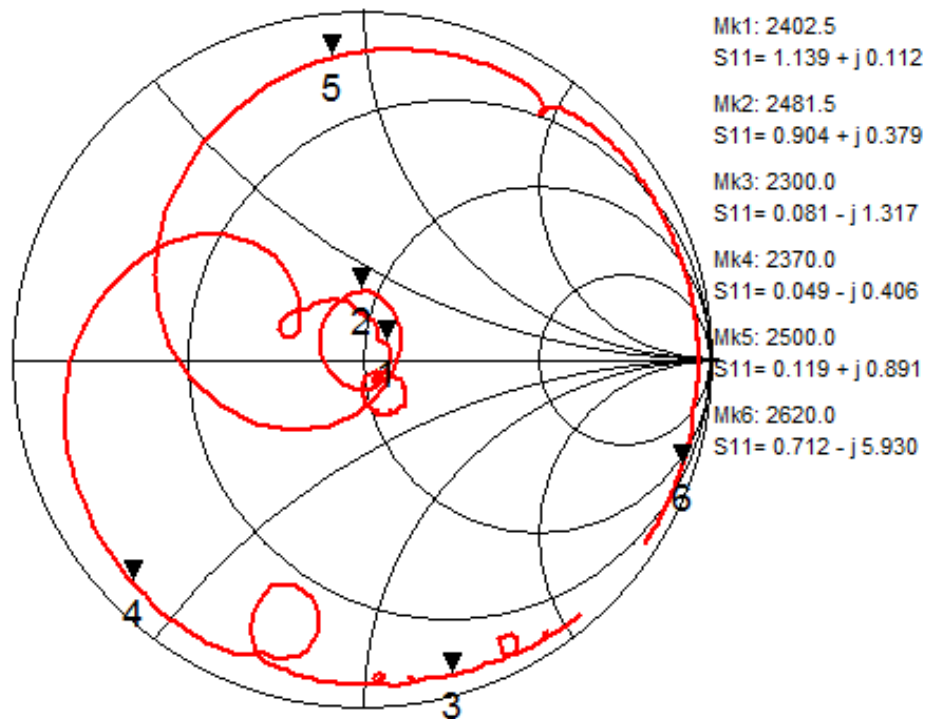
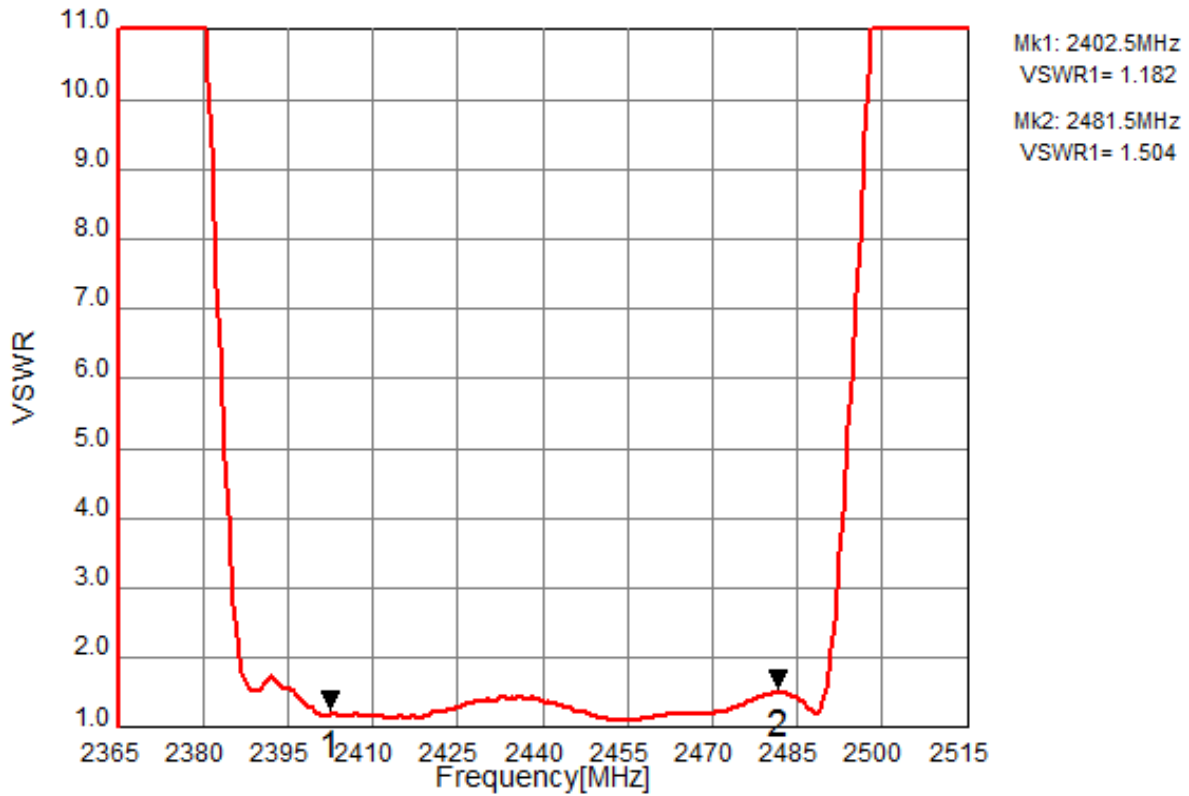

**BAW Filter 2442.0MHz**

**Part No: MP09118**

**Rev No: 2**

2. Output Port

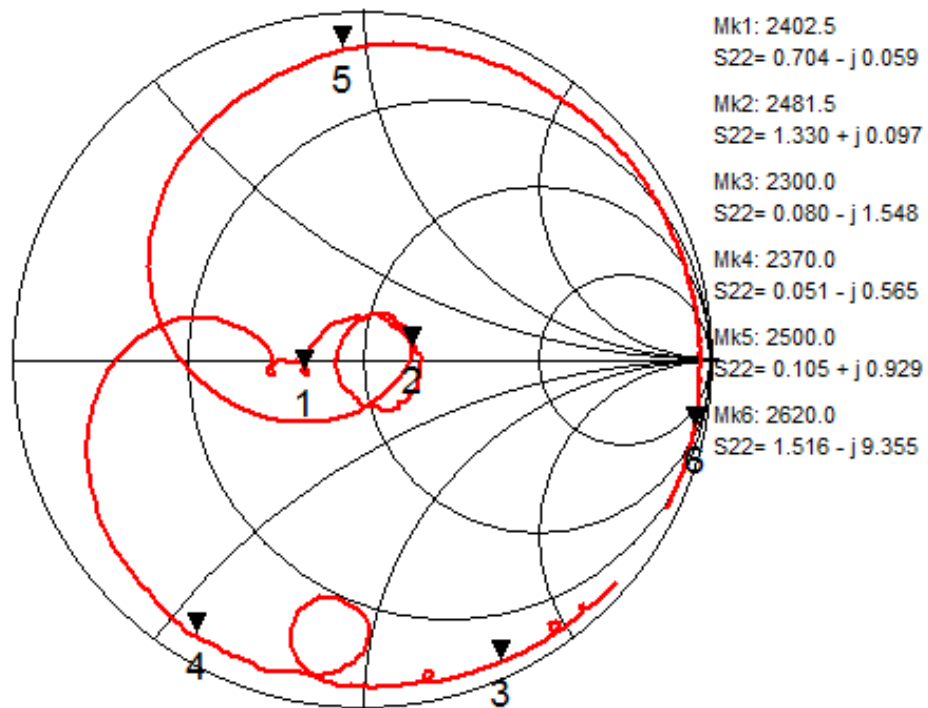
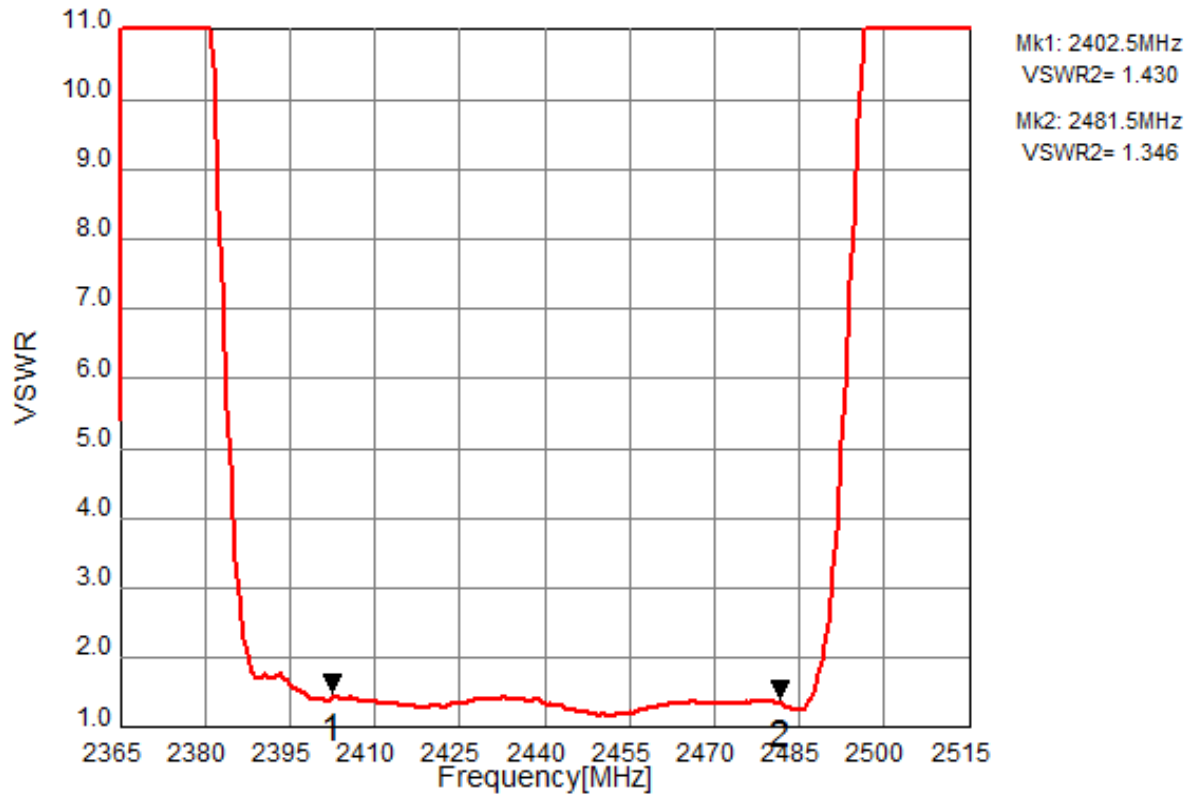

**BAW Filter 2442.0MHz**

**Part No: MP09118**

**Rev No: 2**

3. Wideband

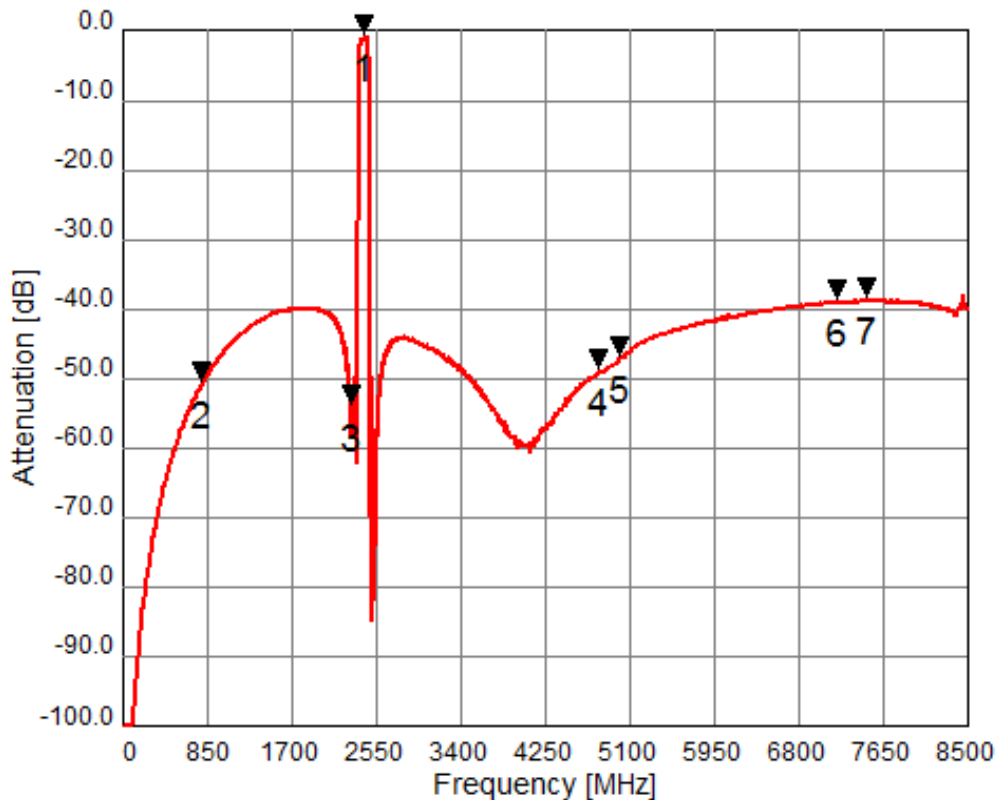
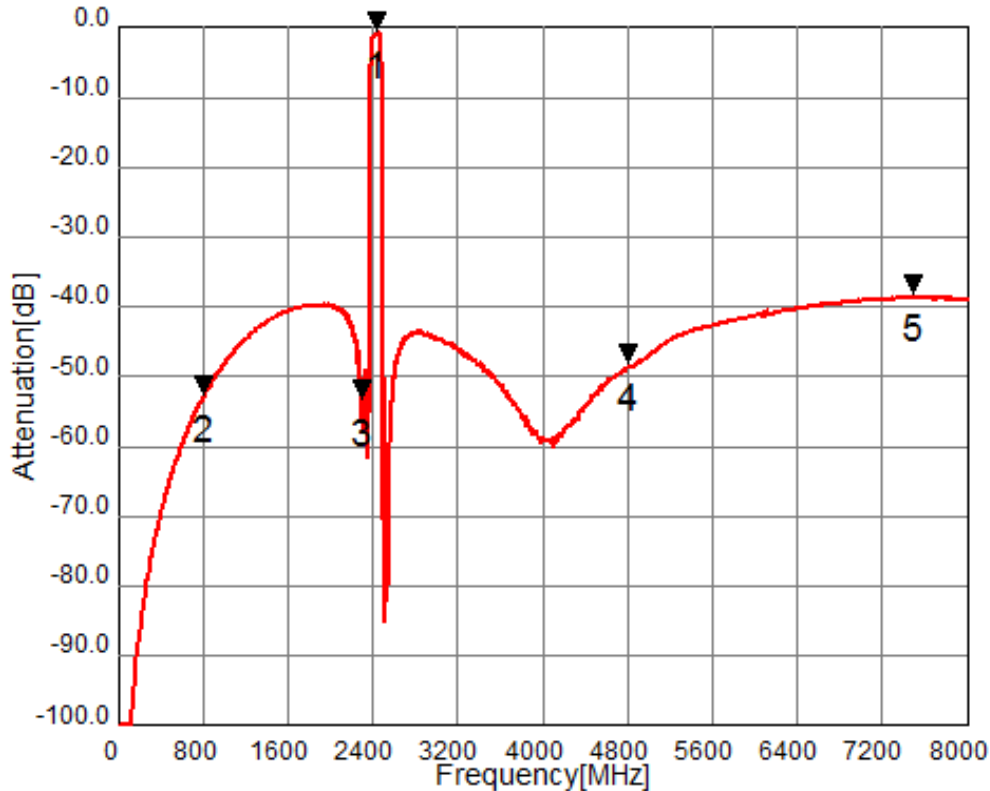

**BAW Filter 2442.0MHz**

**Part No: MP09118**

**Rev No: 2**

**D. OUTLINE DRAWING:**

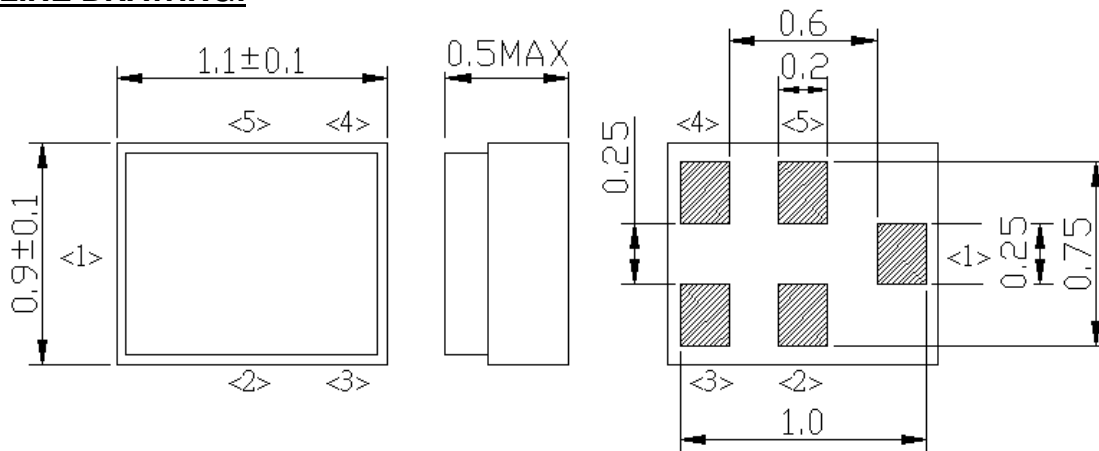

**Pin Configuration**

Pin No.	Symbol	Function
1	IN	Input
2	GND	Ground
3	GND	Ground
4	OUT	Output
5	GND	Ground

**E. EVALUATION CIRCUIT:**

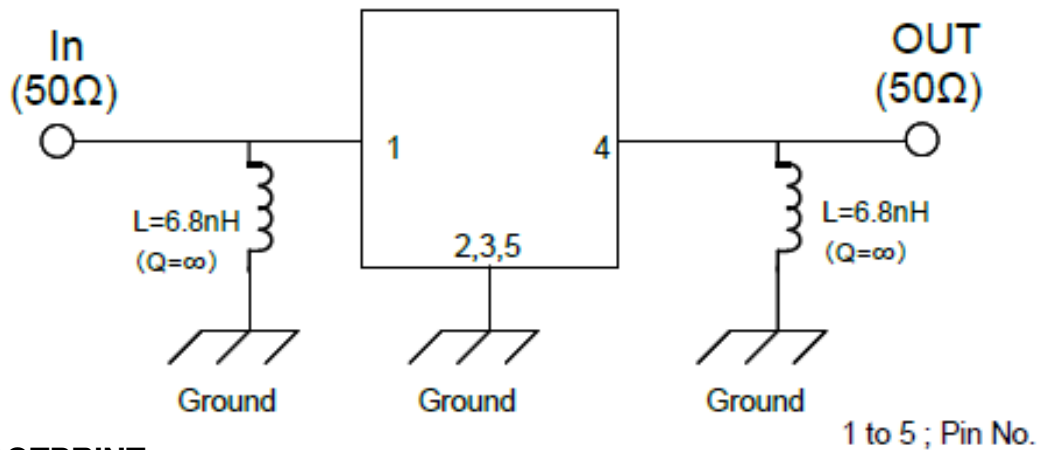

**F. PCB FOOTPRINT:**

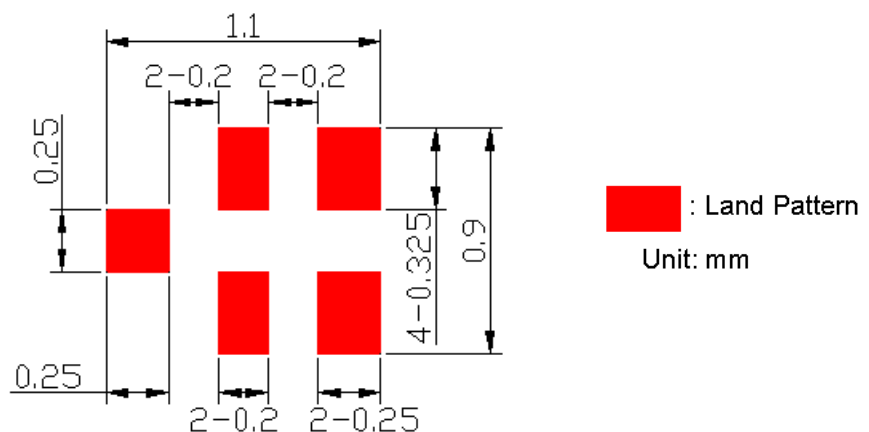

: Land Pattern  
 Unit: mm

**BAW Filter 2442.0MHz**

**Part No: MP09118**

**Rev No: 2**

**G. PACKING:**

1. Reel Dimension

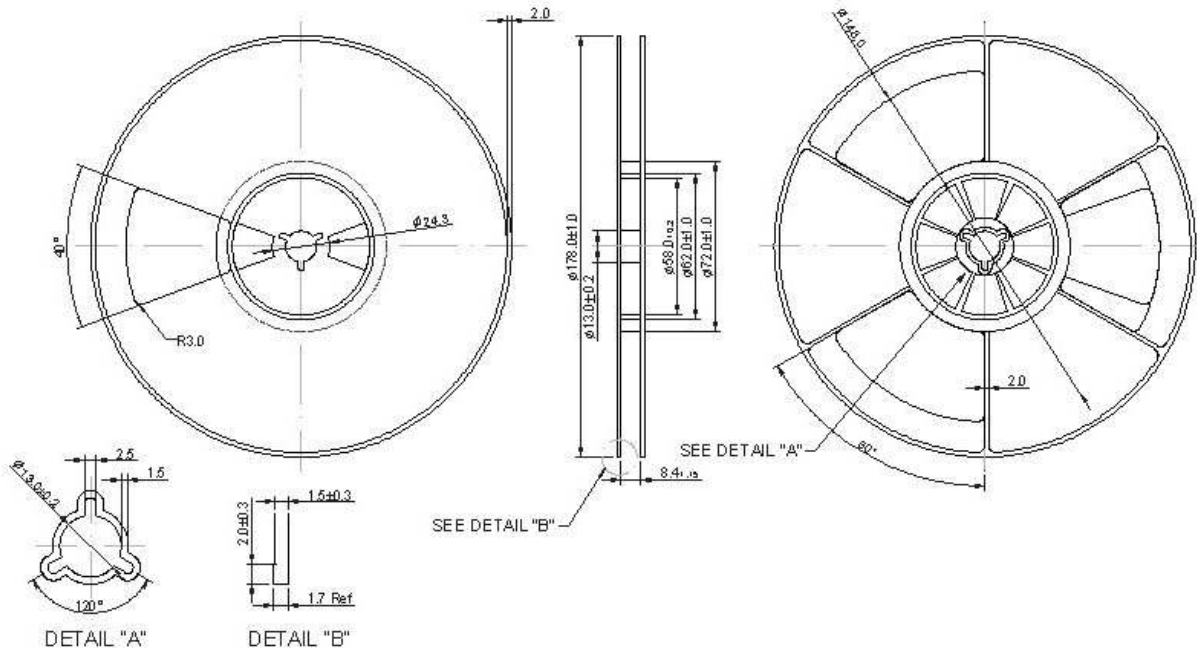

2. Tape Dimension

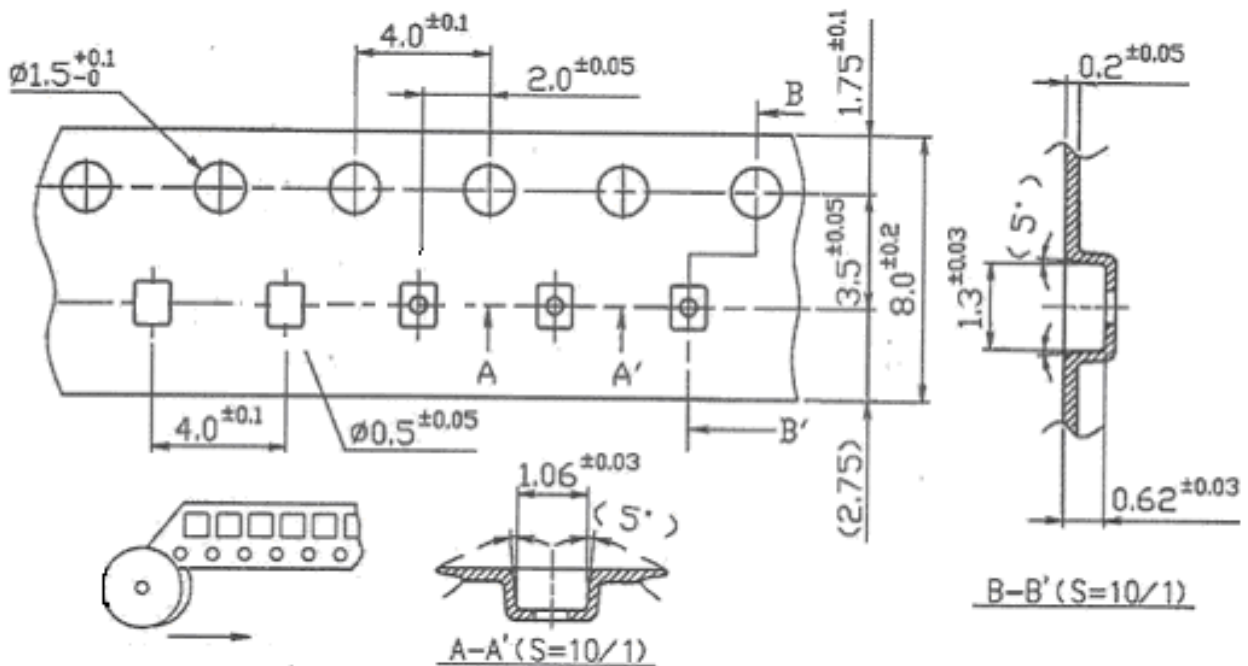

**BAW Filter 2442.0MHz**

**Part No: MP09118**

**Rev No: 2**

**H. RECOMMENDED REFLOW PROFILE:**

1. Preheating shall be fixed at 150 ~ 180°C for 60 ~ 90 seconds.
2. Ascending time to preheating temperature 150°C shall be 30 seconds min.
3. Heating shall be fixed at 220°C for 50 ~ 80 seconds and at 245 ~ 260°C peak (min. 10 sec).
4. Time: 2 times.

