

LOGO FONT: 1.20 HIGH
BOOKMAN OLD STYLE

32 VDI TEXTURE
ON ALL SURFACES
BELOW THIS LINE

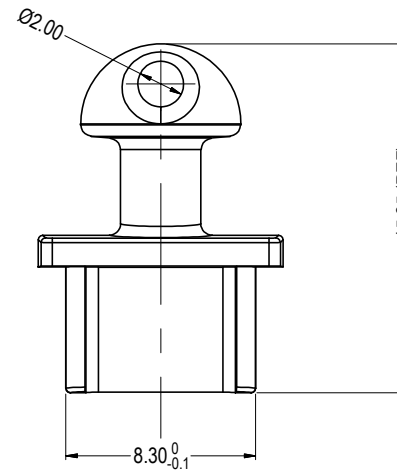
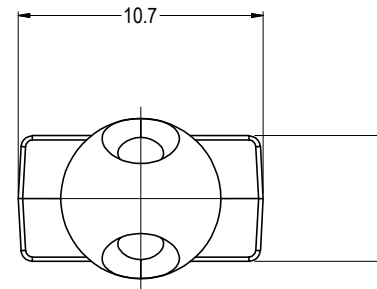
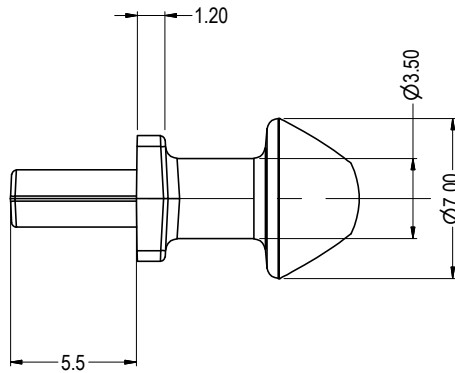
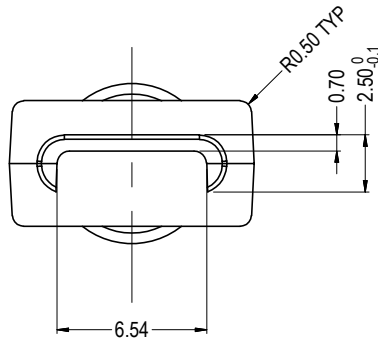
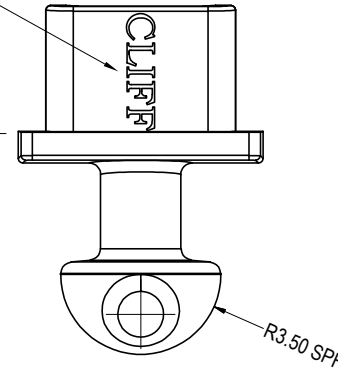

PART No.	COLOUR
CP30295	BLACK
CP30295W	WHITE

NOTES:-

- PART TO BE MADE FROM 3D DATA SUPPLIED.
- GATE AND EJECTOR POSITIONS TO BE AGREED.
- PART TO BE FREE FROM FLASH, SINK MARKS AND OTHER SURFACE DEFECTS.

ISS.	AMEND	DATE
1	ISSUED	23/08/18
2	WHITE ADDED	15/11/19

RoHS
COMPLIANT

TOLERANCE
NO DEC. PLACE ± 0.50
1 DEC. PLACE ± 0.20
2 DEC. PLACE ± 0.10
HOLE Ø ± 0.10
ANGLES ± 1/2°
UNLESS
OTHERWISE STATED

DO NOT SCALE

Cliff Electronic Components Ltd.

76 Holmethorpe Avenue, Holmethorpe Industrial Estate,
Redhill, Surrey, RH1 2PF, England, UK
Tel: 01737-771375 Fax: 01737-766012 Website: www.cliffuk.co.uk

DIMENSIONS IN MILLIMETERS UNLESS OTHERWISE STATED. WORK TO DIMENSIONS. REMOVE ALL BURRS. IF IN DOUBT ASK.

3rd ANGLE PROJECTION:

MATERIAL: POLYPROPYLENE

TITLE: DUST COVER - USB-C

FINISH: 32 VDI, AS SHOWN - COLOUR SEE TABLE

DRAWN: NJB

APPROVED: DPJ

DRWG. No. **CP30295**

FORM: A4DRWGH