

High Efficiency Off-Line CC/CV Switch

FEATURES

- Constant-Current (CC) and Constant-Voltage (CV) with Primary Side Control
- Proprietary technology enabling high efficiency and fast dynamic response
- Satisfy DoE Level 6 requirements from 5V/1A to 5V/2.4A applications
- No audible noise over entire operating range
- Optimization for capacitive loading
- Built-in power NPN/MOS
- Built-in Cable Compensation
- Built-in Line Compensation
- Primary-side feedback eliminates opto-coupler and TL431
- Cycle-by-Cycle Current Limiting
- Over Temperature Protection
- VCC Over Voltage Protection
- CV Open-loop Protection
- Excellent capacitive loading start-up performance

TYPICAL APPLICATION

- Adapter/Charger for Cell/Cordless Phones, PDAs, MP3 and Other Portable Apparatus
- Standby and Auxiliary Power Supplies Set Top Boxes (STB)
- Adapter for ADSL / WiFi Wireless
- AC/DC LED Driver applications

DESCRIPTION

The FT839NX/FT839MX controller device is optimized for high-performance, low power switching mode power supply applications. The FT839NX/FT839MX facilitates CC/CV charger design by eliminating an opto-coupler and TL431. Its highly integrated functions such as Under Voltage Lockout (UVLO), Leading Edge Blanking (LEB) and built-in cable compensation offer the users a high efficiency and low cost solution for AC/DC power applications.

Power supplies built with FT839NX/FT839MX can achieve both highest average efficiency, fast dynamic load response and super low standby power. FT839NX and FT839MX satisfy DoE Level 6 requirements with production margin from 5V/1A to 5V/2.4A applications, respectively.

Furthermore, FT839NX/FT839MX features fruitful protections like Open Circuit Protection and Over Temperature Protection to eliminate the external protection circuits and provide reliable operations. FT839NX is available in SOP8/DIP8 package. FT839MX is available in SOP8 package.

TYPICAL APPLICATION CIRCUIT

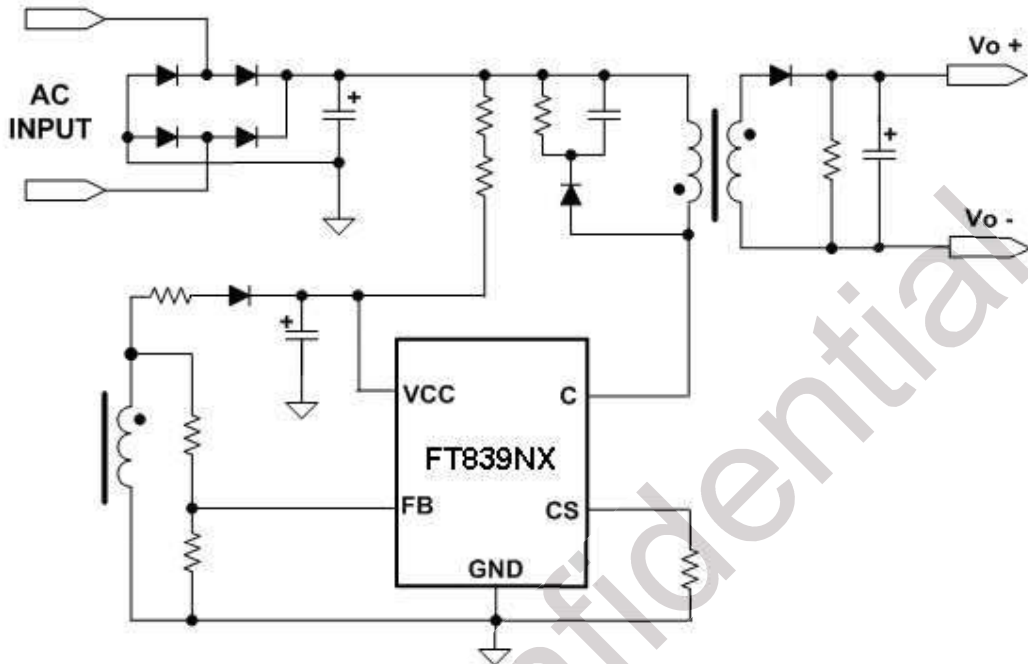

Figure 1.1: FT839NX Typical Application Circuit

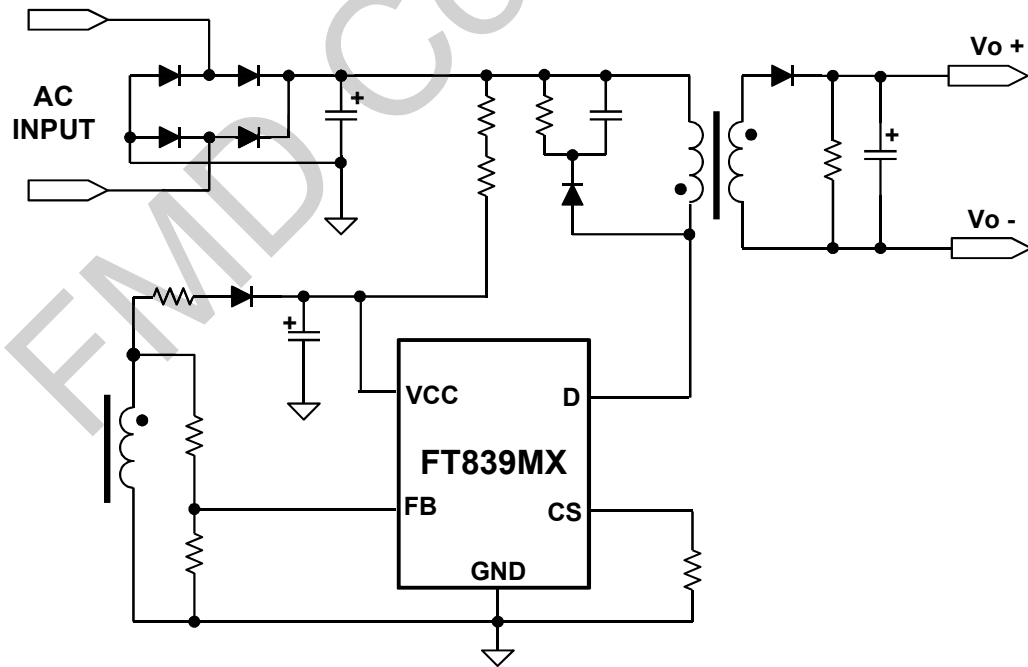

Figure 1.2: FT839MX Typical Application Circuit

ABSOLUTE MAXIMUM RATINGS

FB to GND.....	-0.3V to +7V
CS to GND.....	-0.3V to +7V
VCC to GND.....	-0.3V to +30V
C to GND.....	-0.3V to +700V
D to GND.....	-0.3V to +650V
Operating Temperature Range.....	-40°C to +125°C
Junction Temperature.....	-40°C to +150°C
Storage Temperature Range	-60°C to +150°C
ESD Protection HBM.....	2000V
ESD Protection MM.....	200V

****Stresses exceeding Maximum Ratings may damage the device. Maximum Ratings are stress ratings only. Functional operation above the Recommended Operating Conditions is not implied. Extended exposure to stresses above the Recommended Operating Conditions may affect device reliability.***

PIN CONFIGURATION

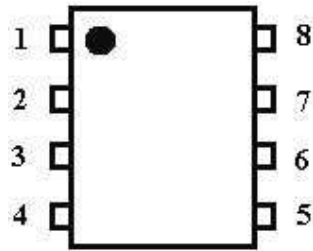

Figure 2: Pin Assignments

TERMINAL DEFINITION

Pin	Name	Description
1	CS	Primary current sense
2	FB	Output voltage feedback pin
3	GND	Ground.
4	VCC	Supply voltage
5	NC	No connection
6		
7	C or D	C: the Collector of the power NPN for FT839NX; D: the Drain of the power MOS for FT839MX. This pin is connected to the primary lead of the transformer
8		

Table 1

ORDERING INFORMATION

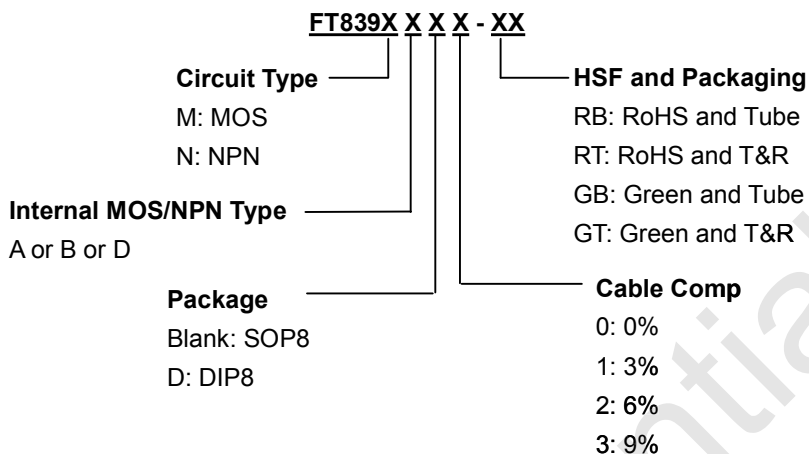

FT839NX①/FT839MX①

Device	DESIGNATOR	SYMBOL	Options
FT839NA①	①	0	Cable Comp = 0%
FT839NB①		1	Cable Comp = 3%
FT839ND①		2	Cable Comp = 6%
FT839NDD①		3	Cable Comp = 9%
FT839MB①			

Table 2

MARKING RULE

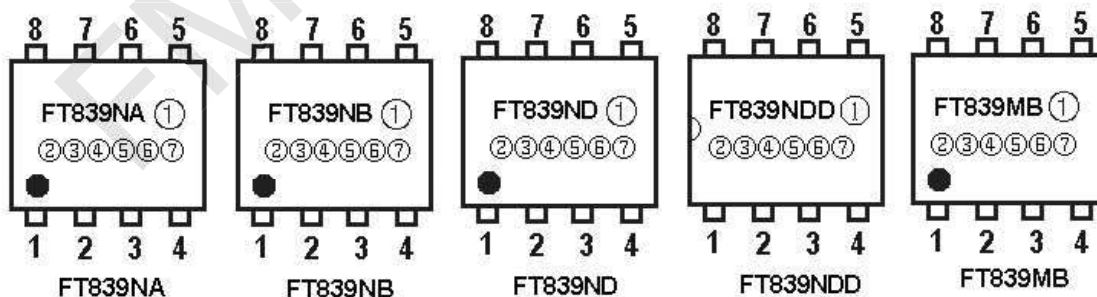

Figure 3: Marking Rule

- ①: Represents Version (0, 1, 2 or 3)
- ②③④⑤⑥⑦: for internal reference

Block Diagram

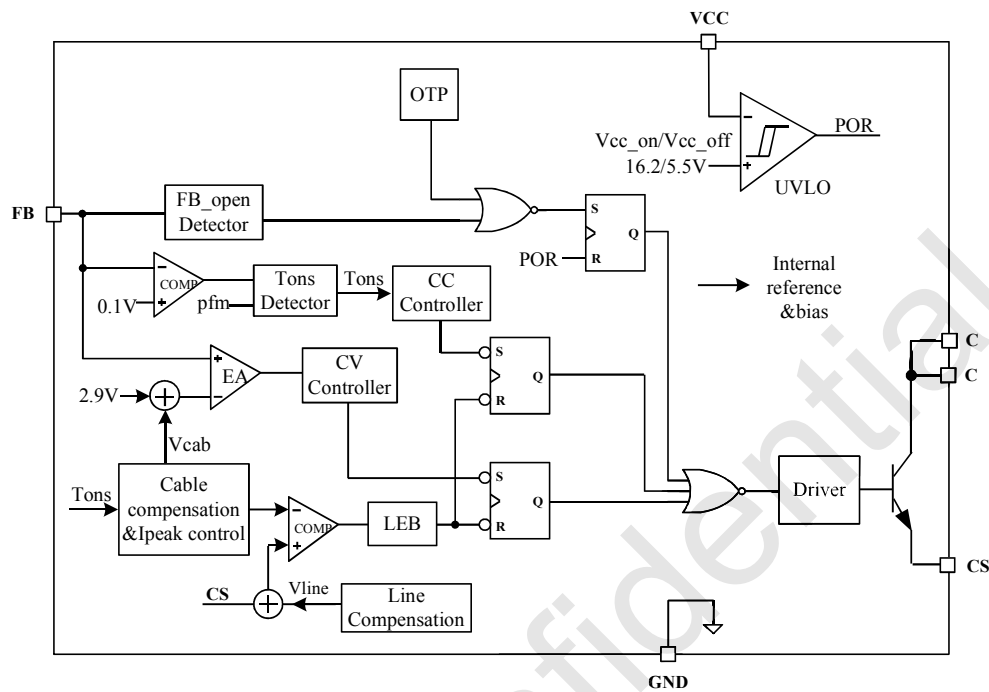

Figure 4.1: FT839NX Block Diagram

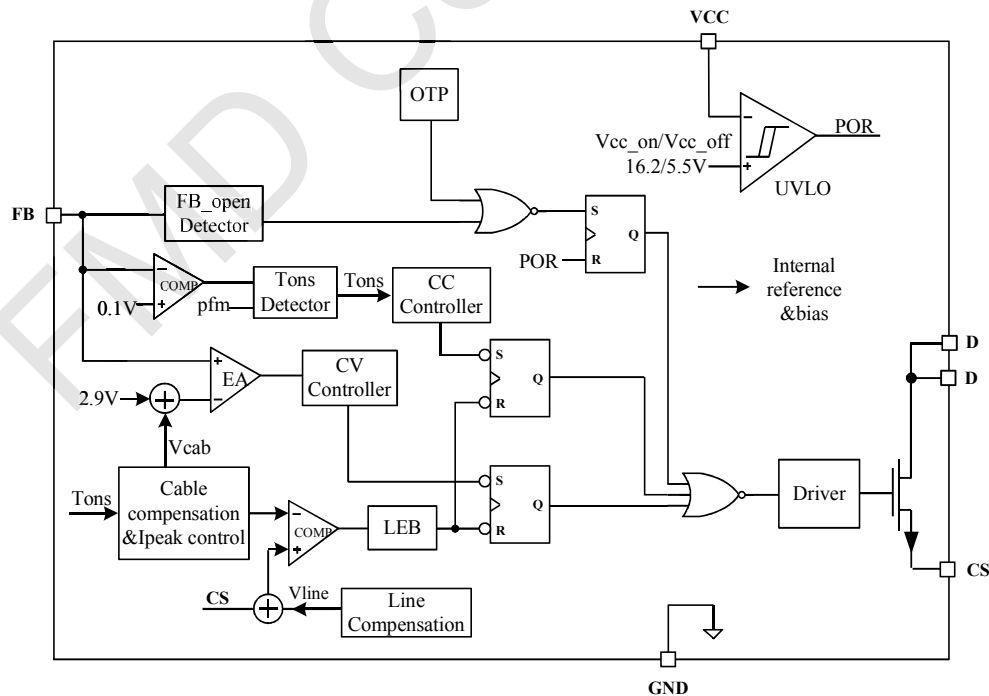

Figure 4.2: FT839MX Block Diagram

ELECTRICAL CHARACTERISTICS

(For typical values Tj=25°C, Vcc=12V, unless otherwise noted)

Characteristic		Symbol	Min	Typ	Max	Unit
Current Sense						
Maximum Current Threshold		Vcs_max	541	552	563	mV
Leading Edge Blanking Duration		Tleb	350	400	450	ns
Propagation Delay (OUT=1.0nF to GND)		Tpd			200	ns
Secondary DutyCycle						
Secondary Maximum DutyCycle		Ds_max		47		%
Feedback Section						
Feedback Voltage Threshold		Vfb	2.856	2.9	2.944	V
CCM protection Threshold Level		Vcp		100		mV
Supply Section						
Start Up Threshold Voltage		Vcc_on	15.5	16.2	17.5	V
Under Voltage Lockout Voltage		Vcc_off	5.2	5.5	6.0	V
VCC Start Up Current		Istart_up		2	5	uA
Operating Current		Iop	0.4	0.5	0.7	mA
Protection Section						
Feedback Loop Open Protection		Ifb_open	90	115	140	uA
VCC Over Voltage Protection		Vcc_OVP	26	27	28	V
Over Temperature Protection		T_OTP		145		°C
Compensation						
Line Compensation (I _{fb} =1mA)		Vline	25	33	40	mV
Cable compensation	0	Kcab		0		%
	1			3		
	2			6		
	3			9		
Power NPN Section (FT839NX)						
Characteristic	Test condition	Symbol	Min	Typ	Max	Unit
Collector-Base breakdown voltage	I _c =0.1mA	V _{cbo}	700			V
Collector-Emitter breakdown voltage	I _c =1mA	V _{ceo}	400			V
Emitter-Base breakdown voltage	I _E =0.1mA	V _{ebo}	9			V
Collector-Emitter saturation voltage	I _B =0.25A, I _C =1A	V _{CEsat}		0.3	0.9	V
Base-Emitter saturation voltage	I _B =0.25A, I _C =1A	V _{BEsat}		0.9	1.2	V
Maximum collector		FT839NA	I _{cm}	0.39		A

current		FT839NB		0.40		
		FT839ND		0.70		
		FT839NDD		0.80		
Power MOS Section (FT839MB)						
Static drain-source on-resistance	R_{DS_ON}	$V_{GS}=10V,$ $I_{DS}=0.5A$		4.5		Ω
Drain-source breakdown voltage	BV_{DSS}	$V_{GS}=0V,$ $I_{DS}=250\mu A$	650			V
Drain-source leakage current	I_{DSS}	$V_{GS}=0V,$ $V_{DS}=650V$			10	μA
Maximum Drain Current	I_{DMAX}		0.65			A

Table 3

FUNCTIONAL DESCRIPTION**Operating Description**

FT839NX/FT839MX is a cost effective and high-performance AC-DC power supply controller for off-line low power AC-DC applications including battery chargers, adaptors and LED lighting. The constant voltage (CV) and constant current (CC) control are achieved accurately without the secondary feedback circuit.

Start up Control

Start-up current of FT838NX/FT839MX is very low so that a start-up resistor with high resistance and low-wattage is allowed to supply the start-up power for the controller. The large value startup resistor minimizes the power loss in operations and allows quick start up. With a special fast startup technology, FT839NX/FT839MX starts up easily in capacitive loading applications.

Operating current

The operating current of FT839NX/FT839MX is as low as 500uA. Good efficiency is achieved with the low operating current. Low operating current also reduces the Vcc hold-up capacitance requirement.

Constant voltage (CV) and constant current (CC) Operation

The FT839NX/FT839MX can accurately achieve CV/CC characteristic output without secondary side voltage and current-feedback circuits. It operates in CV mode to regulate the output voltage by capturing the auxiliary winding feedback voltage at FB pin. The auxiliary winding feedback voltage is proportional to secondary winding, so it provides controller the feedback signal from secondary side and achieves constant-voltage output. In CC mode, the controller detects the secondary discharger peak current and the discharger time, which determines the off-time of the base driver to make the output average current constant.

Primary peak current modulation

Primary peak current is constant at constant current mode. And primary peak current is modulated at constant voltage mode for the purposes of good dynamic load response and no audible noise over entire operating range. According to the output loading current the current threshold voltage is modulated from 0.55V to 0.27V. The current threshold voltage is 0.55V at rated load and 0.27V at light load.

Leading edge blanking

Each time the power NPN or MOS transistor is switched on, a turn-on spike occurs at the sense resistor. To avoid premature termination of the switching pulse, a 400ns leading edge blanking time is built in. Conventional RC filtering can therefore be omitted. During this blanking period, the current limit comparator is disabling and cannot switch off the base driver.

Under voltage lockout (UVLO)

FT839NX/FT839MX turn-on Vcc_on and turn-off Vcc_off are 16.2 V and 5.5 V, respectively. During start-up, the hold-up capacitor must be charged to 16.2V through the start-up resistor. The hold-up capacitor continues to supply Vcc until power can be delivered from the auxiliary winding of the

transformer. Vcc must not drop below 5.5 V during this start-up process. This UVLO hysteresis window ensures that hold-up capacitor is sufficient to supply Vcc during start-up.

Protection control

With rich protection features of FT839NX/FT839MX, excellent power supply system reliability can be achieved. The protection features include cycle by cycle current limiting, Vcc over voltage protection and clamp, over temperature protection, feedback loop open circuit protection and Vcc under voltage lockout, etc.

Integrated NPN/MOS

Power NPN/MOS is integrated in FT839NX/FT839MX for low cost and/or space limited applications, respectively.

Output cable compensation

The output cable compensation provides a constant output voltage at the end of the cable over the entire load range in constant voltage mode. As the converter load increases from no-load to the peak current load, the voltage drop introduced across the output cable is compensated by increasing the feedback pin reference voltage.

SOP8 PACKAGE OUTLINE DIMENSIONS

SOP8 Package

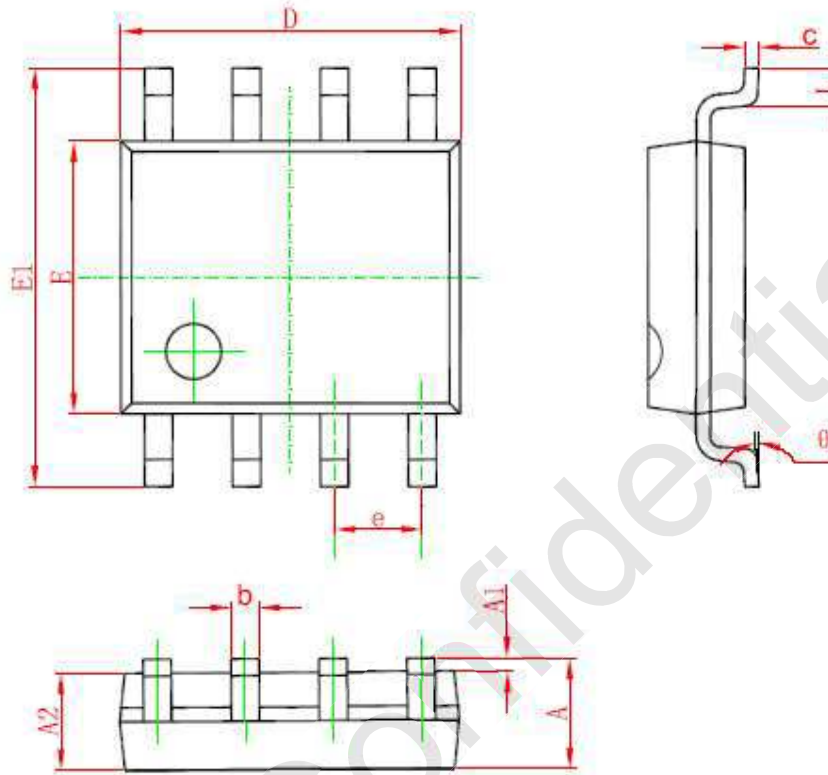

Symbol	Dimensions In Millimeters		Dimensions In Inches	
	Min	Max	Min	Max
A	1.350	1.750	0.053	0.069
A1	0.100	0.250	0.004	0.010
A2	1.350	1.550	0.053	0.061
b	0.330	0.510	0.013	0.020
c	0.170	0.250	0.006	0.010
D	4.700	5.100	0.185	0.200
E	3.800	4.000	0.150	0.157
E1	5.800	6.200	0.228	0.244
e	1.270 (BSC)		0.050 (BSC)	
L	0.400	1.270	0.016	0.050
theta	0°	8°	0°	8°

DIP8 PACKAGE OUTLINE DIMENSIONS

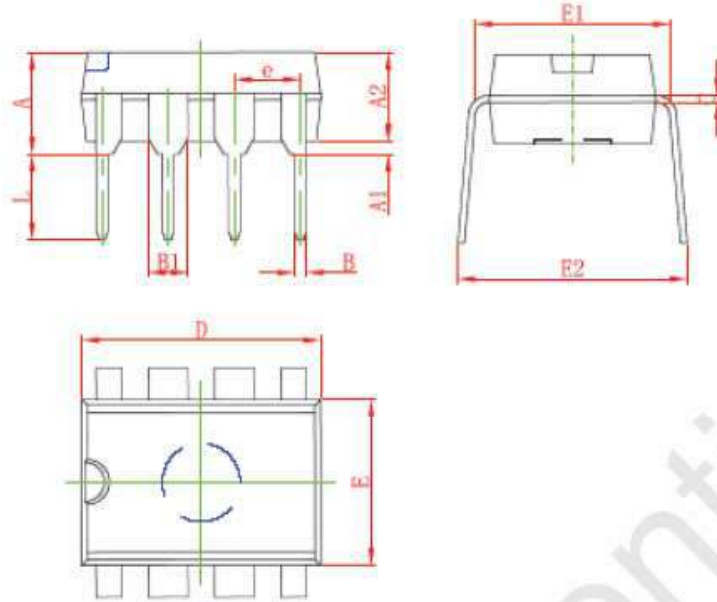

Symbol	Dimensions in Millimeters		Dimensions in Inches	
	Min	Max	Min	Max
A	3.710	4.310	0.146	0.170
A1	0.510		0.020	
A2	3.200	3.600	0.126	0.142
B	0.380	0.570	0.015	0.022
B1	1.524 (BSC)		0.060 (BSC)	
C	0.204	0.360	0.008	0.014
D	9.000	9.400	0.354	0.370
E	6.200	6.600	0.244	0.260
E1	7.320	7.920	0.288	0.312
e	2.540 (BSC)		0.100 (BSC)	
L	3.000	3.600	0.118	0.142
E2	8.400	9.000	0.331	0.354



Fremont Micro Devices (SZ) Limited

#5-8, 10/F, Changhong Building, Ke-Ji Nan 12 Road, Nanshan District, Shenzhen, Guangdong 518057
Tel: (86 755) 86117811
Fax: (86 755) 86117810

Fremont Micro Devices (Hong Kong) Limited

#16, 16/F, Blk B, Veristrong Industrial Centre, 34-36 Au Pui Wan Street, Fotan, Shatin, Hong Kong
Tel: (852) 27811186
Fax: (852) 27811144

Fremont Micro Devices (USA), Inc.

42982 Osgood Road Fremont, CA 94539
Tel: (1-510) 668-1321
Fax: (1-510) 226-9918

Web Site: <http://www.fremontmicro.com/>

* Information furnished is believed to be accurate and reliable. However, Fremont Micro Devices, Incorporated (BVI) assumes no responsibility for the consequences of use of such information or for any infringement of patents of other rights of third parties which may result from its use. No license is granted by implication or otherwise under any patent rights of Fremont Micro Devices, Incorporated (BVI). Specifications mentioned in this publication are subject to change without notice. This publication supersedes and replaces all information previously supplied. Fremont Micro Devices, Incorporated (BVI) products are not authorized for use as critical components in life support devices or systems without express written approval of Fremont Micro Devices, Incorporated (BVI). The FMD logo is a registered trademark of Fremont Micro Devices, Incorporated (BVI). All other names are the property of their respective owners.