

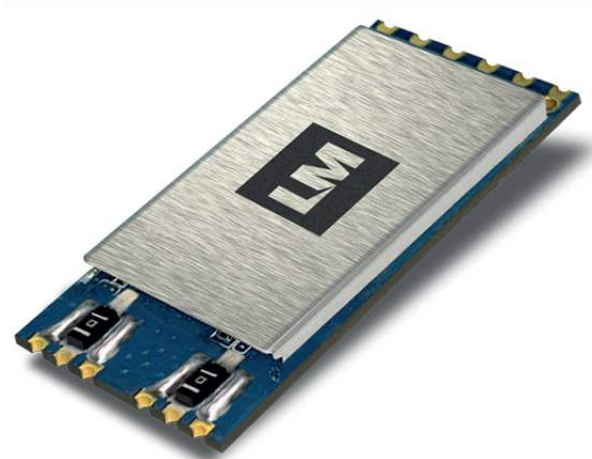

LM843 WiFi 802.11ac / Bluetooth® 5.0 2T2R Combi USB Module

XCVR SMT USB Module

Revised 24/JAN/2021
Datasheet Version 1.8
Ordering Options See last page

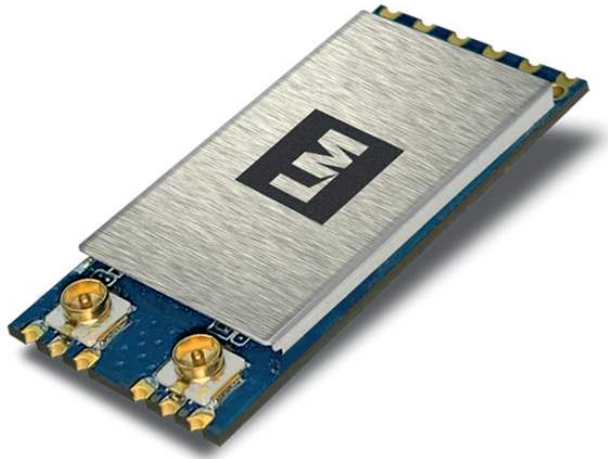

Features

- 802.11ac standard + MIMO on 5G
- 2T2R, Wave-2 Compliant + (2x2) MU-MIMO. MIMO offers extended bandwidth for reception and throughput
- USB 2.0 Maximum Throughput 480Mbps (58.7MBps)
- ISM Bands (2.4GHz or 5GHz)
- IEEE support: 802.11 a/ b/ g/ n/ ac/
- Cross Standard Connections
802.11n connection and/or connected to 802.11a/b/g devices
- Two options are available; 2x IPEX, or 2x RF Line Out
- Theoretical Maximum Bandwidths
 - 173.3 Mbps using 20MHz
 - 400. Mbps using 40MHz
 - 866.7Mbps using 80MHz
- Transmission Modulation 5MHz / 10MHz / 20MHz / 40MHz / 80MHz OFDM with BPSK, QPSK, 16QAM, 64QAM and 256QAM.
- Bluetooth® 5.0 Dual Mode
Support for simultaneous connections over LE and BR/EDR
- Enhanced BT/WiFi Coexistence Control to improve transmission quality in different profiles and support for multiple Low Energy positions (Sniff / Sniff Sub-rating)
- REACH / RoHS / Low Halogen compliant.

Overview

Our LM843 Series WiFi 802.11ac + Bluetooth® 5.0 (Dual Mode) Combination SMT Module, offers a wide range of solutions and can support 2-stream 802.11ac with Multi-user MIMO (Multiple-Input, Multiple-Output) connections, while operating under enhanced power management.

Released under BT5.0 the products hardware is compliant to Bluetooth® 5.0 and offers Dual Mode compatibility with; Classic; 2.1 / 3.0 / 3.0+HS using either BR/EDR radio's and Low Energy [LE] connections under Bluetooth® 4.0, 4.1, 4.2 & 5.0 Classic and LE can operate multiple connections simultaneously using the USB 2.0 interface, onboard management for maximising throughput while multiple connections are open under WiFi and/or Bluetooth®.

Certification

The LM843 series will have United States of America FCC and European CE certifications completed prior to release. Further countries will be added during the course of the products life and or by request. Our company has a wealth of experience and has certified products all over the world, with access to a global network of local representatives, enabling fast certification processing when requested. Please enquire with us for further details.





LM843 WiFi 802.11ac / Bluetooth® 5.0 2T2R Combi USB Module

XCVR SMT USB Module

General Specification

Wireless

Wireless Standards	WiFi: 802.11ac, a b g n Bluetooth®: • Class 1. Dual Mode: 5.0, v4.2, v4.0 • Classic 2.1, 3.0, 3.0HS, +EDR
Module Type	Host Controller Interface (HCI)
OS Compatibility	Android, Linux, Windows 7, Windows 10
Security	WiFi; WPA, WPA-PSK, WPA2, WPA2 -PSK and WEP (64bit & 128bit) Bluetooth®; Simple Paring
Network Architecture	WiFi; Ad hoc mode (Peer-to-Peer) and Infrastructure mode Software AP; WiFi Direct Bluetooth®; Pico Net; Scatter Net

Hardware

Chipset	Realtek
Antenna	2 x IPEX Antennas, or 2 x RF Line Out
Interfaces	USB 2.0 Maximum Throughput 480Mbps (58.7Mbps) / Host Controller Interface (HCI)

Physical Characteristics

Operating Temperature	-20°C to +60°C ambient temperature 5 to 90 % (non-condensing)		
Storage Temperature	-20°C to +70°C ambient temperature 5 to 90 % (non-condensing)		
Dimensions (L x W x H)	L: 25mm x W:12mm x H:2mm +/- 0.2 tolerance		
Weight	6.5g		
Certifications	FCC / CE. See our website for further updates.		
Compliance	RoHS, REACH and WEEE		
Warranty	2 Year Manufacturer RTB		
Power Supply	DC 3.3v		
Power Consumption	Input Voltage	Power Consumption	
	Minimum	3.135v	Minimum
	Typical	3.300v	Typical
	Maximum	3.465v	Maximum



LM843 WiFi 802.11ac / Bluetooth® 5.0 2T2R Combi USB Module
 XCVR SMT USB Module

General Specification (Continued)

RF Characteristics	<p>WiFi:</p> <p>802.11b: 11, 5.5, 2, 1 Mbps</p> <p>802.11g: 54, 48, 36, 24, 18, 12, 9, 6 Mbps</p> <p>802.11n: MCS0 to 7 for HT20MHz, MCS0 to 7 for HT40MHz</p> <p>802.11ac: MCS0 to 8 for HT20MHz, MCS0 to 9 for HT40MHz, NSS1 MCS0 to 9 for VHT80MH</p>
Data Transfer Rate	<p>Bluetooth®:</p> <p>Basic Rate up to 1Mbps, EDR up to 3Mbps</p> <p>Low Energy: LE 1M: 1Mbps</p> <p>LE Coded S=8: 125kbps,</p> <p>LE Coded S=2: 500kbps,</p> <p>LE 2M: 2Mbps</p>
Frequency	2.4GHz and 5GHz ISM Band
Modulation Method	<p>WiFi:</p> <p>CCK, DQPSK, DBPSK, BPSK, QPSK, 16QAM, 64QAM, 256QAM</p> <p>Bluetooth®:</p> <p>8DPSK, $\pi/4$ DQPSK, GFSKFSK</p>
Spread Spectrum	<p>WiFi:</p> <p>IEEE 802.11b: CCK (Complementary Code Keying)</p> <p>IEEE 802.11g/n/a/ac: OFDM (Orthogonal Frequency Division Multiplexing)</p> <p>Bluetooth®:</p> <p>FHSS (Frequency Hopping Spread Spectrum)</p>
Operating Channel	<p>WiFi (2.4GHz & 5GHz):</p> <p>11: (Ch. 1-11) – US (United States)</p> <p>13: (Ch. 1-13) – ETSI</p> <p>14: (Ch. 1-14) – TELEC</p> <p>Bluetooth® (2.4GHz):</p> <p>Ch. 0 to 78</p>



LM843 WiFi 802.11ac / Bluetooth® 5.0 2T2R Combi USB Module

XCVR SMT USB Module

General Specification (Continued)

RF Characteristics

Tx Output Power (Typical)	<p>WiFi;</p> <p>17dBm, EVM< 8% – 802.11b@CCK 11Mbps</p> <p>15dBm, EVM< -25dB – 802.11g@OFDM 54Mbps</p> <p>14dBm, EVM< -28dB – 802.11n@MCS7_HT20</p> <p>14dBm, EVM< -28dB – 802.11n@MCS7_HT40</p> <p>15dBm, EVM< -25dB – 802.11a@OFDM 54Mbps</p> <p>12dBm, EVM< -32dB – 802.11ac@NSS1 MCS9_BW80</p> <p>Bluetooth®:</p> <p>Maximum Max +8dBm</p>
---------------------------	--

Rx Sensitivity (Typical)	<p>WiFi;</p> <p><-76dBm – 802.11b@11Mbps</p> <p><-65dBm – 802.11g@54Mbps</p> <p><-64dBm – 802.11n@MCS7_BW20</p> <p><-61dBm – 802.11n@MCS7_BW40</p> <p><-51dBm – 802.11ac@NSS1_MCS9_BW80</p> <p>Bluetooth®:</p> <p><-85dBm, BER<0.01% –Basic rate @1Mbps</p> <p><-80dBm, BER<0.1% –Enhanced data rate @2,3Mbps</p> <p><-85dBm, BER<=-30.8% –Low Energy @1Mbps, 125kbps, 500kbps, 2Mbps</p>
--------------------------	--



LM843 WiFi 802.11ac / Bluetooth® 5.0 2T2R Combi USB Module

XCVR SMT USB Module

Pin Outs

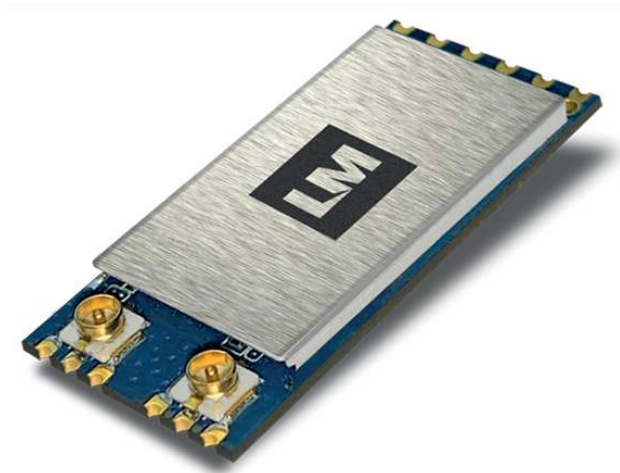
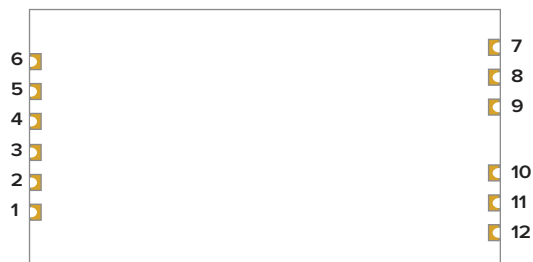

Pin Assignments

Pin	Signal	Type	Description
1	GPIO3 /WPS	Output	GPIO3. General Purpose Input/ Output Pin Shared with WPS Pin (Active Low).
2	VDD	Power	DC 3.3V
3	HSDM	I/O	USB 2.0 Transceiver Differential Pair
4	HSDP	I/O	USB 2.0 Transceiver Differential Pair
5	GND	-	Ground
6	GPIO8 /WL_LED	I/O	GPIO8. General Purpose Input / Output Pin / WL LED Pin (Active Low).
7	GND	-	Ground
8	RF_S0	RF	WLAN RF port (if not using IPEX connector)
9	GND	-	Ground
10	GND	-	Ground
11	RF_S1	RF	WLAN / BT RF port (if not using IPEX connector)
12	GND	-	Ground

LM843 WiFi 802.11ac / Bluetooth® 5.0 2T2R Combi USB Module
XCVR SMT USB Module

IPEX Connector Dimensions

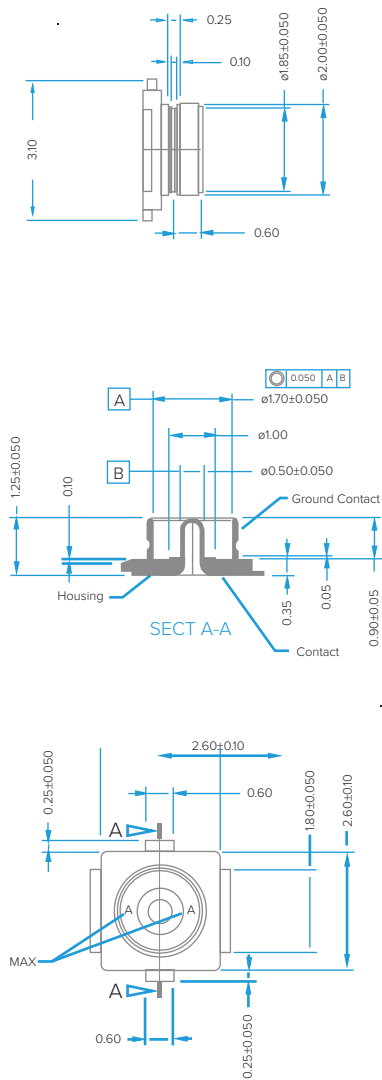

Physical Dimensions / PCB Footprint

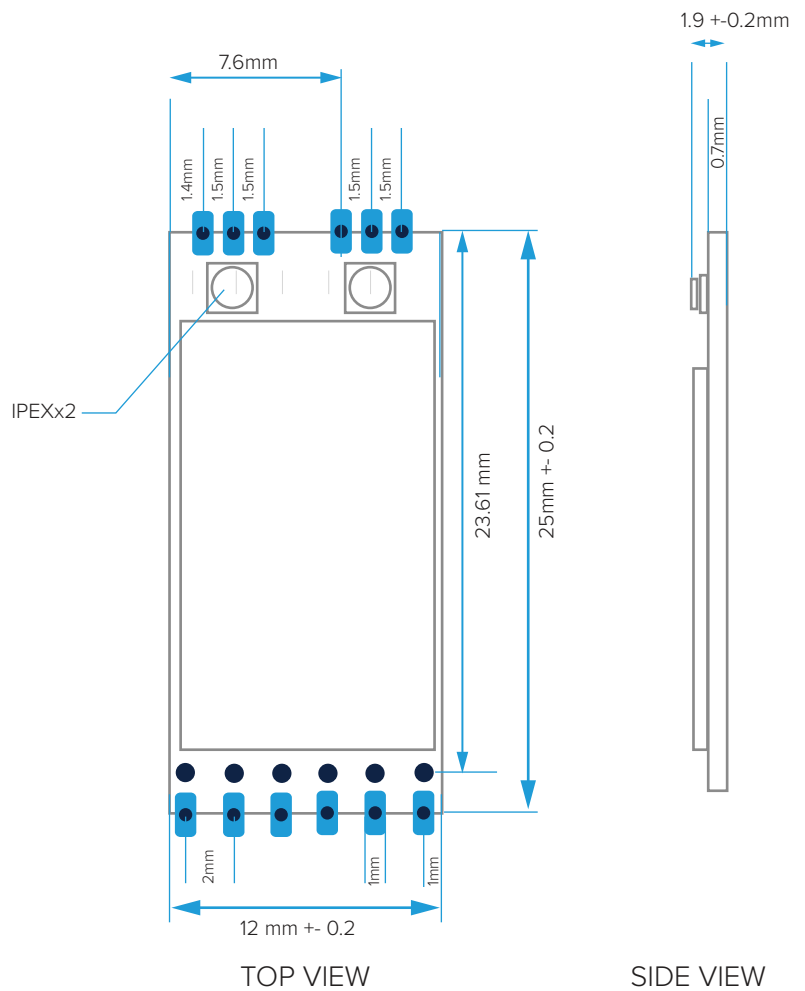

- The external circuit for WiFi activity LED (factory option)

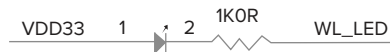

- The external circuit for WiFi activity WPS display

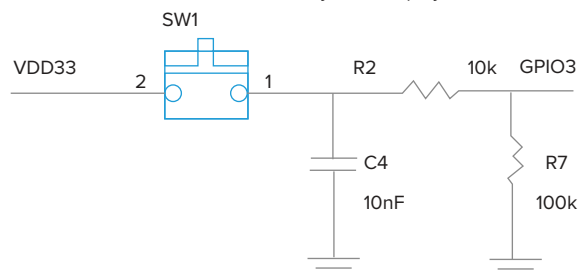

GPIO8 Pin Out
Option for WiFi activity LED (factory option)

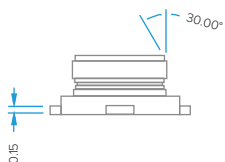

LM843 WiFi 802.11ac / Bluetooth® 5.0 2T2R Combi USB Module
 XCVR SMT USB Module

Antenna Output Options

RF Output is offered as either 2x IPEX or 2x Half Hole Terminal

Neither of these modules have an antenna, for certification purposes we have certified these using an IPEX 3dBi IPEX to SMA Antenna, this enables your design to use any antenna up to a maximum of 3dBi Gain, above this level and our certification will not be valid.

We offer free design in support, either to assist you or your third-party to ensure the correct placement and/or advice on how best an antenna should be supported.

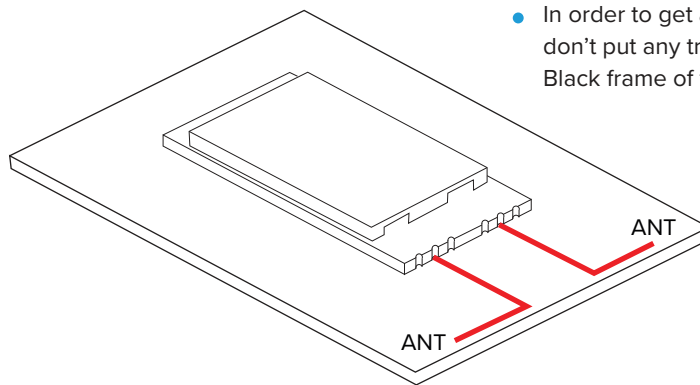
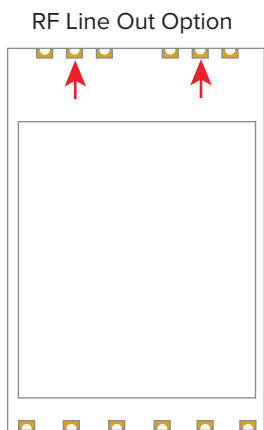

- In order to get a better RF performance, please don't put any trace or copper plane under the Black frame of the module.

- Please have the impedance of feed lines to be 50 ohms from the RF output pin to Antenna.

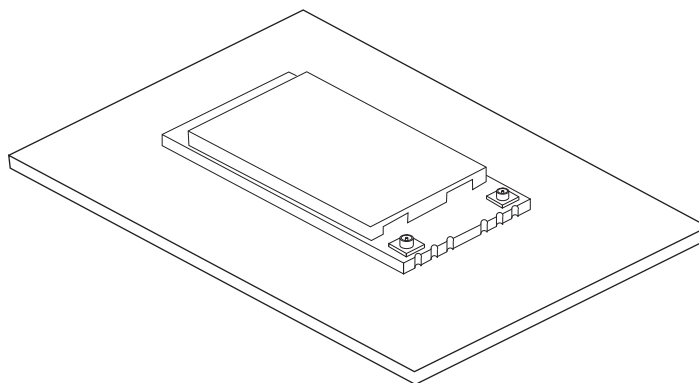
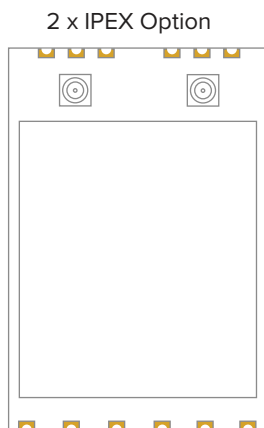

LM843 WiFi 802.11ac / Bluetooth® 5.0 2T2R Combi USB Module

XCVR SMT USB Module

XCVR Block Diagram (2 x RF Half Hole Line Out)

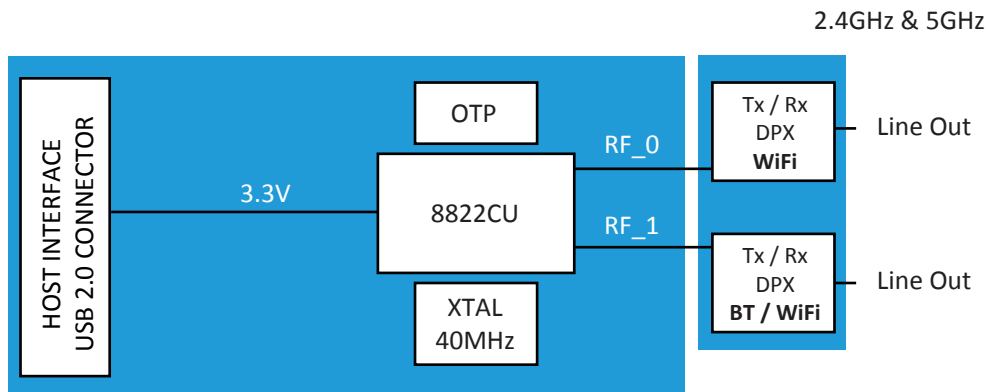

XCVR Block Diagram (2 x IPEX Antennas)

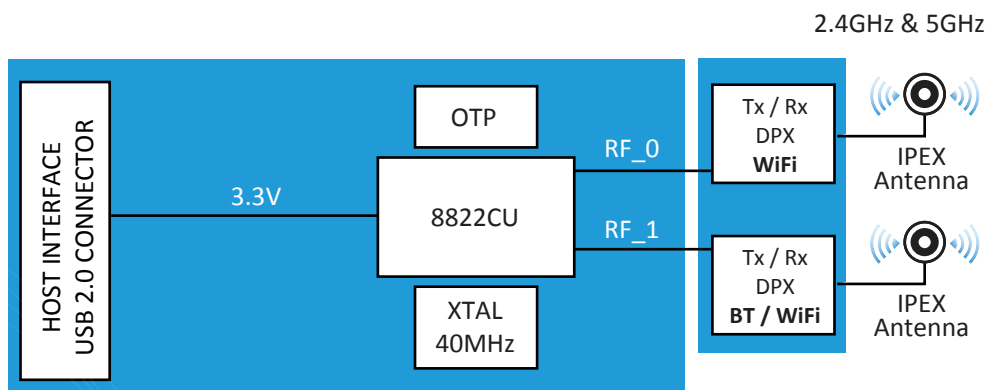

Extended Temperature Range

Our SMT Module Low Temperature Product Update is changing a 0c rated product into a -20c rated product.

In this update we ensure all items in the BOM except the main IC, are components rated at -40c, the Realtek IC is made from material tested and approved for -30c, rated at 0 due to a range of factors, such as low demand for -40 compliance, cost of -40c rated material is approved and tested at -60c and is expensive to manage.

Our products undergo an intensive test regime within which we temperature test and conduct a range of functions via our test program continuously for 72 hours at -40c, -20x 0c and 20c. If during this test we see no gradual drop off in performance and any initial drop off is less than 15% we will then pass the product as approved to support -20c.

We provide warranty on all LM843 -20c products for 2 years.

LM843 WiFi 802.11ac / Bluetooth® 5.0 2T2R Combi USB Module

XCVR SMT USB Module

PCB Drying Conditions

Please refer below to the conditions for drying before the solder reflow processes. (Extracted from IPC/JEDEC J-STD-033B.1)

1. If the system PCBA is double side design please reflow the side without this module first.
2. Don't let the solder machine temperature over 250 °C or follow solder paste vender's recommended temperature.
3. The Ramp-up temperature speed is 1~4 °C per second, the Ramp-down temperature speed is 1~4 °C per second.
4. This temperature reflow chart is for reference only, it depends on the manufacturing machine's characters requirement.

Bake @ 125 °C		Bake @ 90 °C		Bake @ 40 °C	
Exceeding floor Life by > 72h	Exceeding floor Life by ≤ 72h	Exceeding floor Life by > 72h	Exceeding floor Life by ≤ 72h	Exceeding floor Life by > 72h	Exceeding floor Life by ≤ 72h
9 hours	7 hours	33 hours	23 hours	13 days	9 days

Soldering Reflow Chart

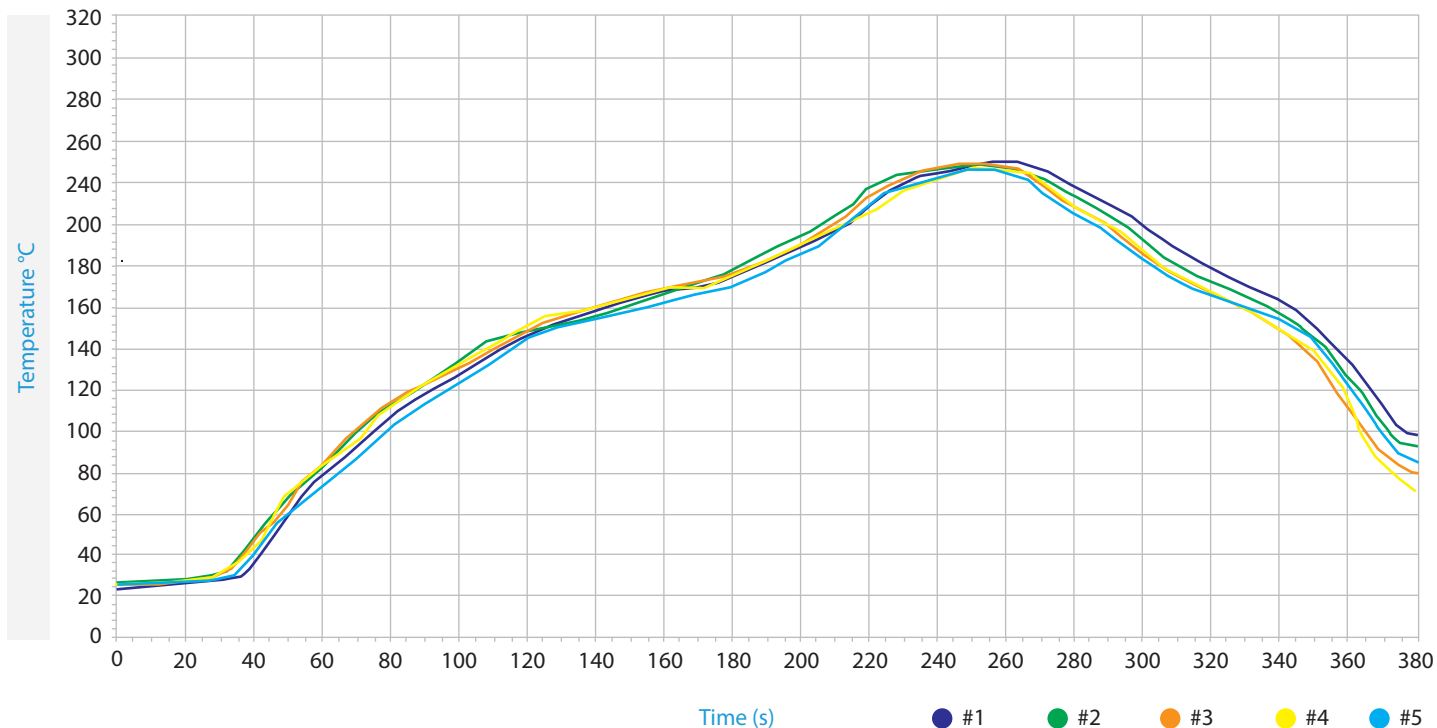

Name	Zone 1	Zone 2	Zone 3	Zone 4	Zone 5	Zone 6	Zone 7	Zone 8
Max	180.0	180.0	170.0	170.0	180.0	210.0	260.0	245.0
Min	180.0	180.0	170.0	170.0	180.0	210.0	260.0	245.0
Length	1.0	1.0	1.0	1.0	1.0	1.0	1.0	1.0

Probe	Liquidus Line		Maximum / Minimum		Slope	
	Rising 110.00-190.00	Above 230.0	Max	Min	Positive	Negative
#1	119.00	47.50	245.50	27.30	2.56	-1.69
#2	116.50	49.00	247.10	27.70	2.69	-1.60
#3	116.00	46.50	245.80	29.30	2.04	-1.57
#4	117.00	46.50	244.90	29.20	2.60	-1.31
#5	119.50	50.00	248.10	29.60	2.44	-1.64

LM843 WiFi 802.11ac / Bluetooth® 5.0 2T2R Combi USB Module

XCVR SMT USB Module

Packaging for Tape & Reel / Tray

The Tape & Reel / Tray are inserted into an anti-static vacuum bag with a Humidity Indicator Card and Drying Agent. On the outside of the vacuum bag are MSL (Moisture Sensitivity Levels), MPN and an Anti-Static Labels.

Tape & Reel

Reels are placed within a vacuum bag.

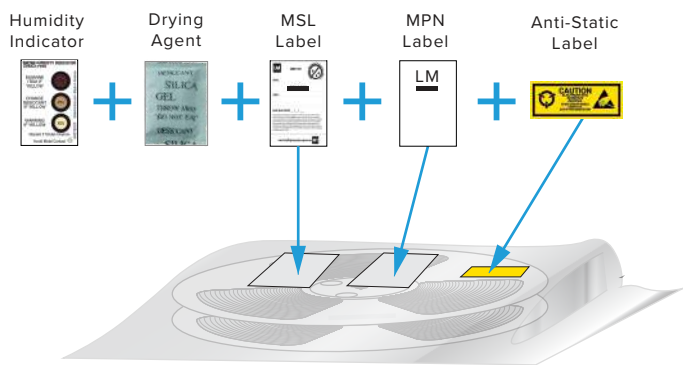
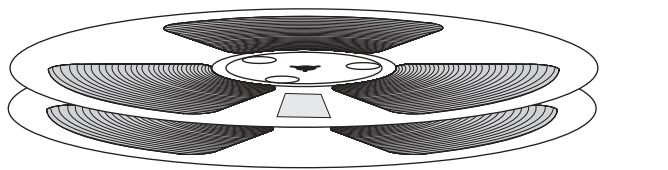

Vacuum bag.

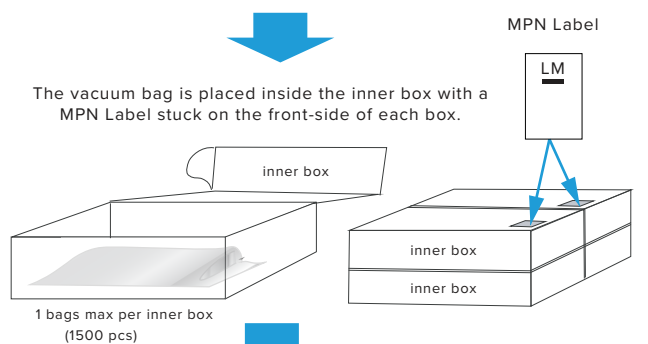

1 bags max per inner box (1500 pcs)

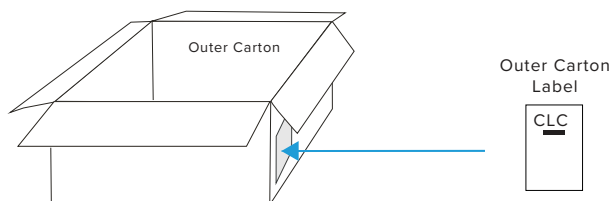

Each Outer Carton contain 5 inner boxes max (7500 pcs)

Tray

Trays are stacked with an empty tray on the top and placed within a vacuum bag.

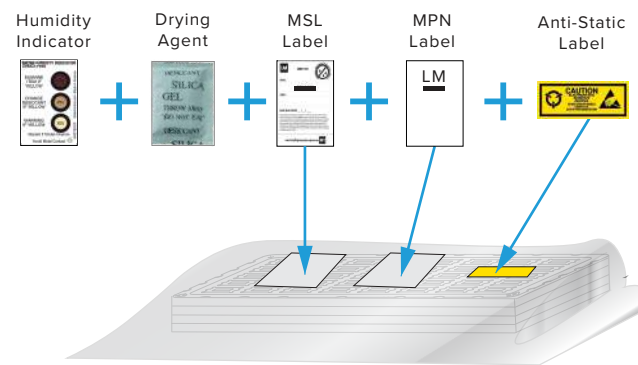
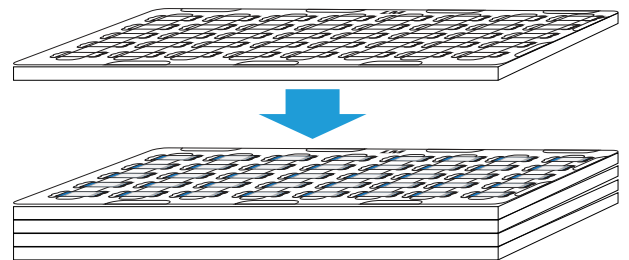

Vacuum bag.

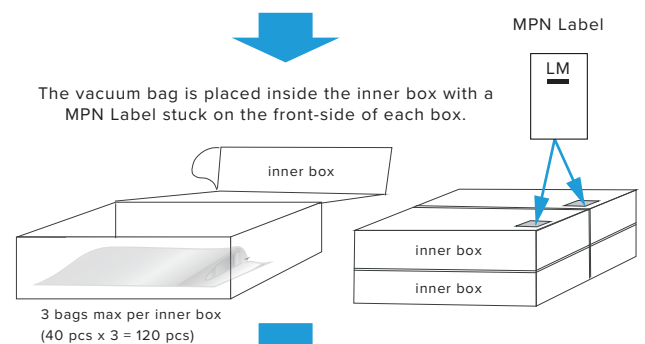

3 bags max per inner box (40 pcs x 3 = 120 pcs)

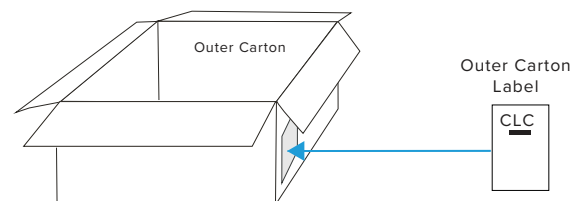

Each Outer Carton contain 8 inner boxes max (120 pcs x 8 = 960 pcs)



LM843 WiFi 802.11ac / Bluetooth® 5.0 2T2R Combi USB Module

XCVR SMT USB Module

Datasheet Version Notes

v0.2	27 SEP 2019	Revised information throughout.
v0.3	03 OCT 2019	Revised information throughout.
v1.0	29 NOV2019	Win 10 removal. Antenna Option diagrams added.
v1.1	24 FEB 2020	New image.
v1.2	17 MAR 2020	Antenna Option Revisions.
v1.3	11 MAY 2020	Physical Dimensions and Diagram updated.
v1.4	15 MAY 2020	Removed PCB Footprint, appended PCB Footprint title to Physical Dimensions illustration.
v1.5	30 JUL 2020	Android, Linux, Windows 7, Windows 10.
v1.6	10 AUG 2020	Flip Block Diagram layout.
v1.7	21 OCT 2020	Amended certified antenna gain.
v1.8	24 JAN 2021	Datasheet branding update.



LM843 WiFi 802.11ac / Bluetooth® 5.0 2T2R Combi USB Module
XCVR SMT USB Module

Ordering Options



MFT Part No.	Product Description	Invoice Description	RF Bands	Packaging	Expected EOL
843-8430	MOD 802.11ac BT5.0 USB 2T2R IPEX PCS/SP		ETSI	S/SP	2029
843-8431	MOD 802.11ac BT5.0 USB 2T2R IPEX PCS/SP		US	S/SP	2029
843-8432	MOD 802.11ac BT5.0 USB 2T2R IPEX TRAY		ETSI	TRAY	2029
843-8433	MOD 802.11ac BT5.0 USB 2T2R IPEX TRAY		US	TRAY	2029
843-8434	MOD 802.11ac BT5.0 USB 2T2R IPEX T&R		ETSI	T&R	2029
843-8435	MOD 802.11ac BT5.0 USB 2T2R IPEX T&R		US	T&R	2029



843-8436	MOD 802.11ac BT5.0 USB 2T2R RF_LINE PCS/SP		ETSI	S/SP	2029
843-8437	MOD 802.11ac BT5.0 USB 2T2R RF_LINE PCS/SP		US	S/SP	2029
843-8438	MOD 802.11ac BT5.0 USB 2T2R RF_LINE TRAY		ETSI	TRAY	2029
843-8439	MOD 802.11ac BT5.0 USB 2T2R RF_LINE TRAY		US	TRAY	2029
843-8440	MOD 802.11ac BT5.0 USB 2T2R RF_LINE T&R		ETSI	T&R	2029
843-8441	MOD 802.11ac BT5.0 USB 2T2R RF_LINE T&R		US	T&R	2029

- See LM240 IPEX Cable for SMA Antennas - <https://www.lm-technologies.com/product/ipex-to-rp-sma-male-jack-cable-100mm-lm240/>
- Product User Guides, Manuals and Configuration Software can be downloaded via our website - <http://www.lm-technologies.com/downloads>

LM843 WiFi 802.11ac / Bluetooth® 5.0 2T2R Combi USB Module
XCVR SMT USB Module

Tray Packaging

Tray Dimensions

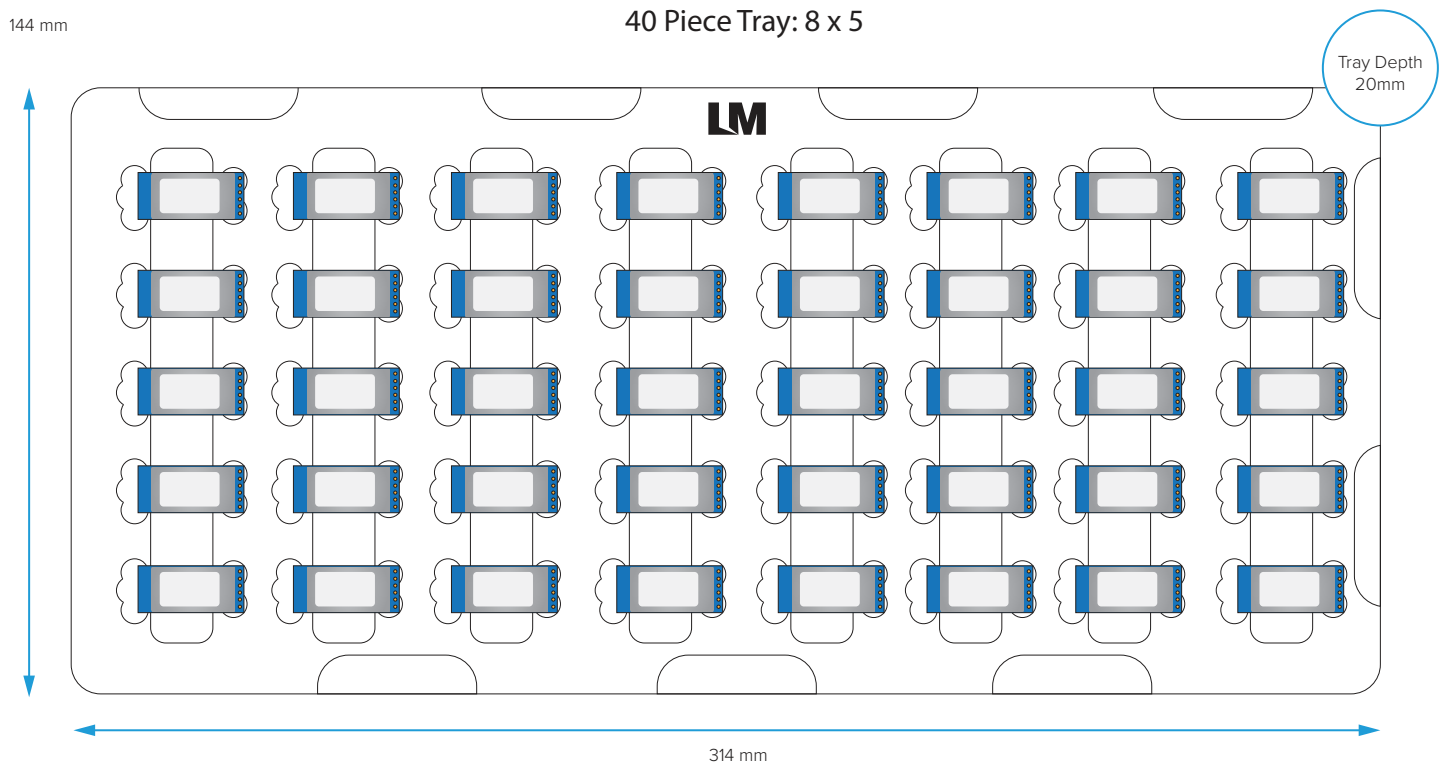

Quantities

- 40 modules per Tray
- 3 Trays per Inner Box
- 120 modules per Inner Box
- 8 Inner Boxes per Outer Carton
- 960 modules per Outer Carton

Notes

- Anti-Static PS Tray, Black.
- Material Thickness: 1mm
- Height of Tray: 20mm
- Carton Dimensions (L x W x H):
340mm x 290mm x 385mm

LM843 WiFi 802.11ac / Bluetooth® 5.0 2T2R Combi USB Module

XCVR SMT USB Module

Tape and Reel Packaging

Tape Dimensions

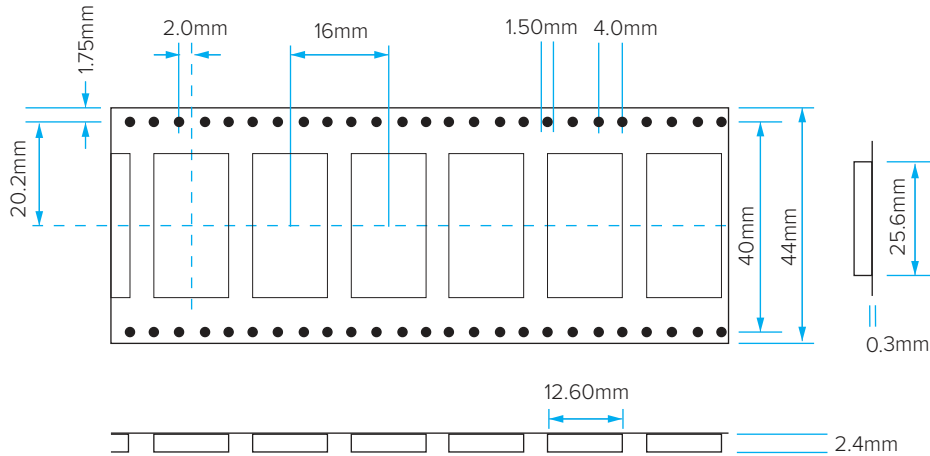

Reel Dimensions

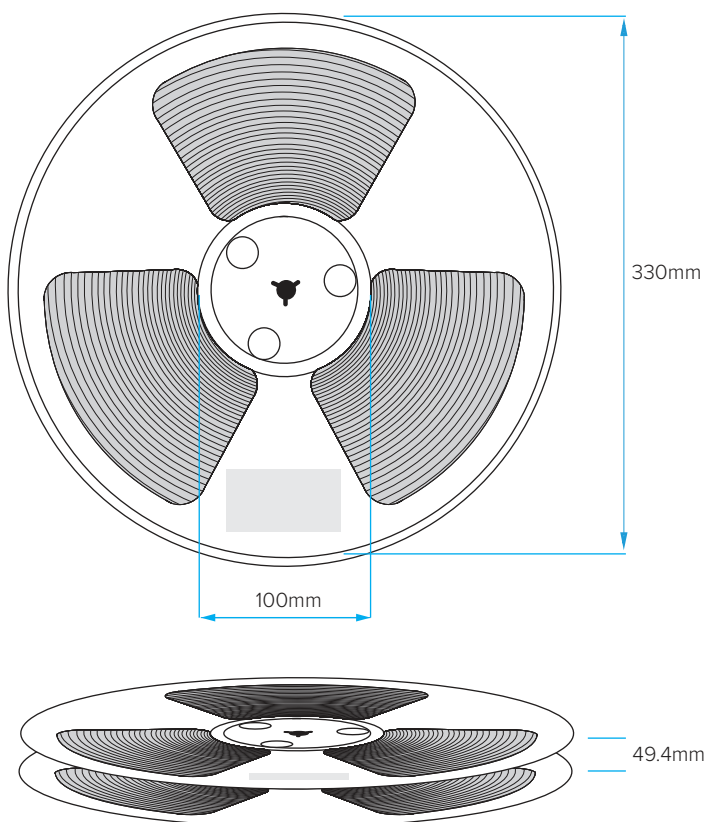

Quantities

- 1500 modules per Tape & Reel
- 1 Tape & Reel per Inner Box
- 5 Inner Boxes per Outer Carton
- 7500 modules per Outer Carton

Notes

- Inner Box Dimensions (L x W x H):
360mm x 360mm x 60mm
- Outer Carton Dimensions (L x W x H):
395mm x 360mm x 305mm