

Evaluation board for automotive-grade ESD protection

Data brief

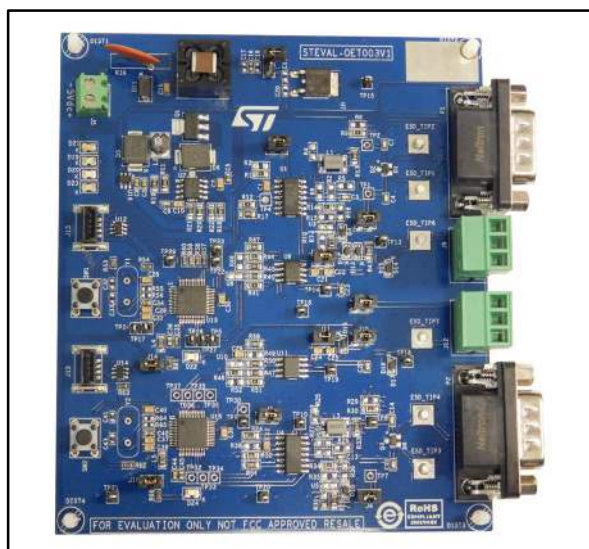

Description

This demonstration tool is designed to provide an easy way to evaluate the robustness of ESD diodes developed for the automotive environment. It is based on a master-slave structure on the same board using two STM8AF528.

The microcontrollers communicate with each other via a communication loop based on LIN/CAN protocol. Communication flow status is indicated by four onboard LEDs. The LIN and CAN bus interfaces use four transceivers and are supplied by the step-up converter.

Features

- Input voltage 5 V
- 12 V output, step-up converter for transceiver supply voltage
- LIN transceiver
- CAN transceiver
- Automotive-grade ESD protection
- IEC61000-4-2 compatibility

Schematics

Figure 1: Schematics power section

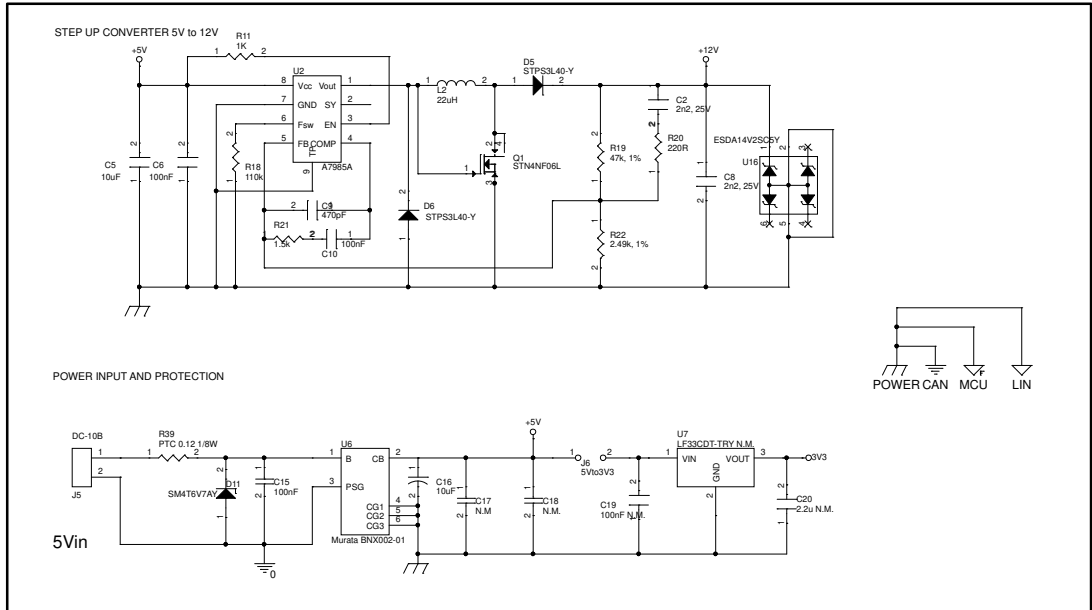

Figure 2: Schematics LIN section

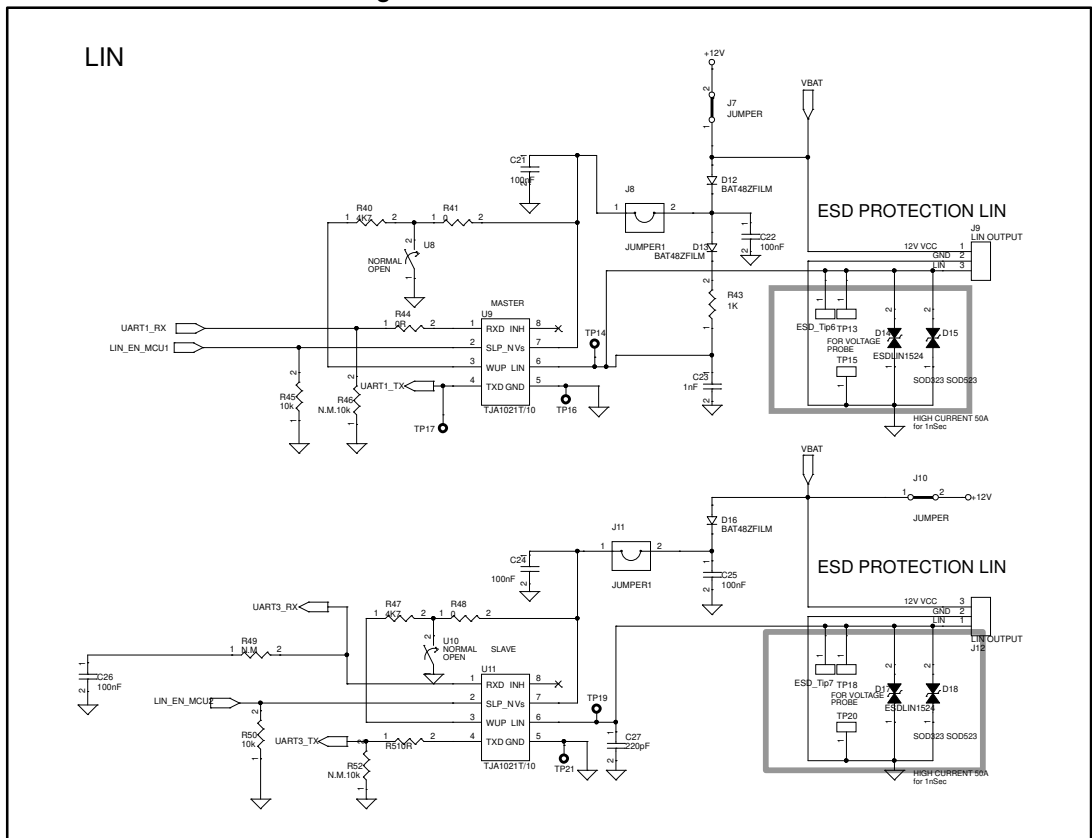

Figure 3: Schematics CAN section

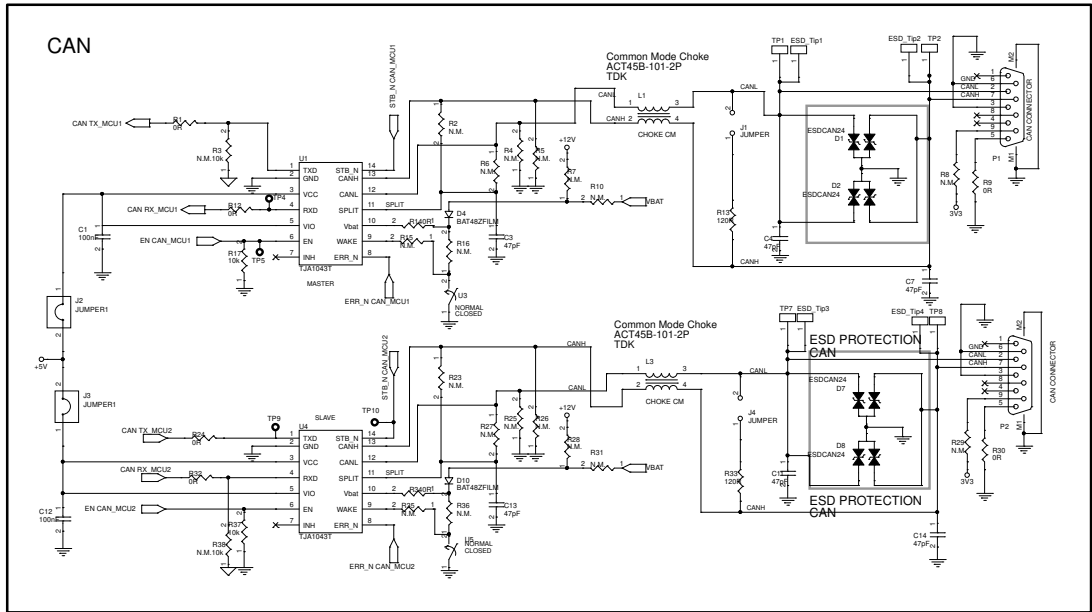

Figure 4: Schematics master node

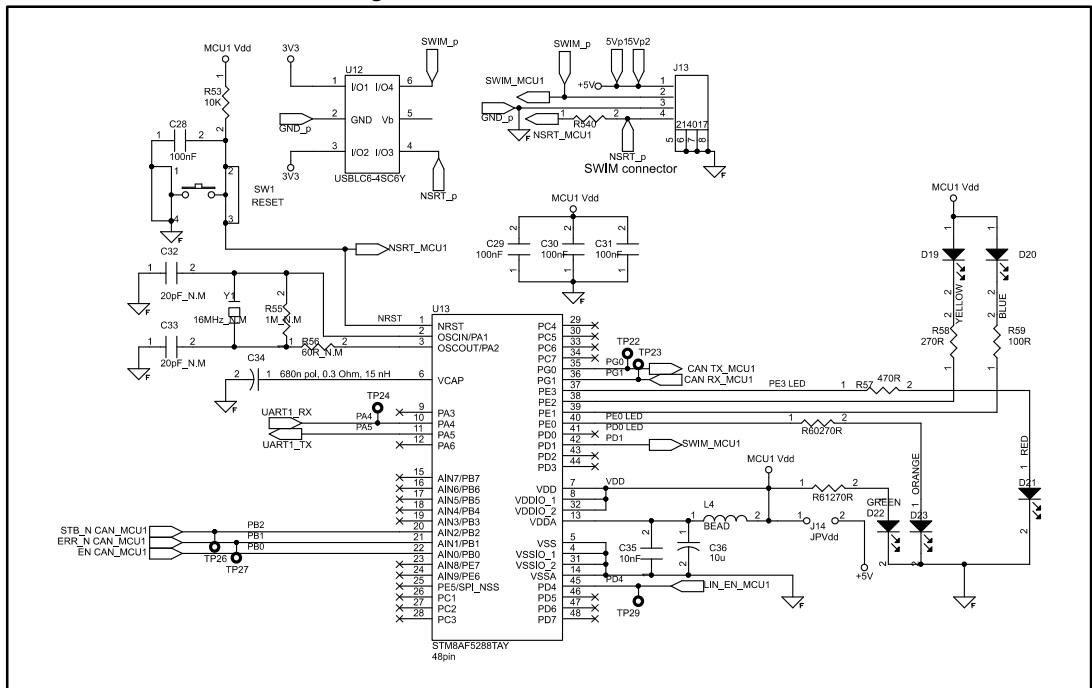
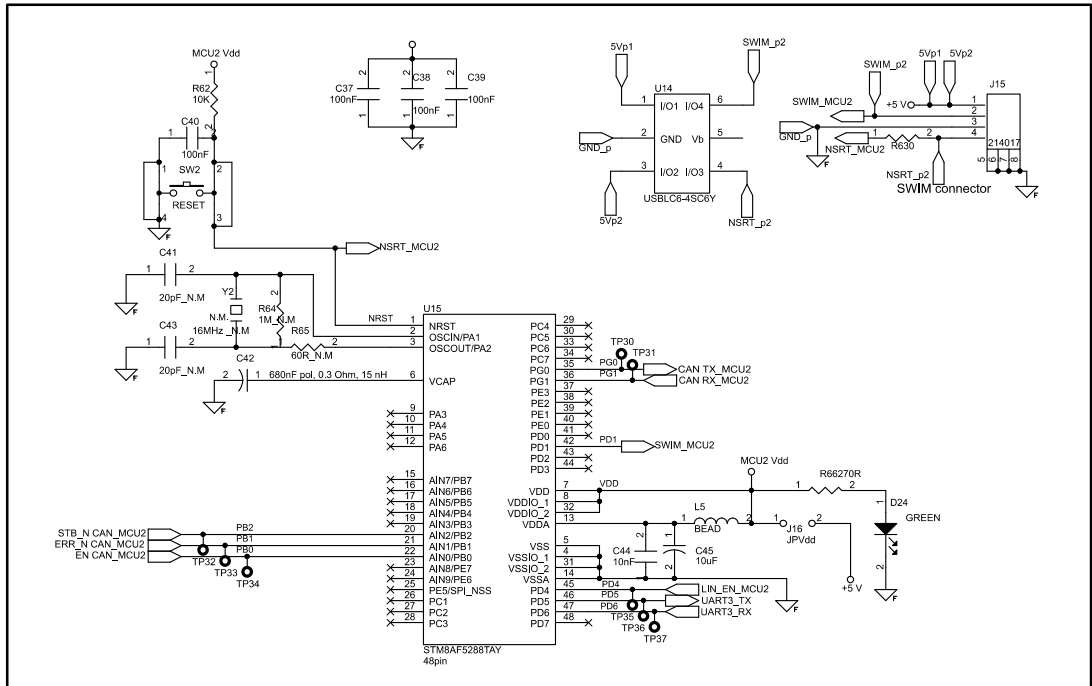

Figure 5: Schematics slave node



Bill of materials

Table 1: STEVAL-OET003V1 bill of materials

Item	Q.ty	Reference	Value	Description	Part Number	Manufacturer
1	1	C27	220pF, 100V ±5%	Ceramic C0G - automotive grade	CGA3E2C0G2A221 J080AA	TDK Corporation
2	1	C23	1nF, 100V ±5%	Ceramic C0G - automotive grade	CGA3EANP02A102 J080AA	TDK Corporation
3	18	C1,C6,C10,C12,C15,C 21,C22,C24,C25,C26, C28,C29,C30,C31,C37, C38,C39,C40	100nF, 100V ±10%	Ceramic X7R - automotive grade	ESD51C104K4T2A- 24	AVX Corporation
4	6	C3,C4,C7,C11,C13,C1 4	47pF, 100V ±10%	Ceramic COG - automotive grade	06031A470K4T2A	AVX Corporation
5	4	C32,C33,C41,C43	20pF, 50V ±5%	Ceramic COG - not mounted	CL10C200JB81PNC	Samsung Electro- Mechanics America, Inc
6	2	C34,C42	680nF, 16V ±10% (0.3Ω, 15nH)	680nF,10%,16V ,TAN-B	CGA3E1X7R1E684 M080AC	TDK
7	2	C35,C44	10nF, 50V ±10%	Ceramic X7R - automotive grade		TDK Corporation
8	4	C5,C16,C36,C45	10μF, 10V ±20%	Ceramic X5R - automotive grade	LMK107BBJ106MA HT	Taiyo Yuden
9	1	C19	100nF ±10%	Ceramic X5R - not mounted	ANY	ANY
10	1	C20	2.2μF, 10V ±10%	Ceramic X5R - not mounted	ANY	ANY
11	2	C2,C8	2n2, 50V ±10%	Ceramic X7R - automotive grade mounted	GCM188R71H222K A37D	Murata Electronics North America
12	2	C17,C18	N.M.	Ceramic X7R - not mounted	ANY	ANY
13	1	C9	470pF, ±5%	Ceramic COG - automotive grade	CGA3E2C0G1H471 J080AA	TDK Corporation
14	5	D4,D10,D12,D13,D16	40V, 350mA	Small signal Schottky diode	BAT48JFILM	ST
15	2	D15,D18	30kV	Transil for ESD protection - not mounted	ESDLIN1524BJ	ST
16	2	D14,D17		not mounted	ESDLINxx	

Item	Q.ty	Reference	Value	Description	Part Number	Manufacturer
17		D1,D7			ESDCAN02-2BWY	ST
18	2		30kV	Automotive dual-line Transil™ for ESD protection - provided in antistatic bag	ESDCAN24-2BLY	ST
19				provided in antistatic bag	ESDCAN03-2BWY	ST
20				provided in antistatic bag	ESDCAN01-2BLY	ST
21	4	D2,D8		Automotive dual-line Transil™ for ESD protection	ESDCANxx	
22	1	D21	5V reverse	SMD LED - red	RED LED	OSRAM
23	1	D20	5V reverse	SMD LED - blue	BLUE LED	Lite-On
24	1	D19	5V reverse	SMD LED - yellow	YELLOW LED	OSRAM
25	2	D22,D24	5V reverse	SMD LED - green	GREEN LED	Lite-On
26	1	D23	5V reverse	SMD LED - orange	ORANGE LED	Lite-On
27	1	D11	5V	Transil™ Unidirectional	SM4T6V7AY	ST
28	2	D5,D6	3A,40V	Schottky Diode	STPS3L40-Y	ST
29	2	J9,J12	CONN3, 400V	3way PCB terminal block	MKDSN 1.5/3-ST-3,81	Phoenix Contact
30	9	J1,J2,J3,J4,J6,J7,J8,J10,J11	STRIPLINE, 25V	2way single row STRIP Line (male) 2,54mm pitch for JUMPER		ANY
31	15	Jumper		JUMPER SOCKET	AKST/Z Black	ASSMAN N WSW
32	2	J13,J15	SWIM, 5V	SWIM CONNECTOR	214017	ERNI
33	1	J5	CONN, 5V	INPUT CONNECTOR	DC10B	CLIFF ELECTRONIC COMPONENTS
34	2	L1,L3		Common Mode Choke	ACT45B-101-2P-TL003	TDK
35	2	L4,L5	BEAD, 5V	BEED INDUCTOR	BMB2A0120AN4	TE Connectivity
36	1	L2	22µH, 1A ±20%	SMD Power Inductor	732 773 220	WE

Item	Q.ty	Reference	Value	Description	Part Number	Manufacturer
37	2	P1,P2		DB9 MALE CONNECTOR RIGHT ANGLE	6E17-C009P-AJ121	Amphenol
38	1	Q1		Power MOSFET	STN4NF06L	ST
39	12	R1,R7,R9,R12,R14,R24,R28,R30,R32,R34,R44,R51	0 Ω \pm 1%	Resistor	ANY	ANY
40	13	R8,R10,R15,R16,R23,R25,R26,R27,R29,R31,R35,R36,R49	not mounted \pm 1%	Resistor - not mounted	ANY	ANY
41	4	R3,R38,R46,R52	N.M.10k 1/8W \pm 1%	Resistor - not mounted	ANY	ANY
42	2	R11,R43	1K 1/8W \pm 1%	Resistor	ANY	ANY
43	2	R13,R33	120 1/8W \pm 1%	Resistor	ANY	ANY
44	2	R40,R47	4K7 1/8W \pm 1%	Resistor	ANY	ANY
45	6	R17,R37,R45,R50,R67;R68	10K 1/8W \pm 1%	Resistor	ANY	ANY
46	2	R3,R20	120R 1/8W \pm 1%	Resistor	ANY	ANY
47	2	R51,R40	60R 1/8W \pm 1%	Resistor	ANY	ANY
48	2	R55,R64	1M 1/8W \pm 1%	Resistor - not mounted	ANY	ANY
49	2	R53,R62	10K 1/8W \pm 1%	Resistor	ANY	ANY
50	1	R19	47k 1/8W \pm 1%	Resistor	ANY	ANY
51	4	R41,R48,R54,R63	0 1/8W \pm 1%	Resistor	ANY	ANY
52	2	R56,R65	57 1/8W \pm 1%	Resistor - not mounted	ANY	ANY
53	1	R57	470 1/8W \pm 1%	Resistor	ANY	ANY
54	4	R58,R60,R61,R66	270 1/8W \pm 1%	Resistor	ANY	ANY
55	1	R59	100 1/8W \pm 1%	Resistor	ANY	ANY
56	1	R22	2.49k 1/8W \pm 1%	Resistor	ERJ-6ENF2491V	Panasonic Electronic Components
57	1	R39	0.15R \pm 20%	THERMISTOR PTC 0.15 OHM	PTGL14ARR15M1B 51B0	Murata Electronics North America

Item	Q.ty	Reference	Value	Description	Part Number	Manufacturer
58	1	R18	110k 1/8W ±1%	Resistor	ANY	ANY
59	1	R21	1.5k 1/8W ±1%	Resistor	ANY	ANY
60	1	R20	220R 1/8W ±1%	Resistor	ANY	ANY
61	1	SW1,SW2		RESET MICRO SWITCH	1825910-6	TE Connectivity
62	22	TP5,TP8,TP9,TP10,TP11,TP12,TP13,TP14,TP15,TP16,TP17,TP18,TP19,TP20,TP21,TP22,TP23,TP24,TP25,TP26,TP27, TP28		PCB Test point PAD	200-203	RS
63	2	U1,U4	TJA1043T	CAN transceiver	TJA1043T,118	NXP Semiconductors
64	2	U7,U11	TJA1021T	LIN transceiver	TJA1021T/10/C,118	NXP Semiconductors
65	4	U3,U5,U8,U10		MICRO SWITCH - not mounted		smr0805CC
66	2	U13,U15		8-bit Microcontroller	STM8AF5288TAY	ST
67	1	U7		Voltage regulator	LF33CDT-TRY	ST
68	1	U6		Line filter	BNX002-01	Murata
69	1	U2		Buck-boost IC	A7985A	ST
70	2	U12,U14		ESD protection	USBLC6-4SC6Y	ST
71	1	U16		ESD protection	ESDA14V2SC5Y	ST
72	2	Y1,Y2	16MHz (with socket)	Crystal,16M, 20PF,20PPM, -10~60 degree, DIP, HC-49S - not mounted	HC-49S-B20QTA-16.0000	JFVNY
73	4	Dist1,Dist2,Dist3,Dist4		15mm	LCBSBM-10-01A2	RICHCO
74	6	ESD_TP1,ESD_TP2,ESD_TP3,ESD_TP4,ESD_TP6,ESD_TP7		Test Terminal	31100080005	Elettro components

Revision history

Table 2: Document revision history

Date	Version	Changes
26-Aug-2016	1	Initial release.

IMPORTANT NOTICE – PLEASE READ CAREFULLY

STMicroelectronics NV and its subsidiaries ("ST") reserve the right to make changes, corrections, enhancements, modifications, and improvements to ST products and/or to this document at any time without notice. Purchasers should obtain the latest relevant information on ST products before placing orders. ST products are sold pursuant to ST's terms and conditions of sale in place at the time of order acknowledgement.

Purchasers are solely responsible for the choice, selection, and use of ST products and ST assumes no liability for application assistance or the design of Purchasers' products.

No license, express or implied, to any intellectual property right is granted by ST herein.

Resale of ST products with provisions different from the information set forth herein shall void any warranty granted by ST for such product.

ST and the ST logo are trademarks of ST. All other product or service names are the property of their respective owners.

Information in this document supersedes and replaces information previously supplied in any prior versions of this document.

© 2016 STMicroelectronics – All rights reserved