

The engineer's choice

**ebmpapst**

# 412 JHHU

## INDEX

<b>1</b>	<b>General</b> .....	<b>3</b>
<b>2</b>	<b>Mechanics</b> .....	<b>3</b>
2.1	General .....	3
2.2	Connections .....	3
<b>3</b>	<b>Operating Data</b> .....	<b>4</b>
3.1	Operating Data - Electrical Interface - Input .....	4
3.2	Electrical Operating Data .....	5
3.3	Operating Data - Electrical Interface -Output .....	5
3.4	Electrical Features .....	5
3.5	Aerodynamic .....	7
3.6	Sound Data .....	7
<b>4</b>	<b>Environment</b> .....	<b>7</b>
4.1	General .....	7
4.2	Climatic requirements*) .....	7
<b>5</b>	<b>Safety</b> .....	<b>9</b>
5.1	Electrical Safety .....	9
5.2	Approval Tests .....	9
<b>6</b>	<b>Reliability</b> .....	<b>9</b>
6.1	General .....	9

## 1 General

Fan type	Fan	
Rotational direction looking at rotor	counterclockwise	
Airflow direction	Air outlet over struts	
Bearing system	Ball bearing	
Mounting position	any	

## 2 Mechanics

### 2.1 General

Width	40,0 mm	
Height	40,0 mm	
Depth	25,0 mm	
Weight	0,050 kg	
Housing material	Plastic	
Impeller material	Plastic	
Max. torque when mounted across both mounting flanges	wire outlet corner: 60 Ncm remaining corners: 60 Ncm	
Screw size	ISO 4762 - M3 degreased, without an additional brace and without washer	

### 2.2 Connections

Electrical connection	Wires	
Length of lead wire	310 mm	
Tolerance	+ - 10,0 mm	
Wire gauge (AWG)	26	
Insulation diameter	1,35 mm	

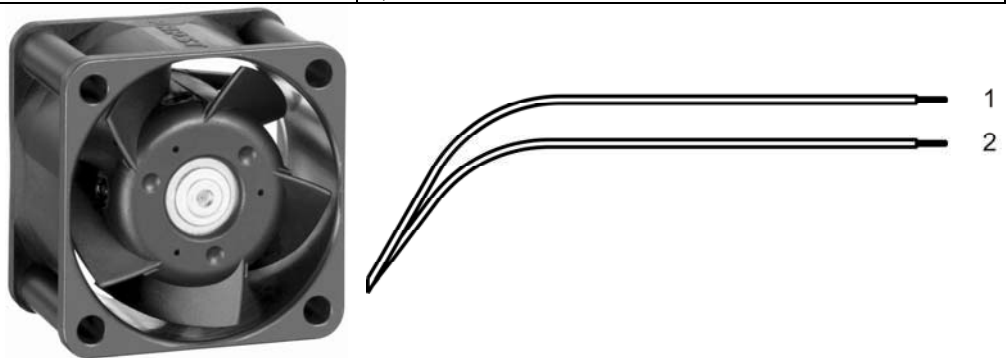

	Colour	Operation
Wire 1	red	+ UB
Wire 2	blue	- GND

**3 Operating Data**

**3.1 Operating Data - Electrical Interface - Input**

Control input	None
---------------	------

### 3.2 Electrical Operating Data

Measurement conditions: Normal air density = 1,2 kg/m<sup>3</sup>; Temperature 23°C +/- 3°C; Motor axis horizontal; warm-up time before measuring 5 minutes (unless otherwise specified). In the intake and outlet area should not be any solid obstruction within 0,5 m.

$\Delta p = 0$ : corresp. to free air flow (see section 3.5)  
I: corresp. to arithm. mean current value

Features	Condition	Symbol	Values		
Voltage range	$\Delta p = 0$	U	8,0 V		13,5 V
Nominal voltage	$\Delta p = 0$	$U_N$		12,0 V	
Power consumption	$\Delta p = 0$	P	1,5 W	3,2 W	4,2 W
Tolerance	0001		+/- 20,0 %	+/- 20,0 %	+/- 20,0 %
Current consumption	$\Delta p = 0$	I	190 mA	270 mA	310 mA
Tolerance	0001		+/- 20,0 %	+/- 20,0 %	+/- 20,0 %
Speed	$\Delta p = 0$	n	8.500 1/min	13.000 1/min	13.800 1/min
Tolerance	0001		+/- 15,0 %	+ 10 % - 15 %	+/- 15,0 %
Starting current consumption				2.100 mA	

### 3.3 Operating Data - Electrical Interface -Output

Tacho type	None
Alarm type	None

### 3.4 Electrical Features

Electronic function	None
Reversed polarity protection	Rectifying diode
Max. residual current at $U_N$	IF <= 50 $\mu$ A
Locked rotor protection	Auto restart
Locked rotor current at $U_N$	approx. 2.100 mA
Clock signal t3/t4 at locked rotor	Typical: 0,16 s / 1,0 s t3: 0,05 s... 0,37 s t4: 0,34 s... 2,2 s

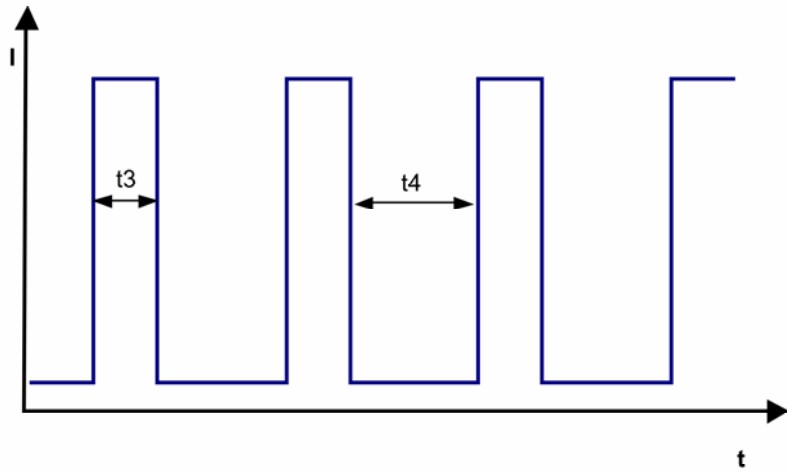

### 3.5 Aerodynamic

Measurement conditions: Measured with a double chamber intake rig acc. to DIN EN ISO 5801.  
Normal air density = 1,2 kg/m<sup>3</sup>; Temperature 23°C +/- 3°C;  
In the intake and outlet area should not be any solid obstruction within 0,5 m.

a.) Operation condition:

13.000 1/min at free air flow
-------------------------------

Max. free-air flow ( $\Delta p = 0 / \dot{V} = \text{max.}$ )	24,0 m <sup>3</sup> /h	
Max. static pressure ( $\Delta p = \text{max.} / \dot{V} = 0$ )	215 Pa	

### 3.6 Sound Data

Measurement conditions: Sound pressure level: 1 Meter distance between microphone and the air intake.  
Sound power level: Acc. to DIN 45635 part 38 (ISO 10302)  
Measured in a semianchoic chamber with a background noise level of Lp(A) < 5 dB(A)  
For further measurement conditions see section 3.5

a.) Operation condition:

13.000 1/min at free air flow
-------------------------------

Optimal operating point	19,0 m <sup>3</sup> /h @ 36 Pa	
Sound power level at the optimal operating point	6,1 bel(A)	
Sound pressure level at free air flow, measured in rubber bands	44,0 dB(A)	

## 4 Environment

### 4.1 General

Min. permitted ambient temperature TU min.	-20 °C	
Max. permitted ambient temperature TU max.	60 °C	
Min. permitted storage temperature TL min.	-40 °C	
Max. permitted storage temperature TL max.	80 °C	

### 4.2 Climatic requirements\*)

IP-protection type (certified)	IP 54 **)	
Humidity requirements	humid temperature, cyclic; according to DIN EN 60068-2-38, 10 cycle and condensation water check; according to DIN EN ISO 6270-2, 14 days	
Radiation exposure	Solar radiation; according to DIN EN 60068-2-5	
Salt fog requirements	None	
Harmful gas requirements	None	

\*) Permitted application area:

The product is for the use in partial sheltered rooms or open, roofed areas. Direct exposure to water is allowed provided that this does not prevent the normal operation. Saline ambient conditions must be avoided.

Pollution degree 3 (according DIN EN 60664-1)

It occurs conductive pollution or dry non-conductive pollution which becomes conductive due to condensation.

\*\*\*) The specification of the IP protection refers to the conditions mentioned in certification of the fan. The above mentioned short description of the protection scope is not final. For detailed information of the respective protection scope and definitions, see certification as well as DIN EN 60529 (protection by housings) and ISO 20653 (for vehicles) with the letter K.

**Short description of the IP-protection type:**

Solid particle Protection: Dust tight.

Protection against deliberate contact: Protected against contact to hazardous parts with a wire.

Protection against water: Protected against the effects of continuous immersion in water.

Please require severity levels and specification parameters from the responsible development departments



## 5 Safety

### 5.1 Electrical Safety

Dielectric strength DIN EN 60950 (VDE 0805) and DIN EN 60335 (VDE 0700) A.) Type test Measuring conditions: After 48h of storage at 95% R.H. and 25°C. No arcing or breakdown is allowed! All connections together to ground. B.) Routine test Measuring conditions: At indoor climate. No arcing or breakdown is allowed! All connections together to ground.	500 VAC / 1 Min.  500 VAC / 1 Sec.	
Isolation resistance Measuring conditions: After 48h of storage at 95% R.H. and 25°C measured with U=500 VDC for 1 min.	RI > 10 MOhm	
Air and leakage distances	1,0 mm / 1,2 mm	
Protection class	III	

### 5.2 Approval Tests

CE	Yes
UL	Yes
VDE	Yes / Approval acc. to EN 60950 (VDE 0805) - Information technology equipment
CSA	Yes / C22.2 No. 113 Fans and Ventilators
CCC	No

The approval tests are observed to:

Maximal permitted operating voltage (see section 3.1) and max. permitted ambient temperature TU max.

## 6 Reliability

### 6.1 General

Life expectancy L10 at TU = 40 °C	57.500 h	
Life expectancy L10 at TU max.	35.000 h	
Life expectancy L10 Delta (40 °C)	110.000 h	

Copyright of this document and its content shall remain the property of the copyright holder. All rights are reserved. In the event of the grant of a patent or the registration of a utility model or trademark, all rights are reserved.

Schutzvermerk nach DIN 34, beachten

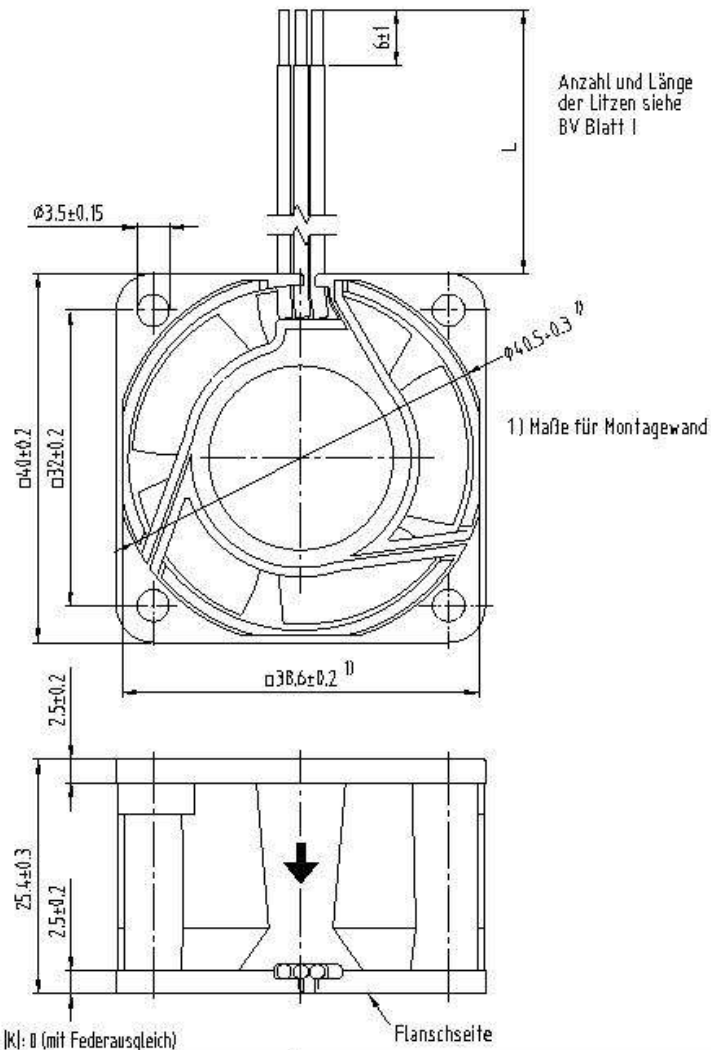

Axialspiel bei  
- Kugellagerung (K): 0 (mit Federausgleich)

Flanschseite

Tolerierung: DIN 7167  
Allgemeintoleranzen:

DIN 2768 - mK

				Datum	Name	Artikel	Maßstab
				Erstellt			
				Geprüft			
Index	Änd.-Nr.	Datum	Geändert von	<b>PAPST</b> PAPST-MOTOREN GmbH & Co KG D-78112 St. Georgen Germany		Zchg.-Nr.	Blatt
Zur Verwendung in Verteiler freigegeben von			an			Ers.f.Zchg.	