

SPECIFICATION CONTROL DRAWING

10603

TITLE	SPECIAL PURPOSE HOOKUP WIRE, DOUBLE INSULATION, 600 VOLT	Date	1-27-14	Revision	AB
This specification sheet forms a part of the latest issue of Raychem Specification 35, to the extent specified herein.					

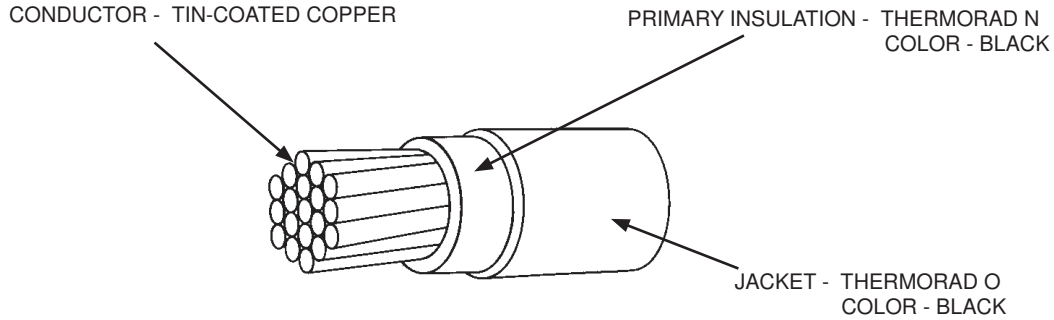

TABLE I. CONSTRUCTION DETAILS

PART NUMBER 1/	WIRE SIZE (AWG) or (MCM)	CONDUCTOR STRANDING (number x AWG)	MAXIMUM DIAMETER OF STRANDED CONDUCTOR (inch)	FINISHED WIRE		
				MAXIMUM RESISTANCE AT 20°C (ohms/1000 ft.)	DIAMETER (inch)	MAXIMUM WEIGHT (lbs/1000 ft.)
10603-14-0	14	37 x 30	.075	3.11	.175 ± .005	26.9
10603-12-0	12	37 x 28	.089	2.02	.189 ± .006	32.6
10603-10-0	10	37 x 26	.113	1.26	.213 ± .006	46.6
10603-8-0	8	133 x 29	.173	.701	.280 ± .008	79.6
10603-6-0	6	133 x 27	.217	.445	.324 ± .010	115.
10603-4-0	4	133 x 25	.274	.280	.380 ± .011	170.
10603-2-0	2	665 x 30	.340	.183	.466 ± .014	269.
10603-0-0	0	1045 x 30	.425	.116	.560 ± .017	404.
10603-00-0	00	1330 x 30	.475	.091	.616 ± .018	503.
10603-000-0	000	1665 x 30	.540	.071	.669 ± .020	609.
10603-0000-0	0000	2109 x 30	.605	.056	.803 ± .024	815.
10603-250-0	250	2499 x 30	.716	.045	.932 ± .028	1044.
10603-350-0	350	3458 x 30	.840	.032	1.066 ± .032	1415.

Users should evaluate the suitability of this product for their application. Specifications are subject to change without notice. Tyco Electronics Corporation also reserves the right to make changes in materials or processing, which do not affect compliance with any specification, without notification to Buyer.

1/ COLORS SHALL BE IN ACCORDANCE WITH MIL-STD-681. OTHER CODES AND SUFFIXES MAY BE ADDED TO THE PART NUMBER, AS NECESSARY, TO CAPTURE ANY ADDITIONAL REQUIREMENTS IMPOSED BY THE PURCHASE ORDER.

Thermorad, Raychem, TE Connectivity, TE connectivity (logo), and TE (logo) are trademarks.

DIMENSIONS ARE IN INCHES AND, UNLESS OTHERWISE DESIGNATED, ARE NOMINAL.

THIS SPECIFICATION SHEET TAKES PRECEDENCE OVER DOCUMENTS REFERENCED HEREIN. REFERENCED DOCUMENTS SHALL BE OF THE ISSUE IN EFFECT ON DATE OF INVITATION FOR BID.



Raychem Wire & Cable
501 Oakside Avenue
Redwood City, CA 94063-3800
Phone: 1-800-227-8816
Fax: 1-650-361-6297



TABLE II. PERFORMANCE DETAILS

PART NUMBER <u>1/</u>	BEND TESTING			
	MANDREL DIAMETER (inches) (± 3%)		WEIGHT (lbs) (± 3%)	
	IMMERSION, LIFE CYCLE, AND ACCELERATED AGING	COLD BEND	IMMERSION, LIFE CYCLE, AND ACCELERATED AGING	COLD BEND
10603-14-0	3.00	3.00	2.00	5.00
10603-12-0	3.00	3.00	2.00	6.00
10603-10-0	3.00	3.00	2.00	6.00
10603-8-0	3.00	3.00	2.00	10.0
10603-6-0	4.00	4.00	2.00	10.0
10603-4-0	6.00	6.00	3.00	15.0
10603-2-0	8.00	8.00	3.00	15.0
10603-0-0	10.0	10.0	4.00	20.0
10603-00-0	12.0	12.0	6.00	30.0
10603-000-0	13.5	13.5	6.00	30.0
10603-0000-0	15.0	15.0	6.00	30.0
10603-250-0	18.5	18.5	6.00	30.0
10603-350-0	21.0	21.0	6.00	30.0

WIRE RATINGS AND ADDITIONAL REQUIREMENTS

TEMPERATURE RATING: 125°C

Maximum continuous conductor temperature

VOLTAGE RATING: 600 volts (rms) at sea level

ACCELERATED AGING: 175 ± 4°C for 4 hours

CONCENTRICITY: 70% (minimum)

FLAMMABILITY: Self extinguishing within 60 seconds (maximum), 25% (maximum) of flag burned; no flaming of cotton

INSULATION ELONGATION AND TENSILE STRENGTH:

Each Layer,

Elongation, 100% (minimum)

Tensile Strength, 1500 lbf/in² (minimum)

INSULATION FLAWS:

Spark Test, 5.7 kV (rms) at 3 kHz

Impulse Dielectric Test, 8.0 kV (peak)

INSULATION RESISTANCE:

100 megohms for 1000 ft. (minimum)

JACKET THICKNESS: .0300 in. (nominal), AWG 14-10

.0375 in. (nominal), AWG 8-4

.0400 in. (nominal), AWG 2-000

.0600 in. (nominal), AWG 0000-350 MCM

LIFE CYCLE: 150 ± 3°C for 96 hours

LOW TEMPERATURE-COLD BEND: -55 ± 2°C for 4 hours

OIL RESISTANCE:

Brayco 883 (or Royco 770) per MIL-PRF-46170, 20% (maximum) swell after 20 hours at 90°C;

SAE Grade 15W-40 Lubricating Oil per MIL-PRF-2104, 20% (maximum) swell after 20 hours at 90°C;

SAE Grade 30 Lubricating Oil, 20% (maximum) swell after 20 hours at 90°C

SHRINKAGE: 150 ± 3°C for 4 hours, 0.5 in. (maximum) sum of both ends

VOLTAGE WITHSTAND (Post Environmental): 3000 volts (rms)

Replaces 34/7010

1/ See footer section on page 1