

MSP430-CCRF development board User's manual



All boards produced by Olimex are ROHS compliant
Revision C, July 2013
OLIMEX Ltd, All rights reserved

INTRODUCTION:

MSP430-CCRF is development board with CC430F5137IRGZ microcontroller by Texas Instruments. This ultra-low-power microcontroller has integrated CC1101 RF transceiver. The board has also UEXT, which can be modified as device or host. MSP430-CCRF can communicate with other boards with integrated CC1101 RF transceiver via radio connection.

BOARD FEATURES:

- Microcontroller: **CC430F5137IRGZ**
- JTAG
- UEXT
- PWR jack for 2 x 1.5V AA batteries
- On-board voltage regulator
- On-board pcb antenna
- Supported radio frequencies bands 868/915 MHz – software selectable. By default – 868 MHz.
- Maximal permissible distance between two MSP430-CCRF boards depends on RF chip's output power, data transfer rate and the selected radio frequency band. For more information, see the table below.
- User button
- Status LED
- RTC crystal
- Extension pin holes for most of the microcontroller pins
- FR-4, 1.00 mm, soldermask, component print
- Dimensions: 78.49 x 39.12mm (3.09 x 1.54")

<i>RF Frequency</i>	<i>Output Power</i>	<i>Data Rate</i>	<i>Measured Distance</i>
868MHz	10dBm	1.2kBaud	155m
868MHz	10dBm	38.4kBaud	110m
868MHz	10dBm	250kBaud	85m
915MHz	10dBm	1.2kBaud	140m
915MHz	10dBm	38.4kBaud	100m
915MHz	10dBm	250kBaud	60m

This measurements were taken via using “RF Connection_toggle LED” demo software loaded at two alike MSP430-CCRF boards!

ELECTROSTATIC WARNING:

The **MSP430-CCRF** board is shipped in protective anti-static packaging. The board must not be subject to high electrostatic potentials. General practice for working with static sensitive devices should be applied when working with this board.

BOARD USE REQUIREMENTS:

Cables: The cable you will need depends on the programmer/debugger you would use. If you use MSP-JTAG-TINY-V2 or MSP-JTAG-ISO-MK2, you will need USB A-B cable. If you use MSP-JTAG, you will need LPT cable.

Hardware: Programmer/debugger MSP-JTAG-TINY-V2, MSP-JTAG-ISO-MK2 or other compatible programming/debugging tool.

PROCESSOR FEATURES:

MSP430-CCRF board use microcontroller **CC430F5137IRGZFBD100** with these features:

- True System-on-Chip (SoC) for Low-Power Wireless Communication Applications
- Wide Supply Voltage Range: 1.8 V to 3.6 V
- Ultra-Low Power Consumption:
 - CPU Active Mode (AM): 160 μ A/MHz
 - Standby Mode (LPM3 RTC Mode): 2.0 μ A
 - Off Mode (LPM4 RAM Retention): 1.0 μ A
 - Radio in RX: 15 mA, 250 kbps, 915 MHz
- MSP430™ System and Peripherals
 - 16-Bit RISC Architecture, Extended Memory, up to 20-MHz System Clock
 - Wake-Up From Standby Mode in Less Than 6 μ s
 - Flexible Power Management System with SVS and Brownout
 - Unified Clock System with FLL
 - 16-Bit Timer TA0, Timer_A with Five Capture/Compare Registers
 - 16-Bit Timer TA1, Timer_A with Three Capture/Compare Registers
 - Hardware Real-Time Clock
 - Two Universal Serial Communication Interfaces
 - USCI_A0 supporting UART, IrDA, SPI
 - USCI_B0 supporting I²C, SPI

- 12-Bit A/D Converter With Internal Reference, Sample-and-Hold, and Autoscan Features
- Comparator
- 128-bit AES Security Encryption/Decryption Coprocessor
- 32-Bit Hardware Multiplier
- Three-Channel Internal DMA
- Serial On-board Programming, No External Programming Voltage Needed
- Embedded Emulation Module (EEM)
- High-Performance Sub-1-GHz RF Transceiver Core
 - Wide Supply Voltage Range: 2.0 V to 3.6 V
 - Frequency Bands: 300 MHz to 348 MHz, 389 MHz to 464 MHz, and 779 MHz to 928 MHz.
 - Programmable Data Rate From 0.6 kBaud to 500 kBaud
 - High Sensitivity (-117 dBm at 0.6 kBaud, -111 dBm at 1.2 kBaud, 315 MHz, 1% Packet Error Rate)
 - Excellent Receiver Selectivity and Blocking Performance
 - Programmable Output Power Up to +12 dBm for All Supported Frequencies
 - 2-FSK, 2-GFSK, and MSK Supported as well as OOK and Flexible ASK Shaping
 - Flexible Support for Packet-Oriented Systems: On-Chip Support for Sync Word Detection, Address Check, Flexible Packet Length, and Automatic CRC Handling
 - Support for Automatic Clear Channel Assessment (CCA) Before Transmitting (for Listen-Before-Talk Systems)
 - Digital RSSI Output
 - Suited for Systems Targeting Compliance With EN 300 220 (Europe) and FCC CFR Part 15 (US)
 - Suited for Systems Targeting Compliance With Wireless M-Bus Standard EN 13757-4:2005
 - Support for Asynchronous and Synchronous Serial Receive/Transmit Mode for Backward Compatibility With Existing Radio Communication Protocols

Program (KB)	SRAM (KB)	USCI			ADC12_A	Comp_B	I/O
		Timer_A (1)	Channel A: UART/LIN /IrDA/SPI	Channel B: SPI/ I ² C			
32	4	5, 3	1	1	6 ext/ 4 int ch.	6 ch.	30

(1) 5, 3 - represents two instantiations of Timer_A, the first instantiation having 5 and the second instantiation having 3 capture compare registers and PWM output generators, respectively.

BLOCK DIAGRAM:

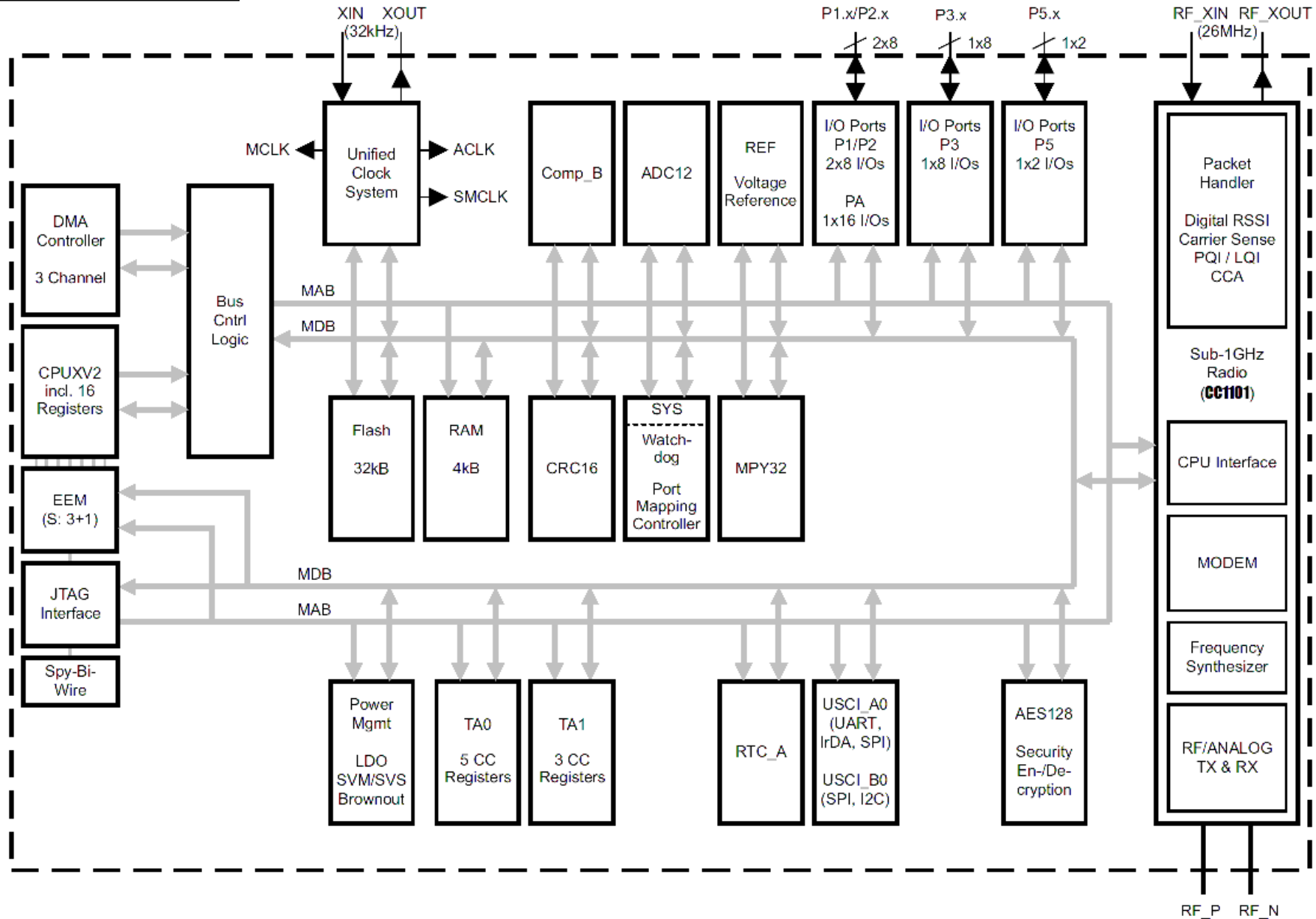

MEMORY ORGANIZATION:

		CC430F5137⁽¹⁾
Main Memory (flash)	Total Size	32kB
Main: Interrupt vector		00FFFFh to 00FF80h
Main: code memory	Bank 0	32kB 00FFFFh to 008000h
RAM	Total Size	4kB
	Sect 1	2kB 002BFFh to 002400h
	Sect 0	2kB 0023FFh to 001C00h
Device Descriptor		128 B 001AFFh to 001A80h
		128 B 001A7Fh to 001A00h
Information memory (flash)	Info A	128 B 0019FFh to 001980h
	Info B	128 B 00197Fh to 001900h
	Info C	128 B 0018FFh to 001880h
	Info D	128 B 00187Fh to 001800h
Bootstrap loader (BSL) memory (flash)	BSL 3	512 B 0017FFh to 001600h
	BSL 2	512 B 0015FFh to 001400h
	BSL 1	512 B 0013FFh to 001200h
	BSL 0	512 B 0011FFh to 001000h
Peripherals		4 KB 000FFFh to 0h

(1) All memory regions not specified here are vacant memory, and any access to them causes a Vacant Memory Interrupt

SCHEMATIC:

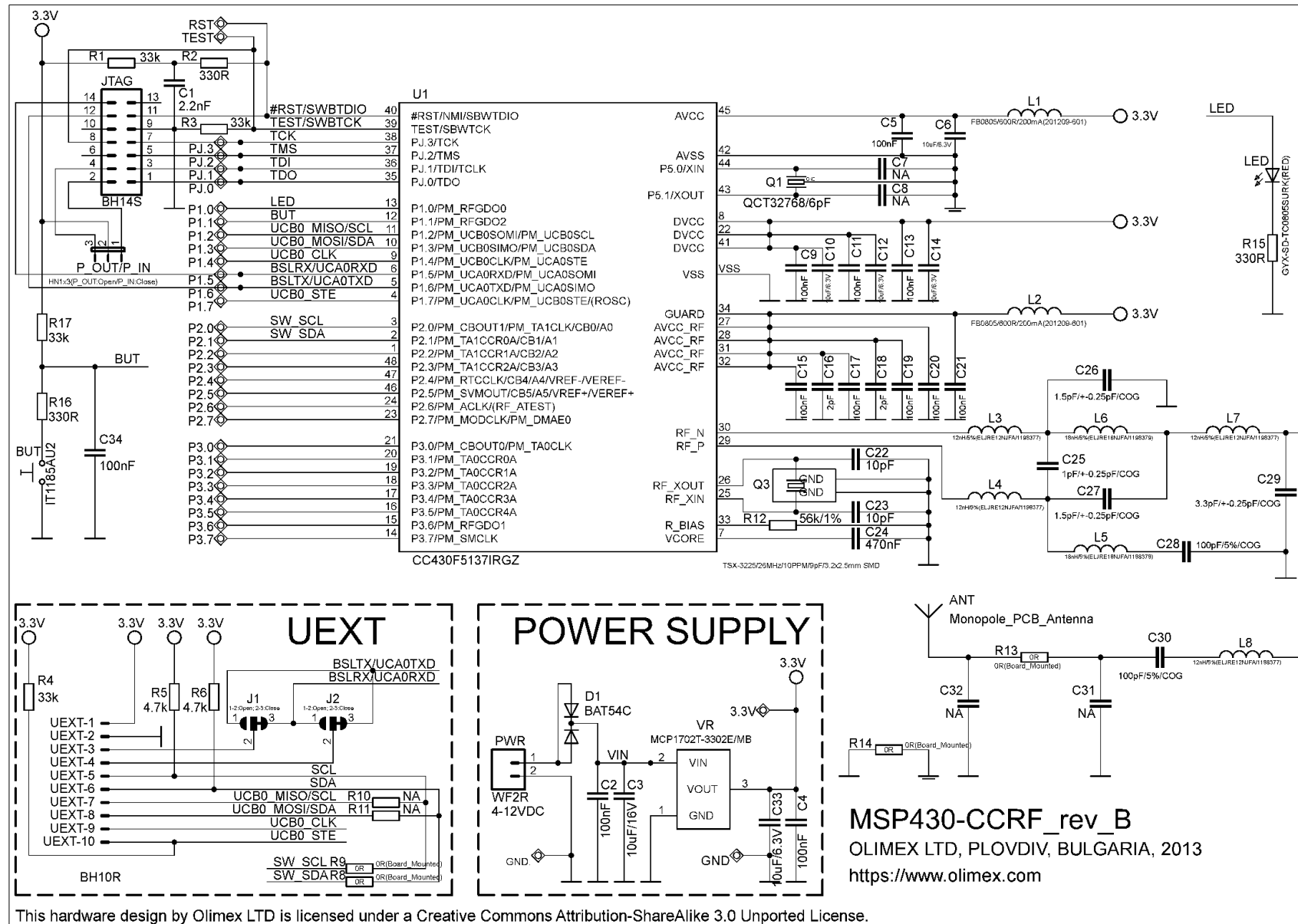

This hardware design by Olimex LTD is licensed under a Creative Commons Attribution-ShareAlike 3.0 Unported License.

MSP430-CCRF_rev_B
 OLIMEX LTD, PLOVDIV, BULGARIA, 2013
<https://www.olimex.com>

BOARD LAYOUT:

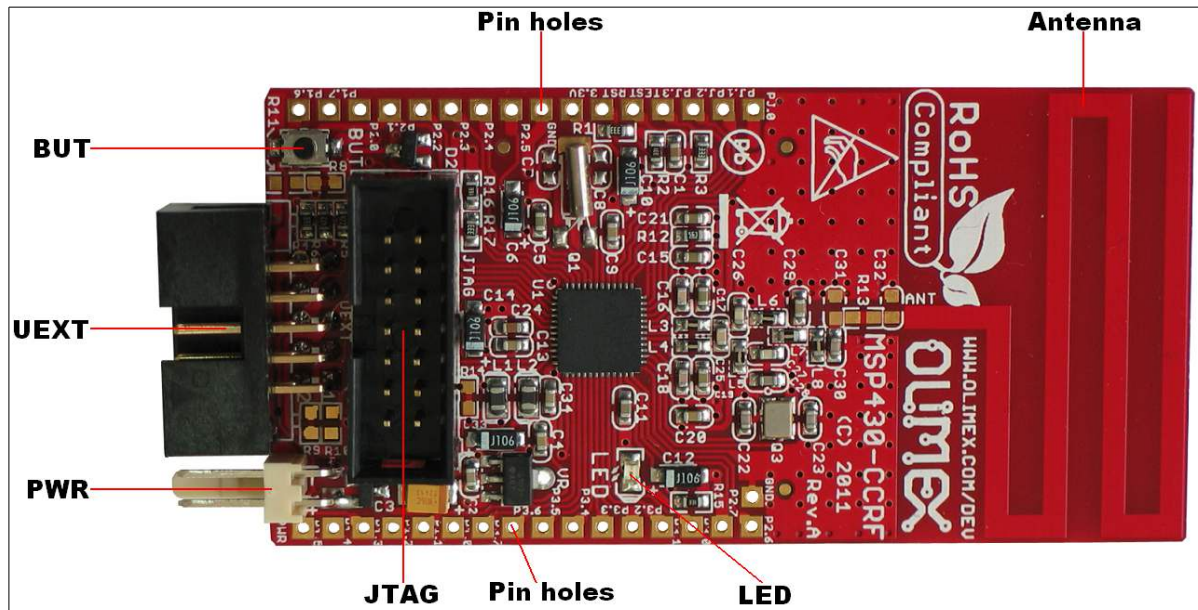

POWER SUPPLY CIRCUIT:

MSP430-CCRF can take power from:

- External power supply via PWR connector 4 - 12 VDC
- JTAG

The programmed board power consumption is about 25 mA with all peripherals enabled.

RESET CIRCUIT:

MSP430-CCRF reset circuit includes R2 (330Ω), R1 (33k), C1 (2.2nF), JTAG pin 11 and CC430F5137IRGZ pin 40 (#RST/SWBTDIO).

CLOCK CIRCUIT:

Quartz crystal Q1 32.768 kHz is connected to CC430F5137IRGZ pin 44 (P5.0/XIN) and pin 43 (P5.1/XOUT).

Quartz crystal Q3 26 MHz is connected to CC430F5137IRGZ pin 25 (RF_XIN) and pin 26 (RF_XOUT).

JUMPER DESCRIPTION:

J1



This jumper, when is in position 1-2 – UEXT pin 3 (signal TX) is connected to CC430F5137IRGZ pin 5 (signal BSLTX/UCA0TXD); when the jumper is in position 2-3- UEXT pin 3 (signal TX) is connected to CC430F5137IRGZ pin 6 (signal BSLRX/UCA0RXD)

Default state is shorted in position 2-3.

J2



This jumper, when is in position 1-2 – UEXT pin 4 (signal RX) is connected to CC430F5137IRGZ pin 6 (signal BSLRX/UCA0RXD); when the jumper is in position 2-3 - UEXT pin 4 (signal RX) is connected to CC430F5137IRGZ pin 5 (signal BSLTX/UCA0TXD)

Default state is shorted in position 2-3.

When jumpers J1 and J2 are shorted in position 1-2 – the board is configured as host and can be used as host for some of our module boards. When these jumpers are shorted in position 2-3 – the board is configured as device and can be used as module board.

P_OUT/P_IN



This jumper P_OUT/P_IN jumper declares if the board has to be powered externally via the JTAG debugger or it is internally powered.

Default state is shorted in position 2-3.

It is safer to switch the P_OUT position when you do not want to provide power via the JTAG debugger.

INPUT/OUTPUT:

Status Led with name **LED (red)** connected to CC430F5137IRGZ pin 13 (P1.0/PM_RFGDO0).

User button with name **BUT** connected to CC430F5137IRGZ pin 12 (P1.1/PM_RFGDO2).

EXTERNAL CONNECTORS DESCRIPTION:

JTAG:

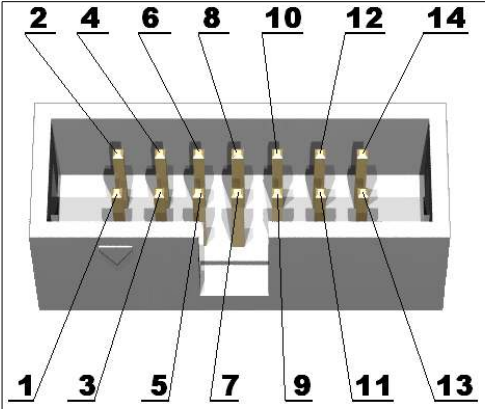

Pin #	Signal Name	Pin #	Signal Name
1	TDO	2	JTAG power supply
3	TDI	4	VCC
5	TMS	6	Not Connected
7	TCK	8	TEST/SWBTCK
9	GND	10	Not Connected
11	#RST/SWBDIO	12	BSLTX/UCA0TXD
13	Not Connected	14	BSLRX/UCA0RXD

PWR:

Pin #	Signal Name
1	VIN
2	GND



UEXT:

Pin #	Signal Name
1	VCC
2	GND
3	TX
4	RX
5	SCL
6	SDA
7	UCB0_MISO/SCL
8	UCB0_MOSI/SDA
9	UCB0_CLK
10	UCB0_STE

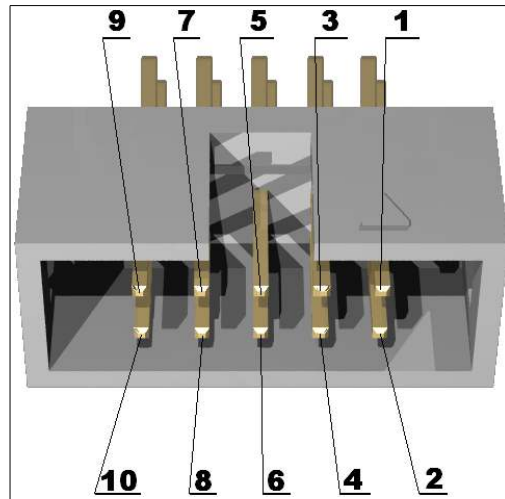

Pin holes:

Pin #	Signal Name	Pin #	Signal Name
PJ.0	TDO	P2.6	P2.6
PJ.1	TDI	P2.7	P2.7
PJ.2	TMS	P3.0	P3.0
PJ.3	TCK	P3.1	P3.1
TEST	TEST/SWBTCK	P3.2	P3.2
RST	#RST/SWBDIO	P3.3	P3.3
3.3V	VCC	P3.4	P3.4
GND	GND	P3.5	P3.5
P2.5	P2.5	P3.6	P3.6
P2.4	P2.4	P3.7	P3.7
P2.3	P2.3	P1.0	LED
P2.2	P2.2	P1.1	BUT
P2.1	SW_SDA	P1.2	UCB0_MISO/SCL
P2.0	SW_SCL	P1.3	UCB0_MOSI/SDA
P1.7	UCB0_STE	P1.4	UCB0_CLK
P1.6	BSLTX/UCA0TXD	P1.5	BSLRX/UCA0RXD

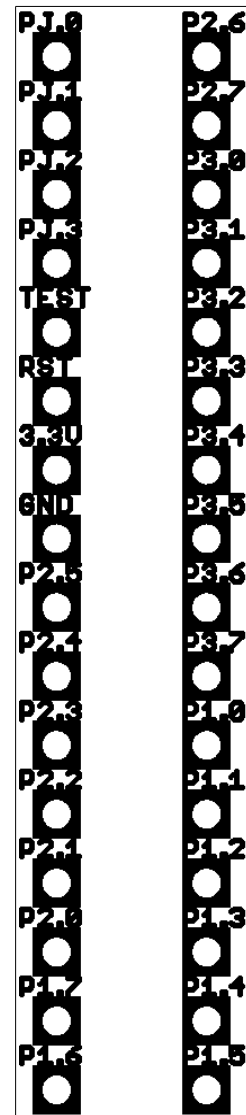

MECHANICAL DIMENSIONS:

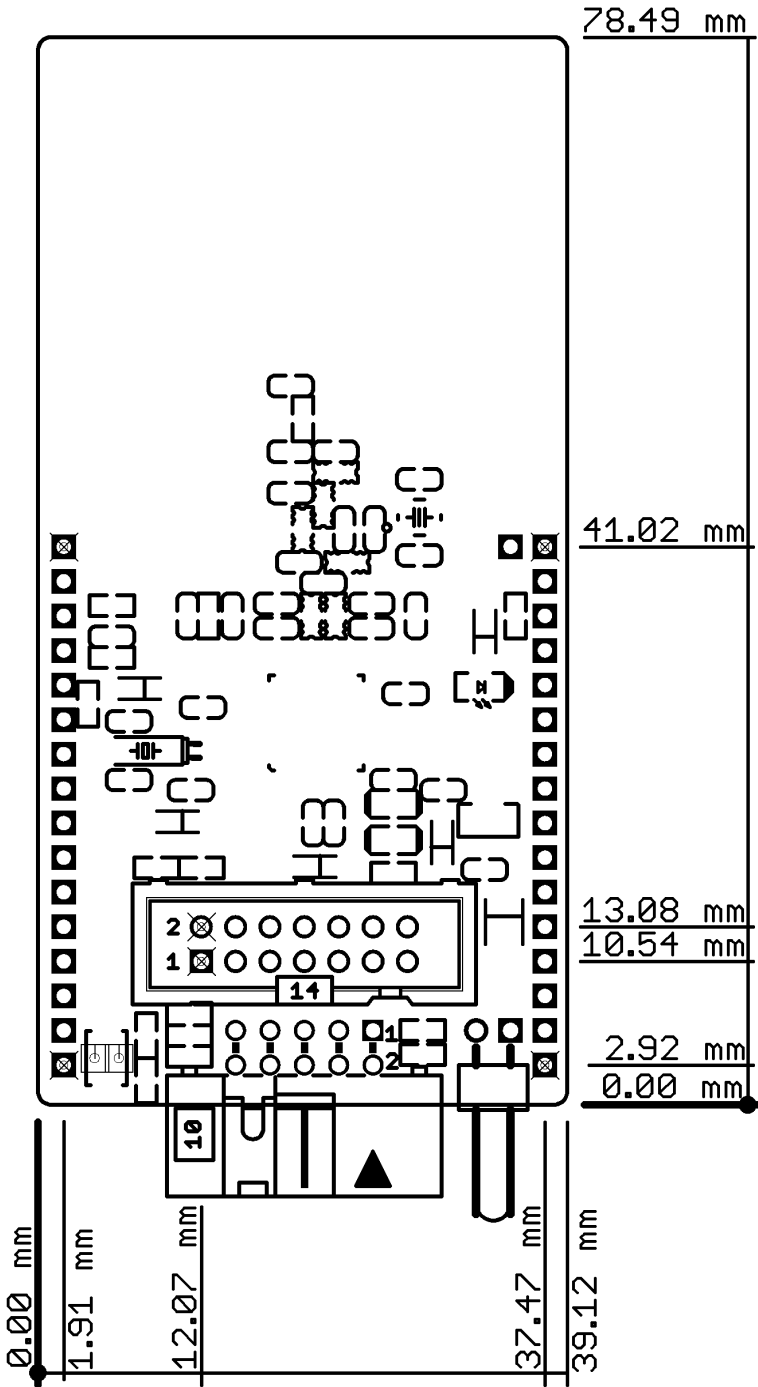

AVAILABLE DEMO SOFTWARE:

There is a number of example for MSP430-CCRF compatible with IAR Embedded Workbench for MSP430 v4.21. Unfortunately, it is possible that the code would not compile under IAR for MSP430 v5.xx due to incompatibility between versions. The code is available at the MSP430-CCRF web page at OLIMEX LTD web site.

- Blinking Led sourced by DCO
- Blinking Led sourced by RTC
- Blinking Led sourced by RTC and USART Echo
- Toggle LED when BUT is pressed
- RF Connection_ press BUT
- RF Connection_toggle LED

ORDER CODE:

MSP430-CCRF - assembled and tested board

How to order?

You can order to us directly or by any of our distributors.
Check our web <https://www.olimex.com> for more info.

Revision history:

- Board's revision: Rev. A, May 2011
- Rev. B, Mart 2013
1. Added P_OUT/P_IN jumper to solve power short-circuits when the board is powered from the JTAG
 2. The RTC capacitors C7 and C8 have been removed and the internal CCRF capacitors have been used instead.
 3. The drill size under U1 is changed from 1.5mm to 0.6mm
 4. Removed arrows from the bottom silk
 5. Power supply white print changed from 3-12VDC to 4-12VDC
- Manual's revision: Rev. A, June 2011
- in BOARD FEATURES - added Supported radio frequencies bands, Maximal permissible distance between two MSP430-CCRF boards, RTC crystal and "Not typical power jack" changed to "PWR jack for 2 x 1.5V AA batteries"
- Rev. B, November 2011
- **BOARD FEATURES** – added is table which describes maximal permissible distance between two MSP430-CCRF boards versus different RF settings.
 - **SCHEMATIC** – is updated to last version – with changed C22 and C23 values from 15pF to 10pF.
 - **AVAILABLE DEMO SOFTWARE** – "RF Connection_ press BUT to send a packet and toggle LED when packet is

received" is changed to "RF Connection_press BUT".
"RF Connection_toggle LED" was added.

Rev. C, November 2013

- **SCHEMATIC** – revision B of the schematic added
- updated supported debuggers list
- improved the spelling of the document
- added more info about revisions
- expanded warranty and support page

For product support, hardware information and error reports mail to: support@olimex.com. Note that we are primarily a hardware company and our software support is limited.

Please consider reading the paragraph below about the warranty of Olimex products.

All goods are checked before they are sent out. In the unlikely event that goods are faulty, they must be returned, to OLIMEX at the address listed on your order invoice.

OLIMEX will not accept goods that have clearly been used more than the amount needed to evaluate their functionality.

If the goods are found to be in working condition, and the lack of functionality is a result of lack of knowledge on the customers part, no refund will be made, but the goods will be returned to the user at their expense.

All returns must be authorized by an RMA Number. Email support@olimex.com for authorization number before shipping back any merchandise. Please include your name, phone number and order number in your email request.

Returns for any unaffected development board, programmer, tools, and cables permitted within 7 days from the date of receipt of merchandise. After such time, all sales are considered final. Returns of incorrect ordered items are allowed subject to a 10% restocking fee. What is unaffected? If you hooked it to power, you affected it. To be clear, this includes items that have been soldered to, or have had their firmware changed. Because of the nature of the products we deal with (prototyping electronic tools) we cannot allow returns of items that have been programmed, powered up, or otherwise changed post shipment from our warehouse.

All returned merchandise must be in its original mint and clean condition. Returns on damaged, scratched, programmed, burnt, or otherwise 'played with' merchandise will not be accepted.

All returns must include all the factory accessories which come with the item. This includes any In-Circuit-Serial-Programming cables, anti-static packing, boxes, etc.

With your return, enclose your PO#. Also include a brief letter of explanation of why the merchandise is being returned and state your request for either a refund or an exchange. Include the authorization number on this letter, and on the outside of the shipping box.

Please note: It is your responsibility to ensure that returned goods reach us. Please use a reliable form of shipping. If we do not receive your package we will not be held liable.

Shipping and handling charges are not refundable. We are not responsible for any shipping charges of merchandise being returned to us or returning working items to you.

The full text might be found at <https://www.olimex.com/wiki/GTC#Warranty> for future reference.