

Prepared		<b>Product Specifications</b>  <b>AN15851A</b>	Ref No.	A
Checked			Total Page	21
Approved			Page No.	1

Structure	Silicon Monolithic Bipolar IC
Appearance	36-USO Pin Plastic Package (USONF-36D)
Application	IC for Color TV
Function	4-Input AV Switch IC with RGB-YUV Converter

A	Absolute Maximum Ratings				
No.	Item	Symbol	Ratings	Unit	Note
1	Storage Temperature	Tstg	-55 ~ +150	°C	1
2	Operating Ambient Temperature	Topr	-20 ~ +70	°C	1
3	Operating Ambient Pressure	Popr	$1.013 \times 10^5 \pm 0.61 \times 10^5$	Pa	
4	Operating Constant Acceleration	Gopr	9810	m / s <sup>2</sup>	
5	Operating Shock	Sopr	4900	m / s <sup>2</sup>	
6	Power Supply Voltage	Vcc	14	V	
7	Power Supply Current	Icc	60	mA	
8	Power Dissipation	PD	840	mW	

Operating Supply Voltage Range	Vcc	8.1V ~ 9.9V
--------------------------------	-----	-------------

Note 1) The temperature of all items shall be Ta = 25°C except storage temperature and operating ambient temperature.

Eff. Date	Eff. Date	Eff. Date	Eff. Date	
18 JAN 2002	6 MAR 2002	10 APR 2002		

Prepared		<b>Product Specifications</b> <b>AN15851A</b>	Ref No.	B-1
Checked			Total Page	21
Approved			Page No.	2

B Electrical Characteristics (V <sub>CC</sub> =9V, unless otherwise specified, the ambient temperature is 25°C±2°C)												
No.	Item	Symbol	Test Cct.	Condition	Limit			Unit	Note			
					Min	Typ	Max					
1	Quiescent Current	I <sub>CQ</sub>	1	No input	38	46	52	mA				
	[VIDEO BLOCK]											
2	Video Gain (OUT1)	G <sub>V1/6</sub>	1	Select : 6dB f =15kHz, Vin=0.5Vp-p		5.0	5.7	6.4	dB			
		G <sub>V1CV/6</sub>			RGB → YUV	4.5	5.7	6.9				
		G <sub>V1/4</sub>	1		Select : 4.4dB f =15kHz, Vin=0.5Vp-p		3.4	4.1			4.8	
		G <sub>V1CV/4</sub>				RGB → YUV	2.9	4.1			5.3	
	Video Gain (OUT2)	G <sub>V2/6</sub>	1	Select : 6dB f =15kHz, Vin=0.5Vp-p			5.0	5.7	6.4	dB		
		G <sub>V2CV/6</sub>				RGB → YUV	4.5	5.7	6.9			
		G <sub>V2MX/6</sub>			YCmix NON RGB → YUV	4.5	5.7	6.9	1			
		G <sub>V2/0</sub>	1		Select : 0dB f =15kHz, Vin=0.5Vp-p		-1.0	-0.3	0.4	dB		
		G <sub>V2CV/0</sub>				RGB → YUV	-1.5	-0.3	0.9			
		G <sub>V2MX/0</sub>				YCmix NON RGB → YUV	-1.5	-0.3	0.9			2
	3	Video Frequency Characteristics	f <sub>Y</sub>	1		f=100kHz, Vin=0.5Vp-p as reference 0dB, measure the frequency at output -3dB point.		20	30	-	MHz	
			f <sub>UV</sub>				10	20	-			
f <sub>CONV</sub>			10				20	-				
f <sub>MIX</sub>			10		20		-					
4	Input Dynamic Range	V <sub>DYUV</sub>	1	f = 20kHz, maximum input when output at THD < 2.0%.		2.0	2.4	-	Vp-p			
		V <sub>DYCONV</sub>			2.0	2.4	-					
		V <sub>DYMIX</sub>			1.9	2.3	-					
5	Video Crosstalk	C <sub>M</sub>	1	f=5MHz, Vin=1Vp-p		50	60	-	dB			
	Y and U Crosstalk	C <sub>YU</sub>			35	40	-					
	Y and V Crosstalk	C <sub>YV</sub>			35	40	-					
	U and V Crosstalk	C <sub>UV</sub>			35	40	-					
6	Mute Ratio(V/SY OUT1)	MR	1	Vin=0.5Vp-p, f=15kHz		40	50	-	dB			

Note 1 : SELECT GAIN (U/SC & V/SY = 6dB ; Y/SY/CV = 0dB; Both input U/SC & V/SY)

Note 2 : SELECT GAIN (U/SC & V/SY = 0dB ; Y/SY/CV = 0dB; Both input U/SC & V/SY)

Eff. Date	Eff. Date	Eff. Date	Eff. Date	
18 JAN 2002	6 MAR 2002	10 APR 2002		

Prepared		<b>Product Specifications</b>  <b>AN15851A</b>	Ref No.	B-1
Checked			Total Page	21
Approved			Page No.	3

B Electrical Characteristics		(V <sub>CC</sub> =9V, unless otherwise specified, the ambient temperature is 25°C ± 2°C)							
No	Item	Symbol	Test Circuit	Conditions	Limits			Unit	Note
					min	typ	max		
	[AUDIO BLOCK]								
7	Audio Gain	G <sub>A</sub>	1	f=1kHz, 1V <sub>p-p</sub>	-0.5	0	0.5	dB	
8	Audio Frequency Characteristics	f <sub>A</sub>	1	f=1kHz, V <sub>in</sub> =1V <sub>p-p</sub> as reference 0dB, measure the frequency at output -3dB point.	36	41	-	kHz	
9	Input Dynamic Range	V <sub>DYA</sub>	1	f=1kHz, maximum input when output at THD < 1.5%	2.8	2.9	-	V <sub>rms</sub>	
10	Source Crosstalk	C <sub>A</sub>	1	f=1kHz, V <sub>in</sub> =1V <sub>p-p</sub> Din Audio	80	85	-	dB	
	Channel Crosstalk	C <sub>LR</sub>			80	85	-		
	[IIC Interface]								
11	Suction current during ACK	I <sub>ACK</sub>	1	Max. suction current value of Pin 36 at 0.4V.	3.0	10	-	mA	
12	SCL, SDA signal input high level	V <sub>IHI</sub>	1		3.0	-	5.5	V	
13	SCL, SDA signal input low level	V <sub>ILO</sub>	1		0	-	1.5	V	
14	Max. frequency allowable to input	f <sub>imax</sub>	1		-	-	100	kbit/s	

Eff. Date	Eff. Date	Eff. Date	Eff. Date	
18 JAN 2002	6 MAR 2002	10 APR 2002		

Prepared		<b>Product Specifications</b> (Reference Data for Designing) <b>AN15851A</b>	Ref No.	B-2
Checked			Total Page	21
Approved			Page No.	4

B Electrical Characteristics		(VCC=9V, unless otherwise specified, the ambient temperature is 25°C ± 2°C)							
No	Item	Symbol	Test Circuit	Conditions	Limits			Unit	Note
					min	typ	max		
	[IIC Interface]								
1	Bus free before start	t <sub>BUF</sub>			4.0	-	-	μs	
2	Start condition set-up time	t <sub>SU, STA</sub>			4.0	-	-	μs	
3	Start condition hold time	t <sub>HD, STA</sub>			4.0	-	-	μs	
4	Low period SCL, SDA	t <sub>LO</sub>			4.0	-	-	μs	
5	High period SCL	t <sub>HI</sub>			4.0	-	-	μs	
6	Rise time SCL, SDA	t <sub>R</sub>			-	-	1.0	μs	
7	Fall time SCL, SDA	t <sub>F</sub>			-	-	0.35	μs	
8	Data set-up time (write)	t <sub>SU, DAT</sub>			0.25	-	-	μs	
9	Data hold time (write)	t <sub>HD, DAT</sub>			0	-	-	μs	
10	Acknowledge set-up time	t <sub>SU, ACK</sub>			-	-	3.5	μs	
11	Acknowledge hold time	t <sub>HD, ACK</sub>			0	-	-	μs	
12	Stop condition set-up time	t <sub>SU, STO</sub>			4.0	-	-	μs	

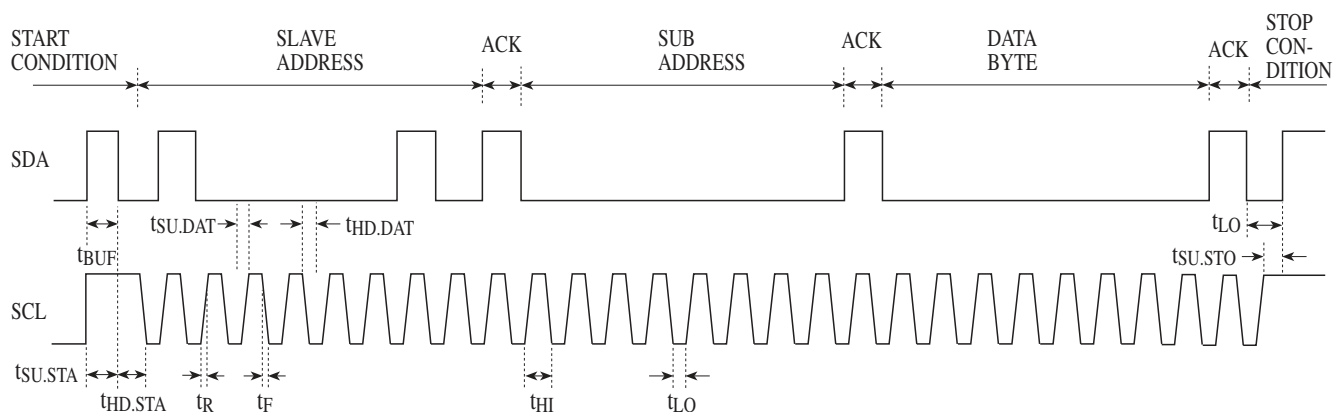

Note) The above characteristics are reference values on IC designing and not guaranteed by shipping inspection.

Eff. Date	Eff. Date	Eff. Date	Eff. Date
18 JAN 2002	6 MAR 2002	10 APR 2002	

Prepared		<b>Product Specifications</b> (Reference Data for Designing) <b>AN15851A</b>	Ref No.	B-2
Checked			Total Page	21
Approved			Page No.	5

B		Electrical Characteristics (V <sub>CC</sub> =9V, unless otherwise specified, the ambient temperature is 25°C ± 2°C)							
No	Item	Symbol	Test Circuit	Conditions	Limits			Unit	Note
					min	typ	max		
	[Video Block]								
13	Total Harmonic Distortion 1	THD <sub>V</sub>	1	V <sub>in</sub> =0.5V <sub>p-p</sub> , f=20kHz	-	0.4	1.0	%	
	[Audio Block]								
14	Total Harmonic Distortion 2	THD <sub>A</sub>	1	V <sub>in</sub> =1V <sub>rms</sub> , f=1kHz Din Audio	-	0.1	0.3	%	

Eff. Date	Eff. Date	Eff. Date	Eff. Date	
18 JAN 2002	6 MAR 2002	10 APR 2002		



Prepared		<b>Product Specifications</b> <b>AN15851A</b>	Ref No.	D
Checked			Total Page	21
Approved			Page No.	7

### Circuit Function Block Diagram

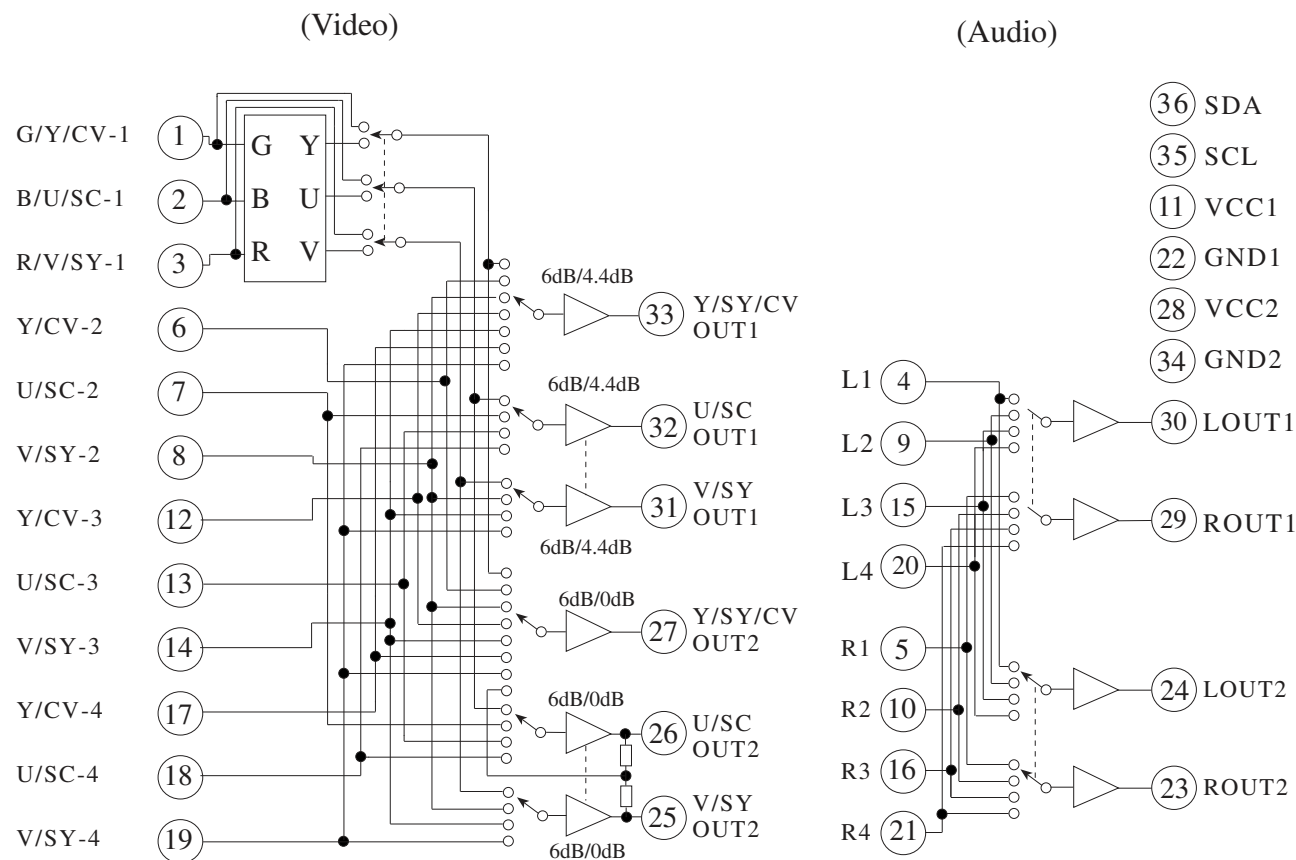

### Pin Descriptions

Pin No.	Pin Name	Pin No.	Pin Name	Pin No.	Pin Name
1	G/Y/CV-1 Input	13	U/SC-3 Input	25	V/SY OUT2
2	B/U/SC-1 Input	14	V/SY-3 Input	26	U/SC OUT2
3	R/V/SY-1 Input	15	L3 Input	27	Y/SY/CV OUT2
4	L1 Input	16	R3 Input	28	VCC2
5	R1 Input	17	Y/CV-4 Input	29	ROUT1
6	Y/CV-2 Input	18	U/SC-4 Input	30	LOUT1
7	U/SC-2 Input	19	V/SY-4 Input	31	V/SY OUT1
8	V/SY-2 Input	20	L4 Input	32	U/SC OUT1
9	L2 Input	21	R4 Input	33	Y/SY/CV OUT1
10	R2 Input	22	GND1	34	GND2
11	VCC1	23	ROUT2	35	SCL
12	Y/CV-3 Input	24	LOUT2	36	SDA

Eff. Date	Eff. Date	Eff. Date	Eff. Date
18 JAN 2002	6 MAR 2002	10 APR 2002	

Prepared		<b>Product Specifications</b> <b>AN15851A</b>	Ref No.	E
Checked			Total Page	21
Approved			Page No.	8

Package Name	USONF-36D
--------------	-----------

Unit : mm

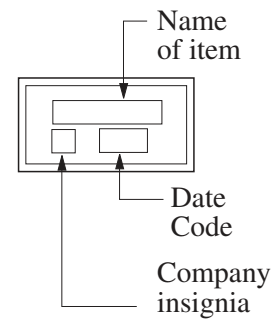
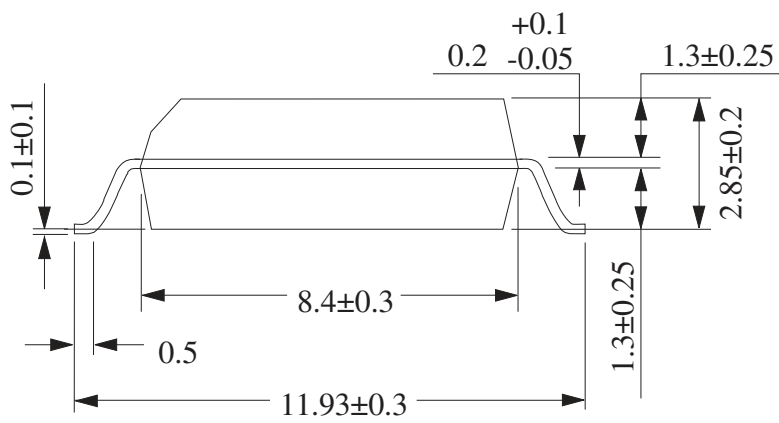
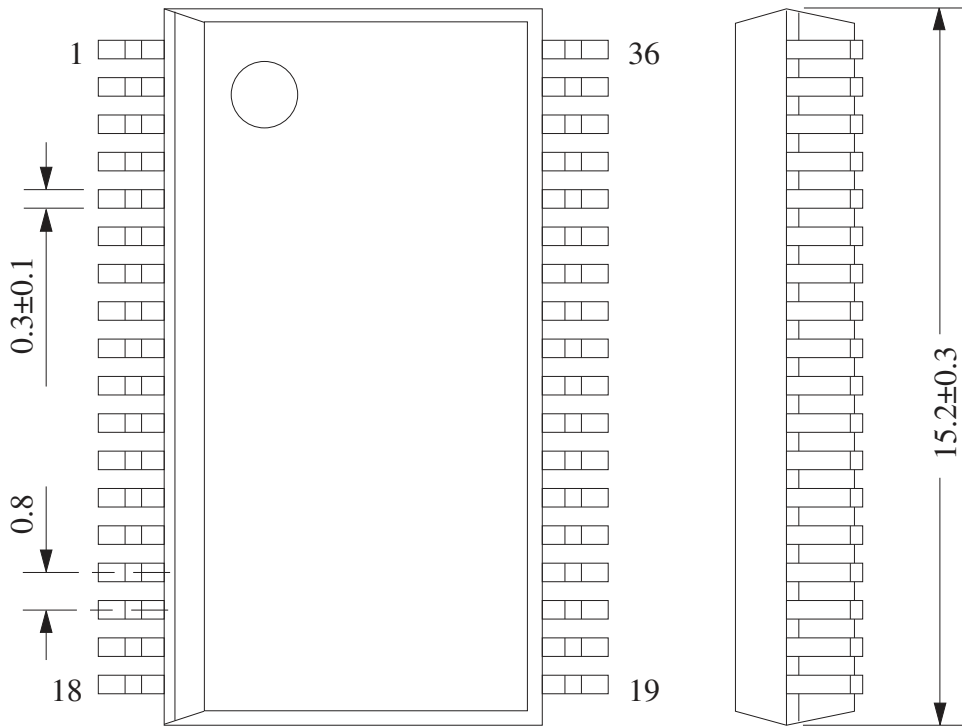

Eff. Date	Eff. Date	Eff. Date	Eff. Date
18 JAN 2002	6 MAR 2002	10 APR 2002	



Prepared		<b>Product Specifications</b> <b>AN15851A</b>	Ref No.	F
Checked			Total Page	21
Approved			Page No.	9

(Structure Description)

Chip surface passivation	SiN,	PSG,	Others ( )	①
Lead frame material	Fe group,	Cu group,	Others ( )	②, ⑥
Inner lead surface process	Ag plating,	Au plating,	Others ( )	②
Outer lead surface process	Solder plating,	Solder dip,	Others ( )	⑥
Chip mounting method	Ag paste,	Au-Si alloy, Solder,	Others ( )	③
Wire bonding method	Ultrasonic heat bonding,		Others ( )	④
Wire material	Au,	Diameter 24 μm	Others ( )	④
Mold material	Epoxy,		Others ( )	⑤
Molding method	Transfer mold,	Multiplunger mold,	Others ( )	⑤

Package USONF-36D

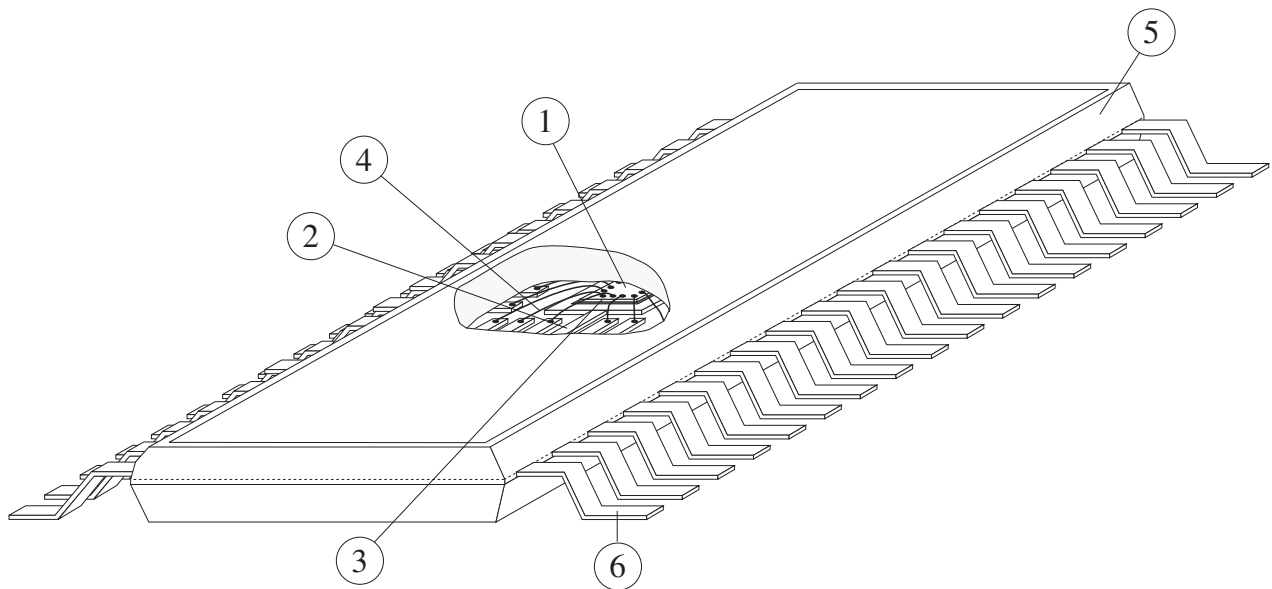

Eff. Date	Eff. Date	Eff. Date	Eff. Date
18 JAN 2002	6 MAR 2002	10 APR 2002	

Prepared		<b>Product Specifications</b> (Technical Data) <b>AN15851A</b>	Ref No.	G-1
Checked			Total Page	21
Approved			Page No.	10

Pin No.	Pin Name	Pin Voltage	Description	Equivalent Circuit
1	G/Y/CV-1	4.5V	<ul style="list-style-type: none"> <li>Video signal input.</li> <li>Can be G, Y or Composite Video signal.</li> <li>Selectively controlled by IIC Bus to convert RGB to YUV.</li> </ul>	
2	B/U/SC-1	4.5V	<ul style="list-style-type: none"> <li>Video signal input.</li> <li>Can be B, U or S-Video Chrominance (SC).</li> <li>Selectively controlled by IIC Bus to convert RGB to YUV.</li> </ul>	
3	R/V/SY-1	4.5V	<ul style="list-style-type: none"> <li>Video signal input.</li> <li>Can be R, V or S-Video Luminance (SY).</li> <li>Selectively controlled by IIC Bus to convert RGB to YUV.</li> </ul>	
4 9 15 20	L1 L2 L3 L4	4.7V	<ul style="list-style-type: none"> <li>Audio signal inputs.</li> </ul>	

Note : Y = Component Video luminance  
 U = Component Video B-Y  
 V = Component Video R-Y

Eff. Date	Eff. Date	Eff. Date	Eff. Date
18 JAN 2002	6 MAR 2002	10 APR 2002	

Prepared		<b>Product Specifications</b> (Technical Data) <b>AN15851A</b>	Ref No.	G-1
Checked			Total Page	21
Approved			Page No.	11

Pin No.	Pin Name	Pin Voltage	Description	Equivalent Circuit
5 10 16 21	R1 R2 R3 R4	4.7V	<ul style="list-style-type: none"> <li>• Audio signal inputs.</li> </ul>	
6 12 17	Y/CV-2 Y/CV-3 Y/CV-4	4.5V	<ul style="list-style-type: none"> <li>• Video signal inputs.</li> <li>• Can be Y or Composite Video.</li> </ul>	

Eff. Date	Eff. Date	Eff. Date	Eff. Date
18 JAN 2002	6 MAR 2002	10 APR 2002	

Prepared		<b>Product Specifications</b> (Technical Data) <b>AN15851A</b>	Ref No.	G-1
Checked			Total Page	21
Approved			Page No.	12

Pin No.	Pin Name	Pin Voltage	Description	Equivalent Circuit
7 13 18	U/SC-2 U/SC-3 U/SC-4	4.5V	<ul style="list-style-type: none"> <li>• Video signal inputs.</li> <li>• Can be U or S-Video Chrominance (SC).</li> </ul>	
8 14 19	V/SY-2 V/SY-3 V/SY-4	4.5V	<ul style="list-style-type: none"> <li>• Video signal inputs.</li> <li>• Can be V or S-Video Luminance (SY).</li> </ul>	

Eff. Date	Eff. Date	Eff. Date	Eff. Date
18 JAN 2002	6 MAR 2002	10 APR 2002	

Prepared		<b>Product Specifications</b> (Technical Data) <b>AN15851A</b>	Ref No.	G-1
Checked			Total Page	21
Approved			Page No.	13

Pin No.	Pin Name	Pin Voltage	Description	Equivalent Circuit
27 33	Y/SY/CV OUT1 Y/SY/CV OUT2	4.5V	<ul style="list-style-type: none"> <li>Video signal output.</li> <li>Can be Y, S -Video Luminance (SY) or Composite Video depend on the input signal.</li> <li>Y/SY/CV OUT1 Video Gain of 4.4dB or 6dB selectively controlled by IIC Bus.</li> <li>Y/SY/CV OUT2 Video Gain of 4.4dB or 6dB selectively controlled by IIC Bus.</li> <li>Y/SY/CV OUT2 has additional feature of converting S- Video inputs to Composite Video selectively controlled by IIC Bus.</li> </ul>	
32	U/SC OUT1	4.5V	<ul style="list-style-type: none"> <li>Video signal output.</li> <li>Can be U or S-Video Chrominance (SC) depend on the input signal.</li> <li>Video Gain of 4.4dB or 6dB selectively controlled by IIC Bus.</li> </ul>	
31	V/SY OUT1	4.5V	<ul style="list-style-type: none"> <li>Video signal output.</li> <li>Can be V or S-Video Luminance (SY) depend on the input.</li> <li>Video Gain of 4.4dB or 6dB selectively controlled by IIC Bus.</li> <li>Video signal Mute selectively controlled by IIC Bus.</li> </ul>	

Eff. Date	Eff. Date	Eff. Date	Eff. Date
18 JAN 2002	6 MAR 2002	10 APR 2002	

Prepared		<b>Product Specifications</b> (Technical Data) <b>AN15851A</b>	Ref No.	G-1
Checked			Total Page	21
Approved			Page No.	14

Pin No.	Pin Name	Pin Voltage	Description	Equivalent Circuit
26	U/SC OUT2	4.5V	<ul style="list-style-type: none"> <li>Video signal output.</li> <li>Can be U or S-Video Chrominance (SC) output signal depend on the input signal.</li> <li>Video Gain of 0dB or 6dB selectively controlled by IIC Bus.</li> </ul>	
25	V/SY OUT2	4.5V	<ul style="list-style-type: none"> <li>Video signal output.</li> <li>Can be V or S-Video Luminance (SY) output signal depend on the input signal.</li> <li>Video Gain of 0dB or 6dB selectively controlled by IIC Bus.</li> </ul>	
23 24 29 30	ROUT2 LOUT2 ROUT1 LOUT1	4.7V	<ul style="list-style-type: none"> <li>Audio signal output.</li> </ul>	

Eff. Date	Eff. Date	Eff. Date	Eff. Date
18 JAN 2002	6 MAR 2002	10 APR 2002	

Prepared		<b>Product Specifications</b> (Technical Data) <b>AN15851A</b>	Ref No.	G-1
Checked			Total Page	21
Approved			Page No.	15

Pin No.	Pin Name	Pin Voltage	Description	Equivalent Circuit
35	SCL	-	● IIC Bus Clock input.	
36	SDA	-	● IIC Bus Data input.	

Eff. Date	Eff. Date	Eff. Date	Eff. Date
18 JAN 2002	6 MAR 2002	10 APR 2002	

Prepared		<b>Product Specifications</b> (Reference Data for Designing) <b>AN15851A</b>	Ref No.	G-2
Checked			Total Page	21
Approved			Page No.	16

## [I<sup>2</sup>C BUS]

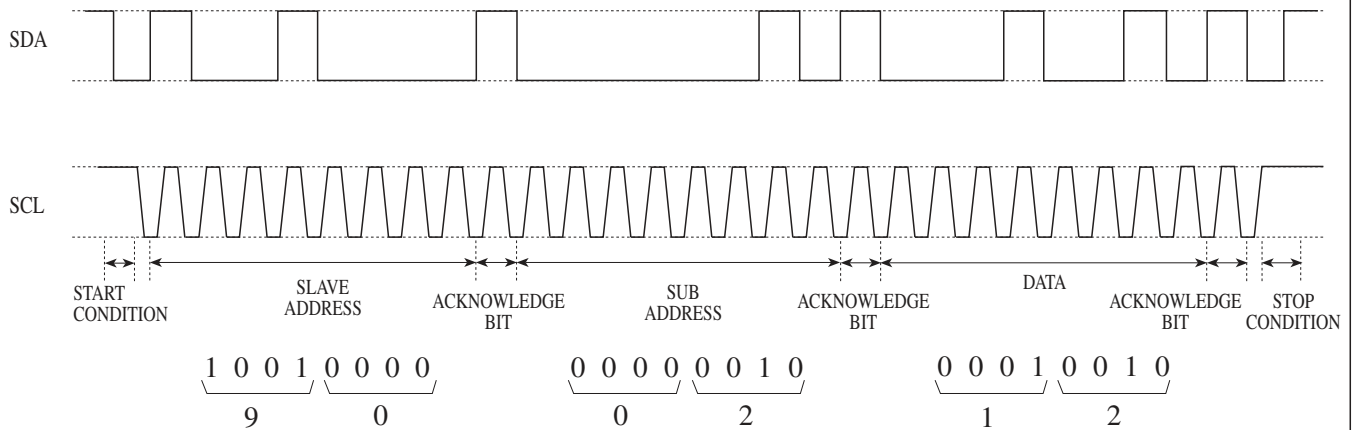

Fig.1 Example of transmission message

For transmission messages, both SCL and SDA are transferred in the form of synchronized serial transmission. SCL is a clock of a specific frequency, and SDA indicates address data for controlling the receiving side and is transferred in parallel, being synchronized with SCL. Data is transferred in principle in 3 octets (bytes), and each one octet (one octet = 8bits) includes one acknowledge bit. Frame structure is described below.

- (a) Start Condition      The receiver becomes possible to receive data when SDA changes from HI to LO while SCL is HI.
- (b) Stop Condition      The receiver halts receiving when SDA changes from LO to HI while SCL is HI.
- (c) Slave Address      This is an address which is determined for each device. If other device address is sent, receiving will be halted.
- (d) Sub Address      This is an address which is determined for each function.
- (e) Data      This is control data.
- (f) Acknowledge Bit      This is a bit by which the master acknowledges that data was successfully received in each octet. Master sends the HI signal and the receiver sends back the LO signal as shown in Figure1 with dotted line, causing the master to acknowledge the reception by the receiver. If the LO signal is not returned, communication will be halted.

Except Start and Stop conditions, SDA does not change while SCL is HI.

Eff. Date	Eff. Date	Eff. Date	Eff. Date	
18 JAN 2002	6 MAR 2002	10 APR 2002		





Prepared		<b>Product Specifications</b> (Reference Data for Designing) <b>AN15851A</b>	Ref No.	G-2
Checked			Total Page	21
Approved			Page No.	18

(4) Sub address byte and data byte format

Sub Address	Data Byte							
	D7	D6	D5	D4	D3	D2	D1	D0
SLAVE	1	0	0	1	0	0	0	0
00	← V/SY OUT1 →		← U/SC OUT1 →		RGB/YUV SEL	← Y/SY/CV OUT1 →		
01	← V/SY OUT2 →		← U/SC OUT2 →		Mute V/SYOUT1	← Y/SY/CV OUT2 →		
02	← Gain Video OUT2 →		← Gain Video OUT1 →		← Audio OUT2 →		← Audio OUT1 →	

SUB-ADDRESS : 00

D2	D1	D0	Y/SY/CV OUT1
0	0	0	G/Y/CV-1 INPUT
0	0	1	Y/CV-2 INPUT
0	1	0	V/SY-2 INPUT
0	1	1	Y/CV-3 INPUT
1	0	0	V/SY-3 INPUT
1	0	1	Y/CV-4 INPUT
1	1	0	V/SY-4 INPUT
1	1	1	G/Y/CV-1 INPUT

SUB-ADDRESS : 00

D3	RGB/YUV SEL
1	Direct
0	RGB→YUV Converter

SUB-ADDRESS : 01

D2	D1	D0	Y/SY/CV OUT2
0	0	0	G/Y/CV-1 INPUT
0	0	1	Y/CV-2 INPUT
0	1	0	V/SY-2 INPUT
0	1	1	Y/CV-3 INPUT
1	0	0	V/SY-3 INPUT
1	0	1	Y/CV-4 INPUT
1	1	0	V/SY-4 INPUT
1	1	1	U/SC OUT2 + V/SY OUT2

SUB-ADDRESS : 01

D3	Mute V/SYOUT1
0	OFF
1	ON

SUB-ADDRESS : 00

D5	D4	U/SC OUT1
0	0	B/U/SC-1 INPUT
0	1	U/SC-2 INPUT
1	0	U/SC-3 INPUT
1	1	U/SC-4 INPUT

SUB-ADDRESS : 00

D7	D6	V/SY OUT1
0	0	R/V/SY-1 INPUT
0	1	V/SY-2 INPUT
1	0	V/SY-3 INPUT
1	1	V/SY-4 INPUT

SUB-ADDRESS : 01

D5	D4	U/SC OUT2
0	0	B/U/SC-1 INPUT
0	1	U/SC-2 INPUT
1	0	U/SC-3 INPUT
1	1	U/SC-4 INPUT

SUB-ADDRESS : 01

D7	D6	V/SY OUT2
0	0	R/V/SY-1 INPUT
0	1	V/SY-2 INPUT
1	0	V/SY-3 INPUT
1	1	V/SY-4 INPUT

Eff. Date	Eff. Date	Eff. Date	Eff. Date	
18 JAN 2002	6 MAR 2002	10 APR 2002		

Prepared		<b>Product Specifications</b> (Reference Data for Designing) <b>AN15851A</b>	Ref No.	G-2
Checked			Total Page	21
Approved			Page No.	19

SUB-ADDRESS : 02

D1	D0	LOUT1/ROUT1
0	0	LIN1, RIN1
0	1	LIN2, RIN2
1	0	LIN3, RIN3
1	1	LIN4, RIN4

SUB-ADDRESS : 02

D3	D2	LOUT2/ROUT2
0	0	LIN1, RIN1
0	1	LIN2, RIN2
1	0	LIN3, RIN3
1	1	LIN4, RIN4

SUB-ADDRESS : 02

Gain Video OUT1		1	0
D4	Y/SY/CV OUT1	6.0dB	4.4dB
D5	U/SC and V/SY OUT1	4.4dB	6.0dB

SUB-ADDRESS : 02

Gain Video OUT2		1	0
D6	Y/SY/CV OUT2	6.0dB	0dB
D7	U/SC and V/SY OUT2	0dB	6.0dB

Eff. Date	Eff. Date	Eff. Date	Eff. Date	
18 JAN 2002	6 MAR 2002	10 APR 2002		

Prepared		<b>Product Specifications</b>  <b>AN15851A</b>	Ref No.	G-3
Checked			Total Page	21
Approved			Page No.	20

### Application Circuit

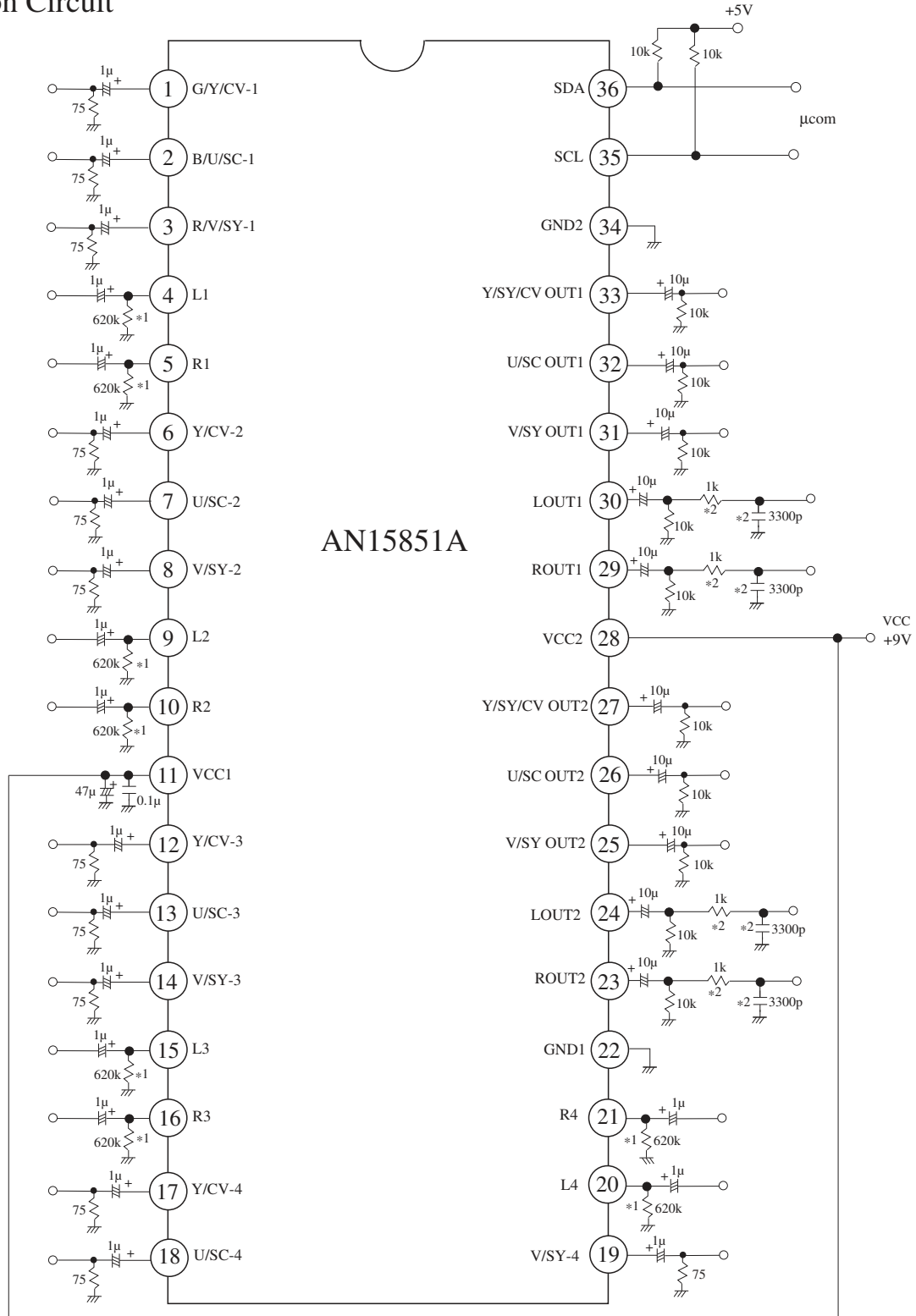

Note : 1) The 620kΩ (\*1) resistors are to improve Audio Input Dynamic Range.  
 2) The 1kΩ resistors (\*2) and 3300pF capacitors (\*2) are for oscillation prevention.

Eff. Date	Eff. Date	Eff. Date	Eff. Date	Eff. Date
18 JAN 2002	6 MAR 2002	10 APR 2002		

Prepared		<b>Product Specifications</b> <b>AN15851A</b>	Ref No.	H
Checked			Total Page	21
Approved			Page No.	21

(Precautions for use)

Make sure that the IC is not reverse mounted or pin shifted. The IC will be damaged under such conditions.

Eff. Date	Eff. Date	Eff. Date	Eff. Date	
18 JAN 2002	6 MAR 2002	10 APR 2002		