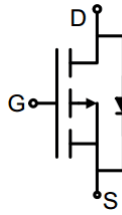
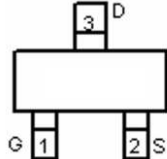
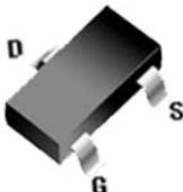

P-Channel Enhancement Mode Power MOSFET

<p>Description</p> <p>The G7P03L uses advanced trench technology to provide excellent $R_{DS(ON)}$, low gate charge. It can be used in a wide variety of applications.</p> <p>General Features</p> <ul style="list-style-type: none"> • V_{DS} -30V • I_D (at $V_{GS} = -10V$) -7A • $R_{DS(ON)}$ (at $V_{GS} = -10V$) < 23mΩ • $R_{DS(ON)}$ (at $V_{GS} = -4.5V$) < 34mΩ • 100% Avalanche Tested • RoHS Compliant <p>Application</p> <ul style="list-style-type: none"> • Power switch • DC/DC converters 		 <p>Schematic diagram</p>  <p>Marking and pin assignment</p>  <p>SOT-23-3L</p>	
Device	Package	Marking	Packaging
G7P03L	SOT-23-3	G7P03	3000pcs/Reel

Absolute Maximum Ratings $T_C = 25^{\circ}C$, unless otherwise noted

Parameter	Symbol	Value	Unit
Drain-Source Voltage	V_{DS}	-30	V
Continuous Drain Current	I_D	-7	A
Pulsed Drain Current (note1)	I_{DM}	-28	A
Gate-Source Voltage	V_{GS}	± 20	V
Power Dissipation	P_D	1.9	W
Operating Junction and Storage Temperature Range	T_J, T_{stg}	-55 To 150	$^{\circ}C$

Thermal Resistance

Parameter	Symbol	Value	Unit
Thermal Resistance, Junction-to-Ambient	R_{thJA}	65.7	$^{\circ}C/W$

Specifications $T_J = 25^\circ\text{C}$, unless otherwise noted						
Parameter	Symbol	Test Conditions	Value			Unit
			Min.	Typ.	Max.	
Static Parameters						
Drain-Source Breakdown Voltage	$V_{(BR)DSS}$	$V_{GS} = 0V, I_D = -250\mu A$	-30	--	--	V
Zero Gate Voltage Drain Current	I_{DSS}	$V_{DS} = -30V, V_{GS} = 0V$	--	--	-1	μA
Gate-Source Leakage	I_{GSS}	$V_{GS} = \pm 20V$	--	--	± 100	nA
Gate-Source Threshold Voltage	$V_{GS(th)}$	$V_{DS} = V_{GS}, I_D = -250\mu A$	-1	-1.5	-2.5	V
Drain-Source On-Resistance	$R_{DS(on)}$	$V_{GS} = -10V, I_D = -3A$	--	19	23	m Ω
		$V_{GS} = -4.5V, I_D = -2A$		27	34	
Dynamic Parameters						
Input Capacitance	C_{iss}	$V_{GS} = 0V,$ $V_{DS} = -15V,$ $f = 1.0\text{MHz}$	--	1500	--	pF
Output Capacitance	C_{oss}		--	178	--	
Reverse Transfer Capacitance	C_{rss}		--	146	--	
Total Gate Charge	Q_g	$V_{DD} = -15V,$ $I_D = -6A,$ $V_{GS} = -10V$	--	29	--	nC
Gate-Source Charge	Q_{gs}		--	5.5	--	
Gate-Drain Charge	Q_{gd}		--	5.5	--	
Turn-on Delay Time	$t_{d(on)}$	$V_{DD} = -15V,$ $I_D = -6A,$ $R_G = 2.5\Omega$	--	10	--	ns
Turn-on Rise Time	t_r		--	44	--	
Turn-off Delay Time	$t_{d(off)}$		--	54	--	
Turn-off Fall Time	t_f		--	59	--	
Drain-Source Body Diode Characteristics						
Continuous Body Diode Current	I_S	$T_C = 25^\circ\text{C}$	--	--	-7	A
Body Diode Voltage	V_{SD}	$T_J = 25^\circ\text{C}, I_{SD} = -3A, V_{GS} = 0V$	--	--	-1.2	V
Reverse Recovery Charge	Q_{rr}	$I_S = -6A, V_{GS} = 0V$ $di/dt = 500A/\mu s$	--	6	--	nc
Reverse Recovery Time	t_{rr}		--	14	--	ns

Notes

1. Repetitive Rating: Pulse width limited by maximum junction temperature
2. Identical low side and high side switch with identical R_G

Gate Charge Test Circuit

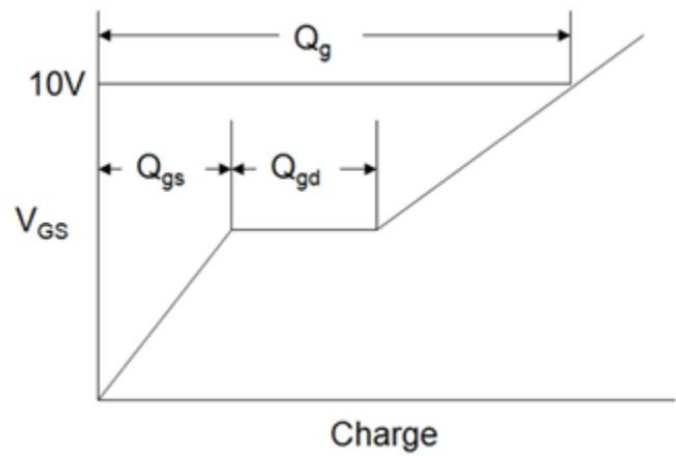
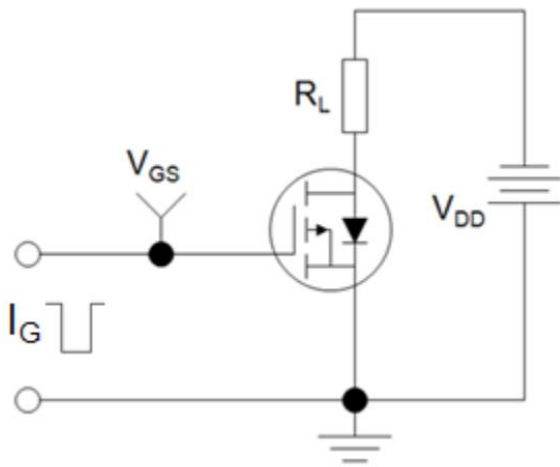

Switch Time Test Circuit

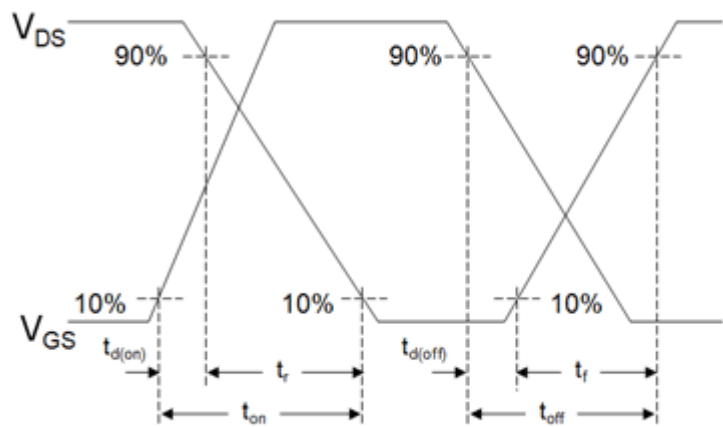
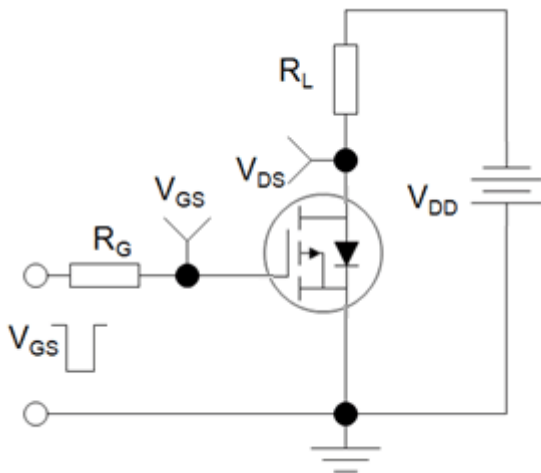

EAS Test Circuit

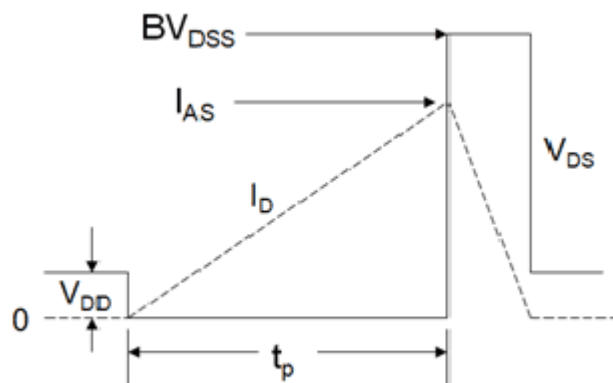
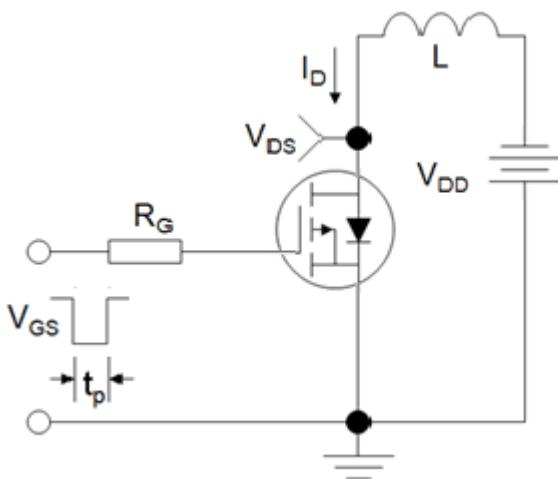

Typical Characteristics $T_J = 25^\circ\text{C}$, unless otherwise noted

Figure 1. Output Characteristics

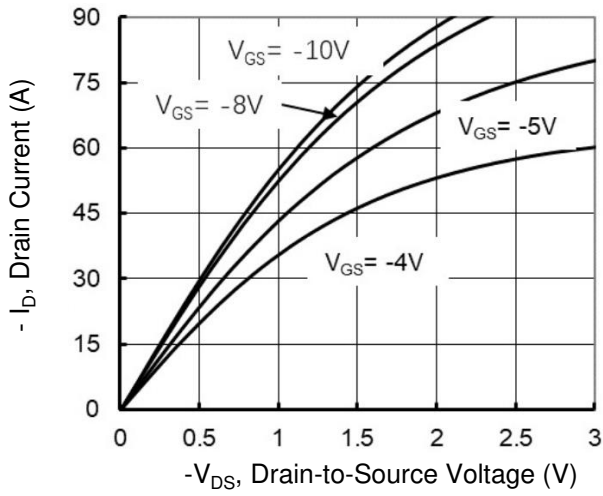

Figure 2. Transfer Characteristics

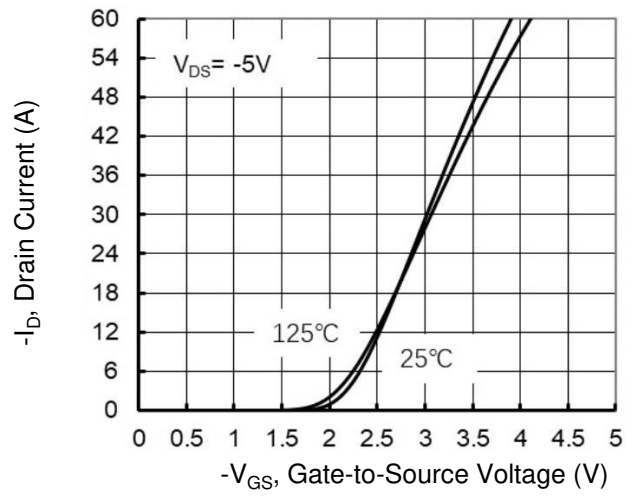

Figure 3. Gate Charge

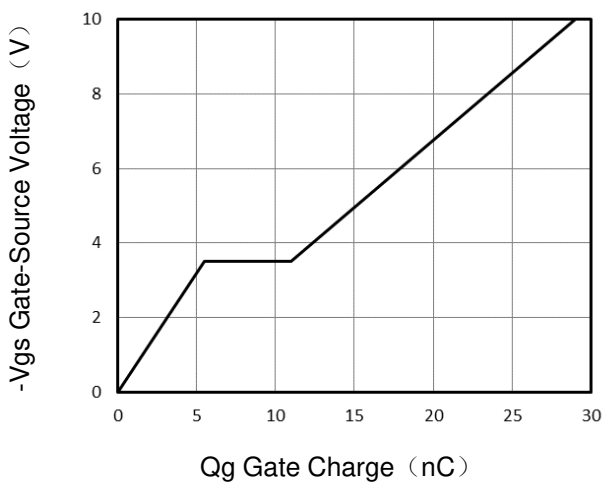

Figure 4. Drain Source On Resistance

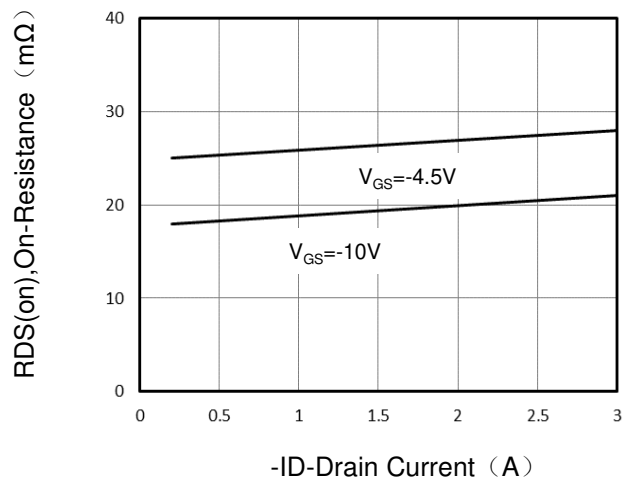

Figure 5. Capacitance

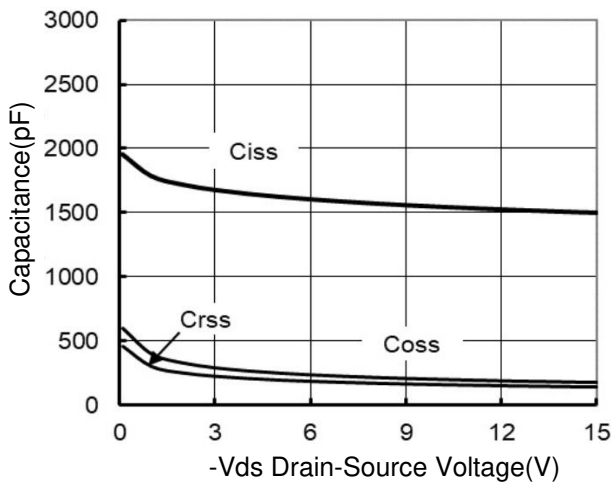
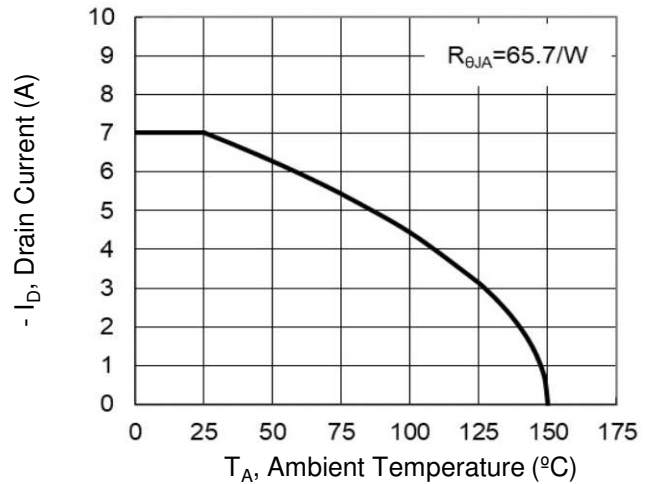

Figure 6. Source-Drain Diode Forward



Typical Characteristics $T_J = 25^\circ\text{C}$, unless otherwise noted

Figure 7. Drain-Source On-Resistance

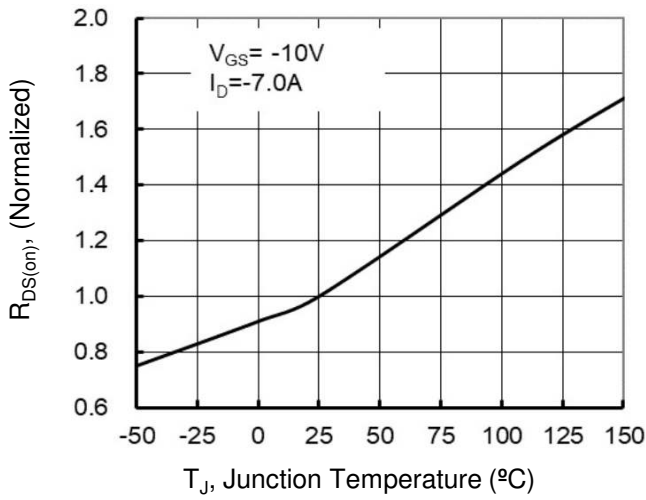

Figure 8. Safe Operation Area

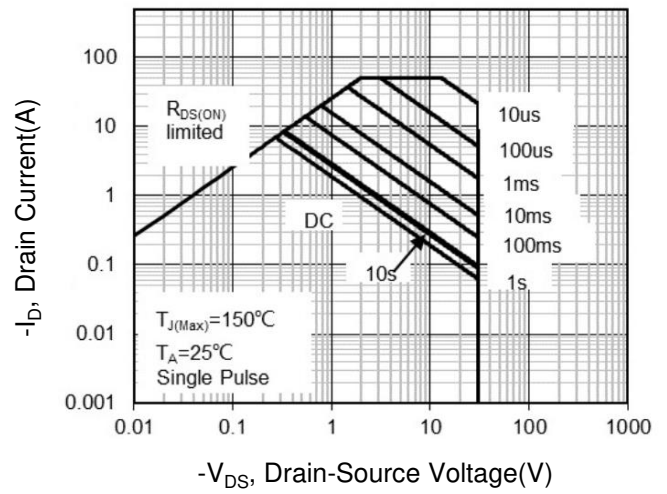
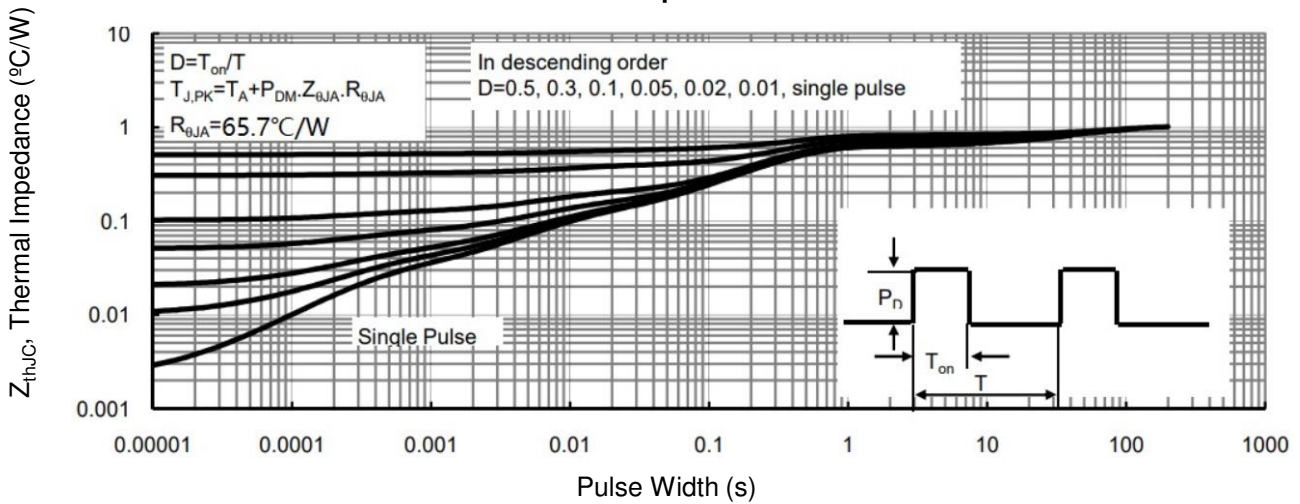
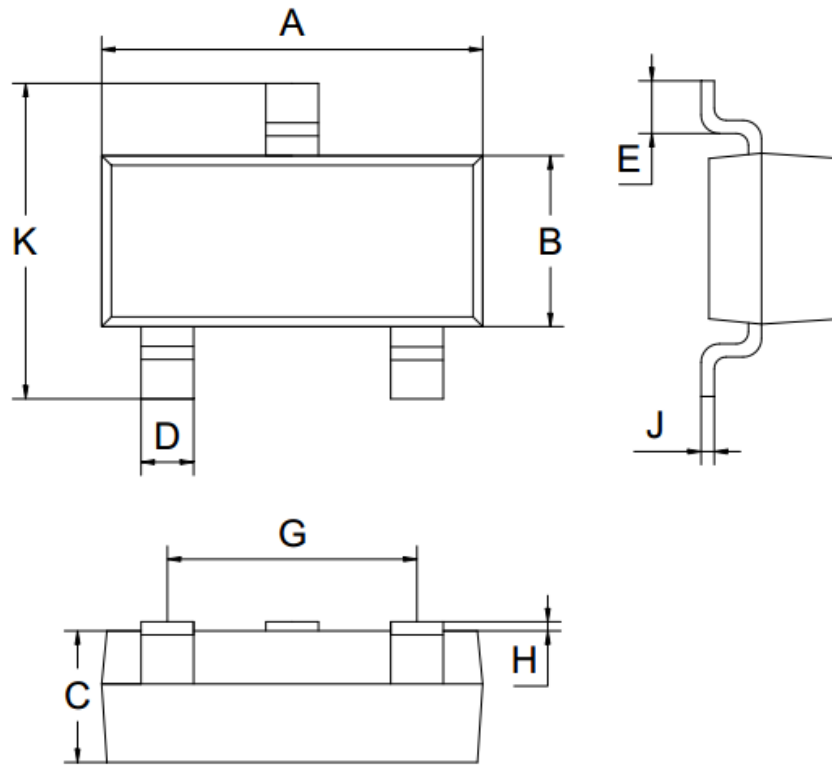

Figure 9. Normalized Maximum Transient Thermal Impedance



SOT-23-3L Package Information



Symbol	Dimensions in Millimeters		
	MIN.	NOM.	MAX.
A	2.80	2.90	3.00
B	1.50	1.60	1.70
C	1.00	1.10	1.20
D	0.30	0.40	0.50
E	0.25	0.40	0.55
G	1.90		
H	0.00	-	0.10
J	0.047	0.127	0.207
K	2.60	2.80	3.00
All Dimensions in mm			