

Driver Characteristics

Parameter	Rating	Units
Input Current	2.5	mA
Switching Speed ($I_F=5\text{mA}$, MOSFET Input Capacitance= 4nF)		
$t_{d(\text{on})}$	3	μs
$t_{d(\text{off1})}$ ($V_{\text{GB}}=2\text{V}$)	365	
$t_{d(\text{off2})}$ ($V_{\text{GB}}=1\text{V}$)	435	

Features

- Integrated 570V to 12.2V regulator circuit for driving high-power, high-voltage MOSFETs eliminates the need for auxiliary power supply
- Capable to source 9.9mA and sink 6mA gate-current to boost external MOSFET turn-on speed
- Enables using higher power MOSFETs
- Only 2.5mA input LED current required
- 3750V_{RMS} Input-to-Output galvanic isolation
- Small 8-pin DIP and Surface Mount Packages

Applications

- Universal 110V_{RMS} - 230V_{RMS} Equipment
- Industrial controls
- Instrumentation
- Automatic Test Equipment (ATE)
- Home & building automation
- HVAC controls
- Medical equipment
- Internet of Things (IoT)



Description

The CPC1596 is an optically isolated, load-biased Gate Driver that requires no additional power supply to bias the external MOSFET gates; in the off-state it regulates the voltage drawn from the load (up to 570V) down to 12.2V for internal use. It is specifically designed for low duty cycle switching applications such as an optically isolated DC relay using a single MOSFET or an AC relay with two MOSFETs.

The CPC1596 accomplishes very fast MOSFET turn-on by supplying charge stored in an external capacitor to the MOSFET gate when input control current is applied to the device's LED. After the MOSFET is turned on, photocurrent from the internal optocoupler keeps the MOSFET active for as long as sufficient input control current is applied assuring very low-frequency operation. When the MOSFET is turned off, the storage capacitor charges from the load voltage via the regulated internal voltage in preparation for the next turn-on.

Provided in a small, 8-pin package and requiring no separate power supply, the CPC1596 provides a flexible design solution that minimizes PCB real estate.

Approvals

- UL Recognized Component: File E76270
- CSA Certified Component: Certificate 70196286

Ordering Information

Part	Description
CPC1596G	8-Pin DIP (50/Tube)
CPC1596GS	8-Pin Surface Mount (50/Tube)
CPC1596GSTR	8-Pin Surface Mount Tape & Reel (1000/Reel)

Figure 1. CPC1596 Load Biased Opto-Gate Driver Application Diagram

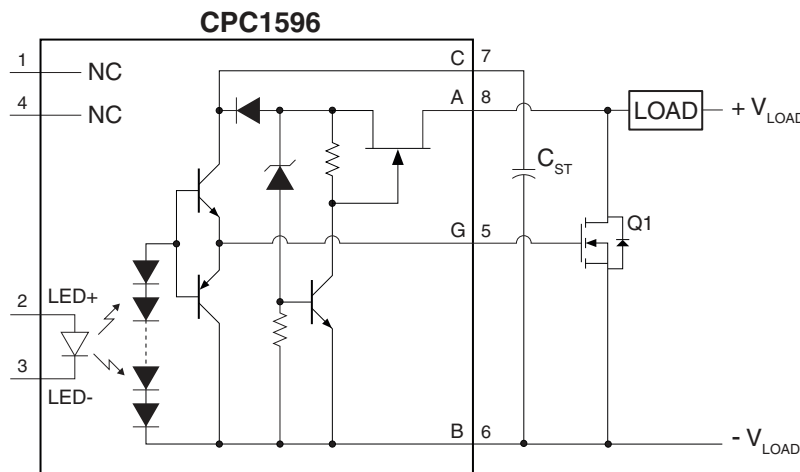

1. Specifications	3
1.1 Package Pinout and Pin Descriptions	3
1.2 Absolute Maximum Ratings	3
1.3 ESD Rating	3
1.4 CSA Approval Ratings	3
1.5 Recommended Operating Conditions	3
1.6 General Conditions	4
1.7 Electrical Specifications	4
1.8 Performance Data*	5
2. Introduction	6
3. Functional Description	6
4. Device Configuration	7
4.1 LED Resistor	7
4.2 Storage Capacitor	7
4.3 Transistor Selection	8
5. CPC1596 Typical AC Switch Application	8
6. Manufacturing Information	9
6.1 Moisture Sensitivity	9
6.2 ESD Sensitivity	9
6.3 Soldering Profile	9
6.4 Board Wash	9
6.5 Mechanical Dimensions	10

1. Specifications

1.1 Package Pinout and Pin Descriptions

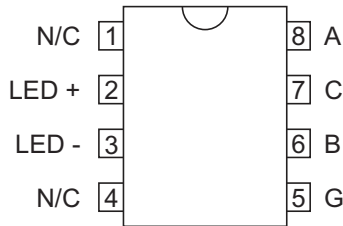

Pin#	Name	Description
1	-	Not internally connected
2	LED +	LED Positive input
3	LED -	LED Negative input
4	-	Not internally connected
5	G	Output, MOSFET Gate Control
6	B	- Load Voltage, Storage Capacitor Negative Connection
7	C	Storage Capacitor Positive Connection
8	A	+ Load Voltage

1.2 Absolute Maximum Ratings

Parameter	Rating	Units
Blocking Voltage (V_{AB})	600	V_P
Reverse Input Voltage	5	V
Input Control Current	20	mA
Peak (10ms)	1	A
Input Power Dissipation	50	mW
Total Package Dissipation	800	mW
Isolation Voltage (Input to Output)	3750	V_{rms}
Operational Temperature	-40 to +110	$^{\circ}C$
Storage Temperature	-40 to +125	$^{\circ}C$

Absolute maximum electrical ratings are at 25 $^{\circ}C$

Absolute maximum ratings are stress ratings. Stresses in excess of these ratings can cause permanent damage to the device. Functional operation of the device at conditions beyond those indicated in the operational sections of this data sheet is not implied.

1.3 ESD Rating

ESD Rating (Human Body Model)
1kV

1.4 CSA Approval Ratings

Parameter	Rating	Units
Basic Insulation	490	V_{rms}
Reinforced Insulation	245	V_{rms}

1.5 Recommended Operating Conditions

Parameter	Symbol	Min	Max	Units
Load Voltage	V_L	15	570	V
Input Control Current	I_F	2.5	10	mA
Operating Temperature	T_A	-40	+110	$^{\circ}C$

1.6 General Conditions

Unless otherwise specified, minimum and maximum values are guaranteed by production testing.

Typical values are characteristic of the device at 25°C and are the result of engineering evaluations. They are provided for informational purposes only and are not part of the manufacturing testing requirements.

Unless otherwise noted, all electrical specifications are listed for $T_A=25^\circ\text{C}$.

1.7 Electrical Specifications

Parameter	Conditions	Symbol	Min	Typ	Max	Units	
Load Side Characteristics							
Gate Voltage	$-40^\circ\text{C} < T_A < 85^\circ\text{C}$	$I_F=2.5\text{mA}$	V_{GB}	5.5	10.6	14.4	V
		$I_F=5\text{mA}$		6.5	10.8	16	
	$-40^\circ\text{C} < T_A < 110^\circ\text{C}$	$I_F=2.5\text{mA}$		4.5	10.6	14.4	
		$I_F=5\text{mA}$		5	10.8	16	
Capacitor Voltage	$12\text{V} < V_{AB} < 570\text{V}$	V_{CB}	10	12.2	16	V	
Gate Drive Capability	$I_F=2.5\text{mA}, V_{GB}=0\text{V}, V_{CB}=12\text{V}$	I_{G_source}	2	9.9	-	mA	
	$I_F=0\text{mA}, V_{GB}=8\text{V}, V_{CB}=8\text{V}$	I_{G_sink}	4	6	13		
	$I_F=0\text{mA}, V_{GB}=4\text{V}, V_{CB}=4\text{V}$		1.5	4	10		
	$I_F=0\text{mA}, V_{GB}=2\text{V}, V_{CB}=2\text{V}$		0.5	2.6	7		
Turn-On Delay	$V_{AB}=48\text{V}, V_{GB}=4\text{V}, C_G=4\text{nF}$	t_{on}	1			μs	
	$I_F=2.5\text{mA}$			4	80		
	$I_F=5\text{mA}$			3	40		
	$I_F=10\text{mA}$			2	20		
Turn-Off Delay	$V_{AB}=48\text{V}, V_{GB}=2\text{V}, C_G=4\text{nF}$	t_{off1}	40			μs	
	$I_F=2.5\text{mA}$			345	500		
	$I_F=5\text{mA}$			365			
	$I_F=10\text{mA}$			385			
	$V_{AB}=48\text{V}, V_{GB}=1\text{V}, C_G=4\text{nF}$	t_{off2}	40			μs	
	$I_F=2.5\text{mA}$			400	600		
	$I_F=5\text{mA}$			435			
	$I_F=10\text{mA}$			450			
Off-State Leakage Current	$V_{AB}=570\text{V}$	I_{AB}	-	14.5	45	μA	
LED Characteristics							
Forward Voltage Drop	$I_F=5\text{mA}$	V_F	1	1.4	1.5	V	
Input Dropout Voltage	$V_F=0.8\text{V}$	V_{GB}	-	0.25	1	V	
Reverse Bias Leakage Current	$V_R=5\text{V}$	I_R	-	-	10	μA	
Common Characteristics							
Input to Output Capacitance	$V_{IO}=0\text{V}, f=1\text{MHz}$	C_{IO}	-	3	-	pF	

1.8 Performance Data*

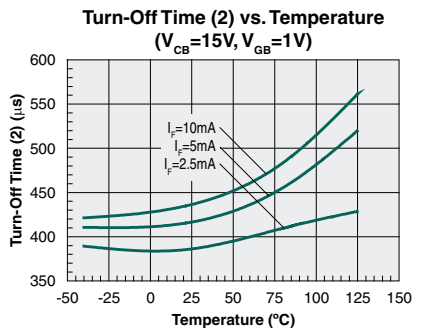
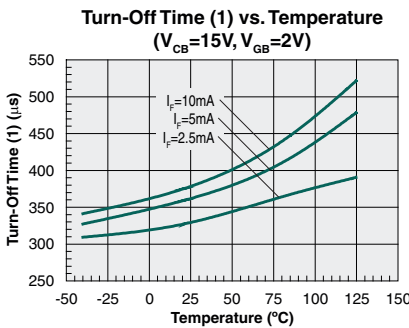
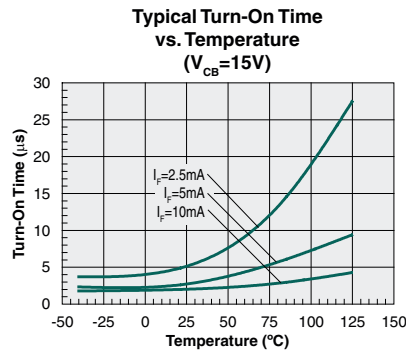
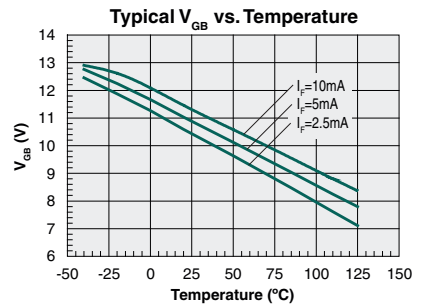
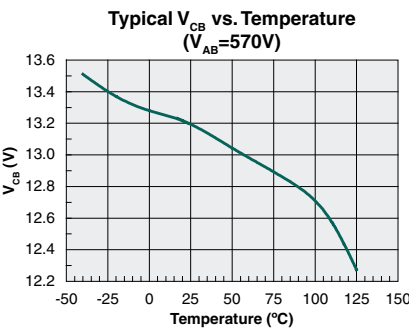
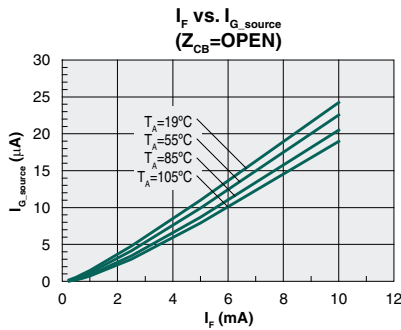
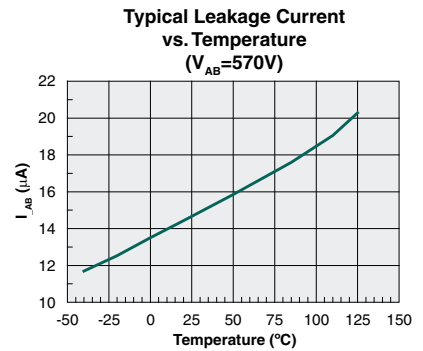
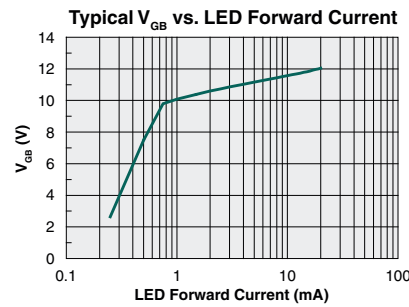
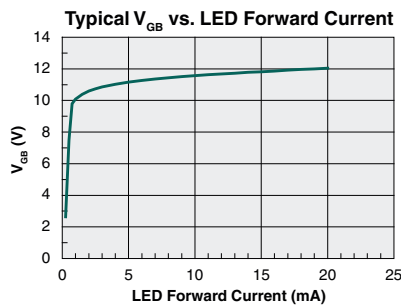
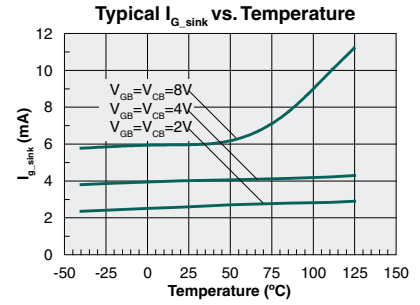
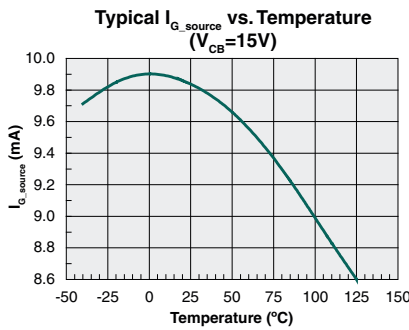
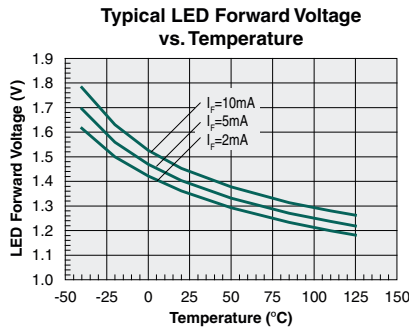

*Unless otherwise noted, data presented in these graphs is typical of device operation at 25°C.

2. Introduction

The CPC1596 is a MOSFET Gate Driver that requires no external power supply. It regulates an input voltage up to 570V to 12.2V for internal use. It is specifically designed for low-duty-cycle switching and low frequency operation of external power MOSFETs with 4nF of gate capacitance.

3. Functional Description

The CPC1596 is used in conjunction with a single MOSFET transistor for remote switching of DC loads (**Figure 2**), or two MOSFET transistors with two diodes for remote low-frequency switching of AC loads (**Figure 3**) where isolated power is unavailable.

The device uses external components to satisfy load switching and over-voltage protection design requirements. Because of this design flexibility, the designer may choose a great number of MOSFETs for use in a wide variety of applications. The designer simply needs to know the MOSFET total gate charge (Q_G), and with this information a capacitor can be chosen. The capacitance of the storage capacitor should be greater than, or equal to, $Q_G/0.5V$.

The CPC1596 has two states of operation:
 (1) sufficient input control current is flowing, the LED is turned on, and the gate current is being applied. The light from the LED is being reflected onto the photovoltaic, which then produces a photocurrent that turns on the NPN bipolar transistor and provides the charge ($I \times t = Q$), or the gate current that is being

applied to turn on the MOSFET. (2) Sufficient input control current is not flowing, the LED is off, and gate current to the external MOSFET is not flowing. When the LED is off the photovoltaic discharges causing the PNP bipolar transistor to conduct, providing a discharge path for the charge stored in the external MOSFET's gate.

When V_{LOAD} is first applied, the external storage capacitor begins to charge. The charge passes through a bootstrap diode that prevents the stored charge from discharging whenever the power MOSFET is turned-on. The N-channel, depletion-mode DMOS regulates the voltage across the external storage capacitor to between 10V and 16V. With sufficient input control current applied, charge from the storage capacitor is transferred through the NPN bipolar transistor along with the charge from the photovoltaic to the MOSFET gate to accomplish a rapid turn-on. After the capacitor has discharged and the MOSFET has turned on, photocurrent from the photovoltaic continues to flow into the gate keeping the MOSFET turned on.

When the input control current is removed, current out of the photovoltaic to the MOSFET gate ceases and the photovoltaic discharges. This causes the PNP bipolar transistor to activate, discharging the MOSFET gate. The MOSFET is now off. At this point the capacitor begins to recharge for the next turn on cycle.

The circuit below does not include over-voltage protection.

Figure 2. CPC1596 DC Application Circuit

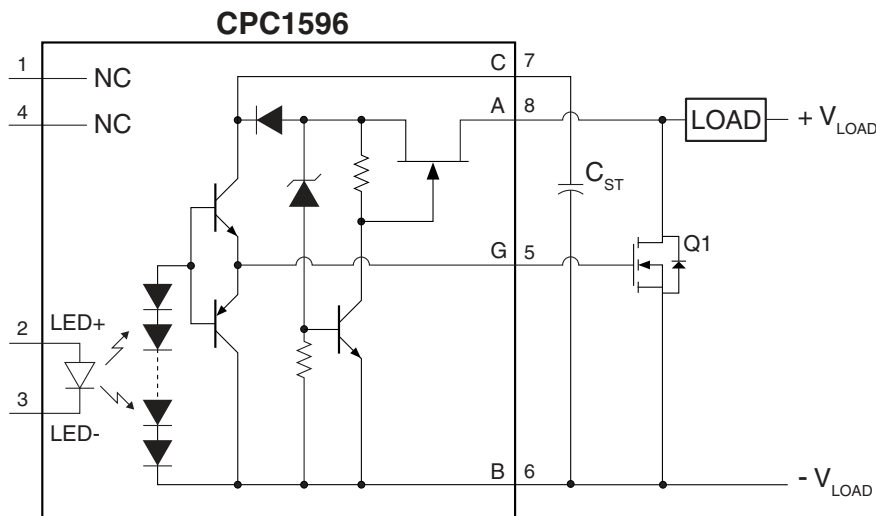

4. Device Configuration

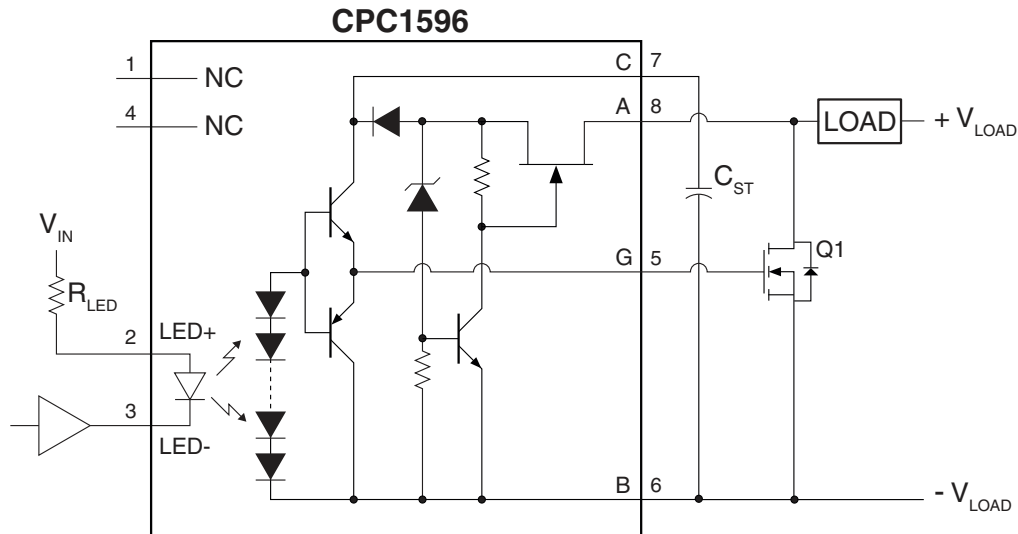

4.1 LED Resistor

The input resistor is required to configure LED current to a compliant value as specified in “**Recommended Operating Conditions**” on page 3.

The general equation used to calculate the resistor value is:

$$R_{LED} = \frac{V_{IN} - (V_F + V_{OL})}{I_F}$$

- I_F = Input Control Current
- V_{OL} = Low-level output of the drive circuit. This parameter is provided in the manufacturer’s data sheet.
- V_{IN} = Input Power Source
- V_F = Forward Voltage Drop of LED
- R_{LED} = Input Resistor

When calculating the resistor value, the designer should take into consideration power-supply variations, temperature variations, LED forward voltage drop over the end product’s operational temperature range, and the resistor’s tolerance and temperature stability rating.

When the LED resistor value is selected by the above formula, the R_{LED} power dissipation, P_D , can be obtained from the following equation:

$$P_D = I_F^2 \cdot R_{LED}$$

With power dissipation calculated, it is now possible to select the appropriate resistor size to be used in the application circuit.

4.2 Storage Capacitor

The storage capacitor (C_{ST}) enables the gate driver to turn on a power MOSFET faster by delivering a reservoir of charge to the gate. Selection of the storage capacitor is given by the following equation:

$$C_{ST} \geq Q_G / 0.5V$$

This equation shows that the storage capacitor needs to deliver enough charge to the gate while only dropping 0.5V. The CPC1596 delivers 32nC of charge at rated operating speed, but will operate with loads greater than 4nF with slower turn-on and turn-off times.

The CPC1596 utilizes an internal FET to regulate the voltage applied to the storage capacitor. The voltage applied to the storage capacitor will be between 10V and 16V.

4.3 Transistor Selection

The CPC1596 charges and discharges an external MOSFET transistor. The selection of the MOSFET is determined by the end product's specific load power switching requirements and the drive capabilities of the gate driver. The CPC1596 output voltage and load current switching current capabilities are listed in the specification, but, as mentioned earlier, there must be little or no gate leakage.

Another parameter that plays a significant role in the selection of the transistor is the gate drive voltage available from the CPC1596. The user must select a transistor that will maintain the load current over the required operating conditions, given the V_{GB} in the CPC1596 specifications.

5. CPC1596 Typical AC Switch Application

The CPC1596 can be used in other configurations. Another configuration is shown in **Figure 3**, which is called an AC Switch. This simply means that either terminal can be positive or negative. The AC Switch configuration requires a second MOSFET (Q2) and two rectifying diodes (D1 and D2).

The design considerations for this configuration are the same as for the previous example. Diodes D1 and D2 must have voltage ratings greater than the load voltage.

Figure 3. Application Circuit for Using the CPC1596 as an AC Switch

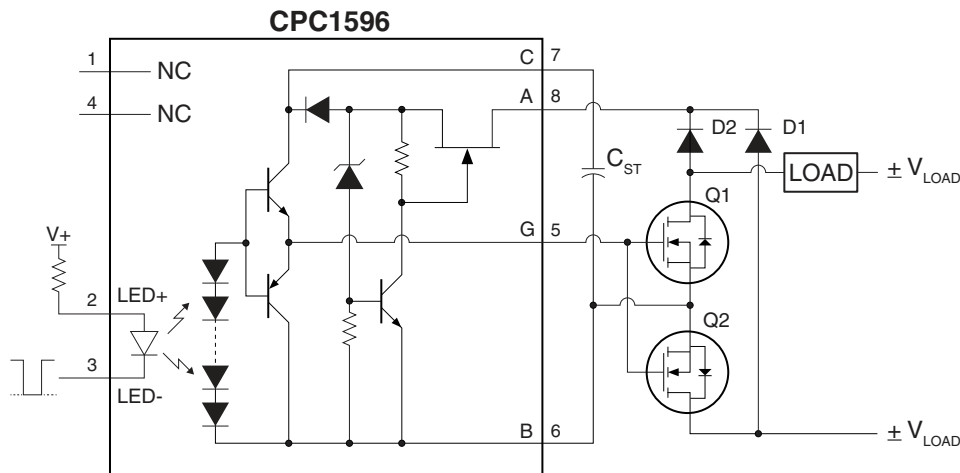

6. Manufacturing Information

6.1 Moisture Sensitivity



All plastic encapsulated semiconductor packages are susceptible to moisture ingress. IXYS Integrated Circuits classifies its plastic encapsulated devices for moisture sensitivity according to the latest version of the joint industry standard, **IPC/JEDEC J-STD-020**, in force at the time of product evaluation. We test all of our products to the maximum conditions set forth in the standard, and guarantee proper operation of our devices when handled according to the limitations and information in that standard as well as to any limitations set forth in the information or standards referenced below.

Failure to adhere to the warnings or limitations as established by the listed specifications could result in reduced product performance, reduction of operable life, and/or reduction of overall reliability.

This product carries a **Moisture Sensitivity Level (MSL)** classification as shown below, and should be handled according to the requirements of the latest version of the joint industry standard **IPC/JEDEC J-STD-033**.

Device	Moisture Sensitivity Level (MSL) Classification
CPC1596GS	MSL 1

6.2 ESD Sensitivity



This product is **ESD Sensitive**, and should be handled according to the industry standard **JESD-625**.

6.3 Soldering Profile

Provided in the table below is the **IPC/JEDEC J-STD-020** Classification Temperature (T_C) and the maximum dwell time the body temperature of these surface mount devices may be ($T_C - 5$)°C or greater. The Classification Temperature sets the Maximum Body Temperature allowed for these devices during reflow soldering processes.

Device	Classification Temperature (T_C)	Dwell Time (t_p)	Max Reflow Cycles
CPC1596GS	250°C	30 seconds	3

For through-hole devices, the maximum and minimum peak solder temperature limits (T_p) and the device maximum total dwell time through all solder waves is provided in the table below. Dwell time is the interval the device pins are at or above the minimum peak solder temperature. Body temperature of the device must not exceed the limit given in the table below at any time during the soldering process.

Device	Solder Temperature (T_p)		Body Temperature	Dwell Time	Wave Cycles
	Minimum	Maximum			
CPC1596G	235°C	260°C	250°C	10 seconds*	1

*Total cumulative duration of all waves.

6.4 Board Wash

IXYS Integrated Circuits recommends the use of no-clean flux formulations. Board washing to reduce or remove flux residue following the solder reflow process is acceptable provided proper precautions are taken to prevent damage to the device. These precautions include but are not limited to: using a low pressure wash and providing a follow up bake cycle sufficient to remove any moisture trapped within the device due to the washing process. Due to the variability of the wash parameters used to clean the board, determination of the bake temperature and duration necessary to remove the moisture trapped within the package is the responsibility of the user (assembler). Cleaning or drying methods that employ ultrasonic energy may damage the device and should not be used. Additionally, the device must not be exposed to halide flux or solvents.



6.5 Mechanical Dimensions

6.5.1 CPC1596G 8-Pin DIP Package

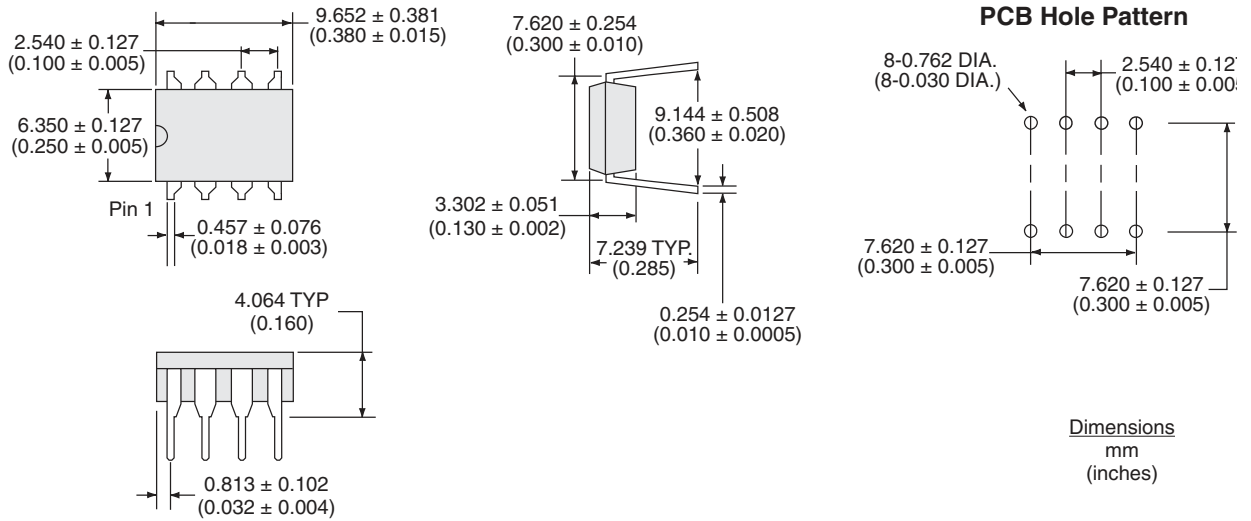

6.5.2 CPC1596GS 8-Pin Surface Mount Package

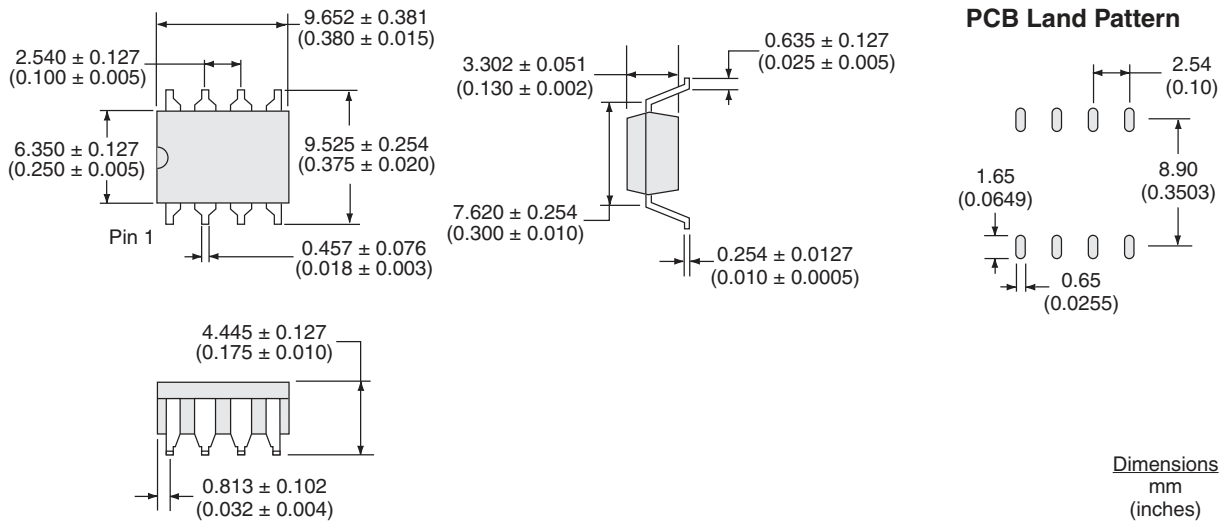

6.5.3 CPC1596GSTR Surface Mount Package Tape & Reel

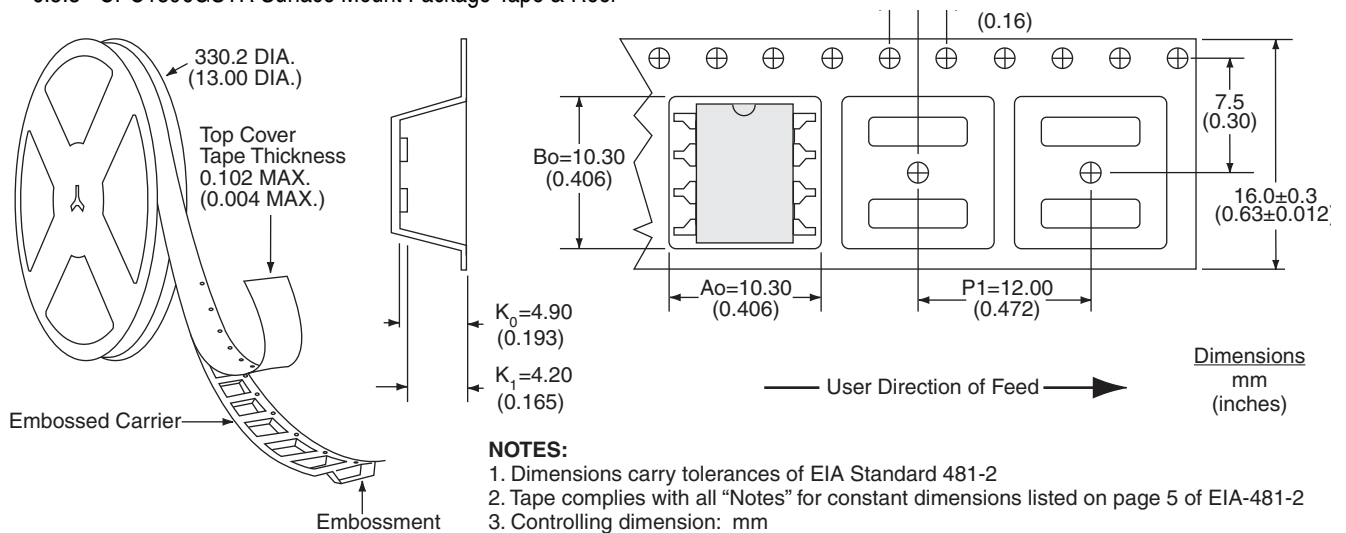

For additional information please visit our website at: <https://www.ixysic.com>



Disclaimer Notice - Information furnished is believed to be accurate and reliable. However, users should independently evaluate the suitability of and test each product selected for their own applications. Littelfuse products are not designed for, and may not be used in, all applications. Read complete Disclaimer Notice at <https://www.littelfuse.com/disclaimer-electronics>.

Specification: DS-CPC1596-R03
 ©Copyright 2022, Littelfuse, Inc.
 All rights reserved. Printed in USA.
 5/3/2022